



FlowTracker2[®]

USER'S MANUAL 1.6
SOFTWARE VERSION 1.6
FIRMWARE VERSION 1.3



Copyright 2019 by Xylem Inc. All rights reserved. This document may not, in whole or in part, be copied, photocopied, reproduced, translated, or reduced to any electronic medium or Machine-readable form without prior consent in writing from Xylem. Every effort has been made to ensure the accuracy of this manual. However, Xylem makes no warranties with respect to this documentation and disclaims any implied warranties of merchantability and fitness for a particular purpose. Xylem shall not be liable for any errors or for incidental or consequential damages in connection with the furnishing, performance, or use of this manual or the examples herein. The information in this document is subject to change without notice.



a xylem brand

9940 Summers Ridge Rd
San Diego, CA 92121
+1.858.546.8327
inquiry@sontek.com
sontek.com

SonTek – a Xylem brand

9940 Summers Ridge Rd, San Diego, CA 92121-3091 USA

Telephone +1 (858) 546-8327 • Fax +1 (858) 546-8150

E-mail: inquiry@sontek.com • Internet: www.sontek.com

User's Manual 1.6
Software Version 1.6
Firmware Version 1.30

Copyright 2018 by Xylem Inc. All rights reserved. This document may not, in whole or in part, be copied, photocopied, reproduced, translated, or reduced to any electronic medium or Machine-readable form without prior consent in writing from Xylem. Every effort has been made to ensure the accuracy of this manual. However, Xylem makes no warranties with respect to this documentation and disclaims any implied warranties of merchantability and fitness for a particular purpose. Xylem shall not be liable for any errors or for incidental or consequential damages in connection with the furnishing, performance, or use of this manual or the examples herein. The information in this document is subject to change without notice.

Release Notice

45-0120 Rev C

This is the October 2018 release of the FlowTracker2 User’s Manual. During the creation of this manual, the following were the latest versions of firmware/software. As such, if you are using different firmware/software versions, not all aspects of this manual may apply.

- FlowTracker2 firmware version 1.30
- FlowTracker2 software version 1.6

Trademarks

The terms FlowTracker2 are registered trademarks of Xylem Inc. All rights are reserved. All other brand names are trademarks of their respective holders.

Warranty, Terms, and Conditions

Thank you for purchasing the FlowTracker2. The instrument was thoroughly tested at the factory and found to be in excellent working condition. If the shipping crate appears damaged, or if the system is not operating properly, please contact us immediately.

The system you have purchased is covered under a two year limited warranty that extends to all parts and labor for any malfunction due to workmanship or errors in the manufacturing process. The warranty does not cover shortcomings that are due to the design, nor does it cover any form of incidental damage as a result of errors in the measurements.

If your system is not functioning properly, first try to identify the source of the problem. If additional support is required, we encourage you to contact us immediately, and we will work to resolve the problem as quickly as possible.

If the system needs to be returned to the factory, please contact technical support to obtain a Service Request (SR) number. We reserve the right to refuse shipments without SR numbers. We require the system to be shipped back in the original shipping container using the original packing material with all delivery costs covered by the customer (including all taxes and duties). If the system is returned without appropriate packing, the customer will be required to cover the cost of a new packaging crate and material.

Contact Information

Any questions, concerns, or suggestions can be directed to SonTek by telephone, fax, or email. Business hours are 8:00 a.m. to 5:00 p.m., Pacific Standard Time, Monday through Friday.

- Phone : +1 (858) 546-8327
- Fax : +1 (858) 546-8150
- Email : inquiry@sontek.com (General information)
sales@sontek.com (Sales information)
support@sontek.com (Support information)
- Web : <http://www.sontek.com>

See our web site for information concerning new products and software/firmware upgrades.

FCC INFORMATION

This device complies with part 15 of the FCC Rules. Operation is subject to the following two conditions: (1) This device may not cause harmful interference, and (2) this device must accept any interference received, including interference that may cause undesired operation.

The FlowTracker2 FCC license number can be found in two locations: (1) on the shipping box label and (2) engraved on the back of the FlowTracker2. Examples of the shipping box label and engraving are shown below.

Table of Contents

- List of Tables 14**
- List of Equations 16**
- Section 1. Quick Overview 17**
 - 1.1. System Components..... 17
 - 1.2. Definitions and Terminology..... 19
- Section 2. System Operation..... 21**
 - 2.1. On/Off Switch 21
 - 2.2. Keypad 21
 - 2.3. Keypad Filter 23
 - 2.4. Screen Layout 24
 - 2.5. Main Menu 24
 - 2.5.1 Device Configuration Menu (Main Menu) 25
 - 2.5.2 Utilities (Main Menu)..... 26
 - 2.5.3 Communication (Main Menu) 26
 - 2.5.4 System Information (Main Menu) 26
 - 2.5.5 Measurement (Main Menu) 27
 - 2.5.6 Data Files (Main Menu) 28
- Section 3. Device Configuration 30**
 - 3.1. User Interface..... 30
 - 3.1.1 Language 30
 - 3.1.2 Use Beeper 31
 - 3.1.3 Color Scheme..... 31
 - 3.1.4 Font Size 32
 - 3.2. Application Settings..... 32
 - 3.2.1 Units 33
 - 3.2.2 Wading Rod..... 33
 - 3.2.3 File Naming 34
 - 3.2.4 Folder Naming..... 35
 - 3.2.5 GPS Station Tagging 36
 - 3.2.6 Use Pressure Sensor (Pressure Sensor)..... 38
 - 3.2.7 Probe Offset From WR Bottom (Pressure Sensor)..... 38
 - 3.2.8 Air Pressure Cal. Period (min) (Pressure Sensor) 38
 - 3.3. Configuration Templates 40
 - 3.3.1 Template Options 40
 - 3.3.2 Managing Templates..... 40
 - 3.3.2.1 Accessing Templates..... 40
 - 3.3.2.2 New Template 41

- 3.3.2.3 Selecting Template 41
- 3.4. Template Functions..... 42
 - 3.4.1 File Properties 42
 - 3.4.2 Data Collection Settings 43
 - 3.4.2.1 Averaging Time 44
 - 3.4.2.2 Salinity 44
 - 3.4.2.3 Temperature..... 45
 - 3.4.2.4 Sound Speed 45
 - 3.4.2.5 Mounting Correction..... 46
 - 3.4.3 Quality Control Settings 46
 - 3.4.3.1 SNR Threshold..... 47
 - 3.4.3.2 Std Error Threshold..... 48
 - 3.4.3.3 Spike Threshold 48
 - 3.4.3.4 Velocity Angle for Warning..... 48
 - 3.4.3.5 Tilt Angle Warning..... 49
 - 3.4.4 Discharge Settings 49
 - 3.4.4.1 Discharge Equation..... 50
 - 3.4.4.2 Discharge Uncertainty..... 50
 - 3.4.4.3 Discharge Reference 51
 - 3.4.4.4 Max Station Q for Warning (%) 51
 - 3.4.4.5 Max Depth Change for Warning (%)..... 51
 - 3.4.4.6 Max Spacing Change for Warning (%) 52
 - 3.4.4.7 0.6 Method Depth..... 52
 - 3.4.5 Displayed Velocity Methods 52
- Section 4. Utilities 54**
 - 4.1. System Clock 54
 - 4.1.1 Manual Change 54
 - 4.1.2 Sync with GPS Time 55
 - 4.2. Recorder 56
 - 4.2.1 Manage Recorder..... 56
 - 4.2.2 Erase Recorder 57
 - 4.3. Battery Data 58
 - 4.3.1 Battery Type 58
 - 4.3.2 Battery Voltage..... 59
 - 4.3.3 Percentage Full 59
 - 4.4. Raw Data Display..... 59
 - 4.4.1 Velocity Raw Data 60
 - 4.4.2 SNR Raw Data 62
 - 4.4.3 Temperature Raw Data 62
 - 4.4.4 Tilt Raw Data..... 63
 - 4.4.5 Battery Indicator 63
 - 4.4.6 Pressure (Pressure Sensor)..... 63
 - 4.5. Automated Beam Check 64
 - 4.6. Beam Check..... 65

4.7.	GPS Data.....	65
4.8.	Pressure Sensor (Pressure Sensor)	66
4.9.	System Maintenance.....	67
4.9.1	Force Probe Upgrade.....	67
Section 5. Data Collection Modes		69
5.1.	Discharge Mode.....	69
5.1.1	Measurement Technique	69
5.1.2	Discharge Calculation Methods	70
5.1.2.1	Mid-Section Equation.....	70
5.1.2.2	Mean-Section Equation.....	72
5.1.2.3	Japanese Equation	73
5.1.3	Determining Mean Station Velocity.....	75
5.1.3.1	Method None.....	77
5.1.3.2	Vertical Velocity Curve.....	77
5.1.3.3	Correction Factor	78
5.1.4	Discharge Uncertainty Calculation	79
5.1.5	Under Ice Measurements.....	80
5.1.6	Weighted Gauge Height.....	81
5.2.	General Mode	82
5.2.1	Measurement Technique	82
5.2.2	Determining Mean Velocity	82
Section 6. Quality Control		83
6.1.	Quality Control Parameters.....	83
6.1.1	Signal to Noise Ratio (SNR).....	84
6.1.2	Velocity Standard Error	87
6.1.3	Boundary Interference.....	88
6.1.4	Velocity Spike Filter.....	90
6.1.5	Velocity Angle.....	91
6.1.6	Tilt Angle	93
6.1.7	Station Percent Discharge	93
6.1.8	Station Water Depth.....	94
6.1.9	Station Location.....	95
6.1.10	Velocity Profile 0.2 \ 0.8	96
6.2.	Quality Control Warning Messages.....	96
6.2.1	Types of Warning Messages.....	96
6.2.2	Timing of Warning Messages.....	98
6.3.	Beam Check.....	98
6.3.1	Beam Check Overview.....	99
6.3.2	Beam Check Features	100
6.3.3	Beam Check Operation.....	101
6.3.4	Diagnosing Measurements with Beam Check	101
6.3.4.1	Low Scattering Strength.....	101
6.3.4.2	Strong Scattering Strength.....	101
6.3.4.3	Boundary Detected within Beam Check	102

6.3.4.4	Boundary in Sampling Volume.....	103
6.4.	Automated Beam Check	104
Section 7. Measurement Process		107
7.1.	Office Procedures	107
7.1.1	Equipment List.....	107
7.1.2	Hardware Inspection	108
7.1.3	Office Diagnostic	108
7.2.	Measurement Site Information	110
7.3.	Pre Measurement Diagnostics	111
7.4.	Measurement Procedure.....	112
7.5.	Post Measurement Requirements.....	113
7.5.1	Review of Measurement Site Information	114
7.5.2	Review Measurement Summary	114
7.5.3	Data Management.....	115
7.5.4	Storage.....	115
Section 8. Discharge Measurement.....		117
8.1.	Create Measurement	117
8.1.1	Measurement	117
8.1.2	New File Type	117
8.1.3	New File Template	118
8.1.4	New Data File.....	118
8.2.	Automated Beam Check	119
8.2.1	Start Automated Beam Check.....	120
8.2.2	Evaluate Beam Check Results.....	120
8.3.	Data Collection.....	122
8.3.1	Data Collection Window	122
8.3.1.1	Add Station.....	123
8.3.1.2	Delete Station.....	123
8.3.1.3	Edit Station.....	124
8.3.2	Station Types	126
8.3.2.1	Bank (left or right).....	127
8.3.2.2	Island Edge	127
8.3.2.3	Open Water.....	128
8.3.2.4	Ice.....	130
8.3.3	Station Measurement (Wading Rod).....	131
8.3.3.1	Station Parameters	131
8.3.3.2	Point Velocity Measurement	131
8.3.3.3	Review Point Measurement	134
8.3.3.4	Review Station Measurement.....	135
8.3.4	Station Measurement (Pressure Sensor).....	137
8.3.4.1	Station Parameters	138
8.3.4.2	Point Velocity Measurement	138
8.3.4.3	Review Point Measurement	142

8.3.4.4	Review Station Measurement	143
8.3.5	Data Collection Menu	145
8.3.5.1	Settings	146
8.3.5.2	Supplemental Data.....	146
8.3.5.3	Discharge Summary.....	147
8.3.5.4	Station Summary.....	148
8.3.5.5	Automated Beam Check	149
8.3.5.6	PS Calibration (Pressure Sensor).....	150
8.3.5.7	Complete Measurement.....	150
8.3.5.8	Discard Measurement	151
8.3.5.9	Go to Home Screen	152
8.4.	Measurement Summary	152
Section 9. General Measurement.....		154
9.1.	Create Measurement	154
9.1.1	Measurement	154
9.1.2	New File Type	154
9.1.3	New File Template	155
9.1.4	New Data File.....	155
9.2.	Automated Beam Check	156
9.2.1	Start Automated Beam Check.....	157
9.2.2	Evaluate Beam Check Results.....	157
9.3.	Data Collection.....	159
9.3.1	Data Collection Window	159
9.3.1.1	Add Station.....	160
9.3.1.2	Delete Station.....	161
9.3.2	Station Measurement (Wading Rod).....	161
9.3.2.1	Point Velocity Measurement	162
9.3.2.2	Review Point Measurement	164
9.3.2.3	Review Station Measurement	165
9.3.3	Station Measurement (Pressure Sensor).....	166
9.3.3.1	Point Velocity Measurement	166
9.3.3.2	Review Point Measurement	169
9.3.3.3	Review Station Measurement	171
9.3.4	Data Collection Menu.....	172
9.3.4.1	Settings	173
9.3.4.2	Velocity Summary	173
9.3.4.3	Automated Beam Check	174
9.3.4.4	PS Calibration (Pressure Sensor).....	174
9.3.4.5	Complete Measurement.....	175
9.3.4.6	Discard Measurement	176
9.3.4.7	Go to Home Screen	177
9.4.	Measurement Summary	177
Section 10. FlowTracker2 Hardware.....		179
10.1.	ADV Probe	179

10.2.	Handheld	180
10.3.	Cables and Connectors	181
10.4.	Certifications	181
10.5.	PC System Requirements.....	182
Section 11. Operational Considerations		183
11.1.	Software Upgrade	183
11.1.1	Upgrading Handheld Software	183
11.1.2	Upgrading ADV Firmware	185
11.2.	Mounting and Installation	185
11.2.1	FlowTracker2 Handheld	185
11.2.2	Handheld Mounting Bracket.....	185
11.2.3	Probe Mounting Bracket.....	186
11.3.	Routine Maintenance	187
11.3.1	Battery Power Supply.....	187
11.3.2	Cleaning Instrument	187
11.3.2.1	Handheld	187
11.3.2.2	Transducers	188
11.3.3	Cable Maintenance	188
11.3.4	O-rings.....	189
11.3.4.1	Housing	189
11.3.4.2	Battery Cap	189
11.3.5	Condensation in FlowTracker2 Housing	189
11.3.6	Zinc Anodes for Corrosion Protection	189
11.4.	Seeding.....	190
11.4.1	Scattering Material	190
11.4.2	Field Applications	190
11.5.	Troubleshooting	191
11.5.1	Cannot Turn System On	191
11.5.2	Cannot Communicate with the FlowTracker2	191
11.5.2.1	Handheld	191
11.5.2.2	Communication	191
11.5.3	Cannot Retrieve Data from Internal Recorder	192
11.5.4	Velocity Data Appears Noisy or Unreasonable	192
11.5.5	Recovery Mode	192
11.6.	Health and Safety	193
11.6.1	Planning Field Work	193
11.6.2	Communication	194
11.6.3	Measurement Site Conditions	194
Section 12. FlowTracker2 File Format.....		196
12.1.	FlowTracker2 JSON File.....	196
12.1.1	Measurement File Framework	197
12.1.2	Measurement File Structure.....	198

- 12.2. FlowTracker2 CSV Output 207
 - 12.2.1 CSV File Structure..... 207
 - 12.2.2 CSV Variables 208
- 12.3. Original FlowTracker ASCII vs JSON 216
- Section 13. Principle of Operations 224**
- 13.1. FlowTracker2 Overview 224
- 13.2. The Doppler Shift..... 224
- 13.3. Bistatic Doppler Current Meters 225
 - 13.3.1 Bistatic Doppler Operation 225
 - 13.3.2 The FlowTracker2 Measurement Principle 225
 - 13.3.3 Signal to Noise Ratio Profile 226
- 13.4. Pulse-Coherent Processing 227
- 13.5. Beam Geometry and 3D Velocity Measurements 228
- 13.6. Sampling Volume Definition 228
- 13.7. Velocity Data Coordinate System 229
 - 13.7.1 2D Side-Looking Probe (Figure 30a) 229
 - 13.7.2 2D/3D Side-Looking Probe (Figure 30b)..... 229
- 13.8. FlowTracker2 Data..... 230
 - 13.8.1 Basic Sampling Strategy 230
 - 13.8.2 Velocity Data 230
 - 13.8.3 Accuracy of Velocity Data 230
 - 13.8.3.1 Optimizing of FlowTracker2 230
 - 13.8.3.2 Factors Influencing Accuracy 231
 - 13.8.4 Quality Control Data 231
- 13.9. Special Considerations 231
 - 13.9.1 Probe Configurations 231
 - 13.9.1.1 Probe mounting..... 231
 - 13.9.1.2 Probe type 231
- 13.10. Sound Speed..... 232
 - 13.10.1 Sound Speed Function..... 232
 - 13.10.2 Compensate for Changes 232
 - 13.10.3 Environmental Conditions 232
- 13.11. Flow Interference 233
 - 13.11.1 Structures 233
 - 13.11.2 Probe orientation relative to flow 233
 - 13.11.3 Mounting Correction 234
 - 13.11.3.1 No Correction 234
 - 13.11.3.2 Custom Correction 234
- 13.12. Dynamic Pressure (Pressure Sensor) 235
- Section 14. FlowTracker2 Desktop Software 237**

14.1.	Overview of Software Features and Functions	237
14.2.	Installing Software.....	238
14.3.	Changing Settings.....	239
14.3.1	User Interface Tab.....	239
14.3.1.1	Changing Language (Settings > User Interface > Language).....	239
14.3.1.2	Changing Scale and Font Size (Settings > User Interface > Scale)	240
14.3.2	General Tab	240
14.3.2.1	Show paired device connection options (Settings > General > Show paired device connection options).....	240
14.3.2.2	Show Download Options Dialog (Settings > General > Show download options dialog) ..	241
14.3.2.3	Check for Crash Reports and Send to SonTek Support (Settings > General > Check for crash reports)	241
14.3.2.4	Lab-Adv (Settings > General > Lab-Adv)	241
14.3.3	Units Tab	242
14.3.3.1	Changing Software Units (Settings > Units)	242
14.3.3.2	Changing Software Display Decimals (Settings > Units)	243
14.3.4	PDF Format.....	244
14.3.4.1	Icon Image (Settings > PDF Format > PDF icon image file location).....	244
14.3.4.2	Image Height (Settings > PDF Format > PDF icon image height in centimeters)	244
14.3.4.3	Header Text (Settings > PDF Format > PDF Header Text)	245
14.3.4.4	Include File Information (Settings > PDF Format > Include these items in the file information box)	245
14.3.4.5	Include Charts and Tables (Settings > PDF Format > Include these charts and tables)	245
14.3.4.6	Include Information Boxes (Settings > PDF Format > Include these information boxes on the first page).....	245
14.4.	Utilities	247
14.4.1	FlowTracker1 Import (Utilities > FlowTracker1 Import)	247
14.4.2	Run Translator (Utilities > Run Translator).....	248
14.4.3	Import Language File (Utilities > Import Language File).....	248
14.4.4	New Discharge Template (Utilities > New Discharge Template).....	248
14.4.5	New General Template (Utilities > New General Template)	249
14.4.6	Multiple Templates (Utilities > Multiple Templates).....	249
14.5.	Connecting to the FlowTracker2 Handheld ADV	250
14.5.1	USB Connection (Device > USB).....	251
14.5.2	Bluetooth Connection.....	251
14.6.	Device Menu and Functions	252
14.6.1	Download Data Files (Device > [Choose your connection] > Download)	253
14.6.2	Delete Data files (Device > [Choose your connection] > Delete)	255
14.6.3	Upgrading FlowTracker2 Firmware (Device > [Choose your connection] > Upgrade).....	255
14.6.4	Uploading and Downloading Templates (Device > [Choose your connection] > Templates) 256	
14.6.5	Custom Localization.....	257
14.6.6	Disconnecting the FlowTracker2.....	257
14.7.	Opening a Data File	257
14.7.1	Opening FlowTracker2 Handheld ADV Data Files (.ft files).....	258
14.7.2	Opening FlowTracker2 BeamCheck Files (.ft_beamcheck).....	258

14.7.3	Opening FlowTracker2 Template Files (.ft_template).....	260
14.7.4	Opening Original FlowTracker Handheld ADV Data Files (.WAD files).....	261
14.8.	Overview of View Data Options	263
14.8.1	Measurement Summary Pane	264
14.8.2	Main Viewing Pane.....	265
14.8.2.1	Section	265
14.8.2.2	Stations	266
14.8.2.3	Samples	268
14.8.2.4	Area.....	269
14.8.2.5	Sensors	270
14.8.2.6	Supplemental Data.....	271
14.8.2.7	Diagnostics.....	272
14.8.2.8	Summary.....	273
14.8.3	Settings Pane.....	273
14.9.	Post-Processing FlowTracker Measurements	275
14.9.1	Enable Editing	275
14.9.1.1	FlowTracker2 .ft File Editing	275
14.9.1.2	Original FlowTracker .wad File Editing	276
14.9.2	Editing through the Settings Pane.....	277
14.9.3	Editing by Station	278
14.9.4	Editing Supplemental Data.....	281
14.10.	Data Export and File Formats.....	281
14.10.1	Export Discharge Summary to PDF	281
14.10.2	Export Files to ASCII.....	283
14.10.3	Matlab Tools for JSON files	284
Section 15.	FlowTracker2 Lab-ADV.....	285
15.1.	Lab-ADV Software Feature.....	285
15.2.	Enable Lab-ADV feature	286
15.3.	Lab-ADV Configuration.....	287
15.3.1	Load Configuration.....	290
15.3.2	Save Configuration.....	290
15.3.3	Beam Check.....	290
15.3.4	Probe Info.....	291
15.3.5	Force Firmware Upgrade	292
15.4.	Data Collection.....	292
15.4.1	Display Settings.....	293
15.4.2	Information	293
15.5.	Data Export.....	294
15.6.	Power and Communication Cable.....	296
Appendix A.	Software Flow Diagram.....	298
Appendix B.	Site Selection Requirements	300
Appendix C.	Japanese Method Example.....	301

Appendix D. Measurement Equipment List 302
Appendix E. CE Declaration of Conformity..... 303
INDEX 305

List of Tables

<i>Table 3:1 – Beeper Options</i>	31
<i>Table 3:2 – FlowTracker2 Display Units</i>	33
<i>Table 3:3 - Wading Rod Graphics</i>	34
<i>Table 3:4 - File Naming Conventions</i>	35
<i>Table 3:5 - GPS Status Icons</i>	37
<i>Table 3:6 - Air Pressure Cal. Period - Properties</i>	38
<i>Table 3:7 - File Properties - Properties</i>	43
<i>Table 3:8 - Data Collection Settings - Properties</i>	44
<i>Table 3:9 - Quality Control Settings - Properties</i>	47
<i>Table 3:10 - Discharge Settings - Properties</i>	49
<i>Table 3:11 - Displayed Velocity Methods - Properties</i>	53
<i>Table 4:1 - Date and Time - Properties</i>	55
<i>Table 4:2 - File Types - Properties</i>	56
<i>Table 4:3 - Raw Velocity Display</i>	60
<i>Table 4:4 - Beam SNR Display</i>	62
<i>Table 4:5 – Battery Specification</i>	63
<i>Table 4:6 - Automated Beam Check Display</i>	64
<i>Table 4:7 - GPS Data - Properties</i>	66
<i>Table 5:1 - Predetermination of Measuring Intervals</i>	74
<i>Table 5:2 - Determining Mean Station Velocity</i>	76
<i>Table 5:3 – Correction Factors</i>	78
<i>Table 6:1 - Quality Control Parameters</i>	83
<i>Table 6:2 – SNR Data Types</i>	85
<i>Table 6:3 – σV Data Types</i>	87
<i>Table 6:4 - Quality Control Warning Messages</i>	96
<i>Table 6:5 - Timing of Quality Control Warning Messages</i>	98
<i>Table 6:6 - Automated Beam Check Quality Control Criteria</i>	104
<i>Table 6:7 - Automated Beam Check Display</i>	105
<i>Table 7:1 - Hardware Inspection</i>	108
<i>Table 7:2 - Office Diagnostics</i>	109
<i>Table 7:3 – Measure Site Information</i>	110
<i>Table 7:4 - Pre Measurement Diagnostics</i>	111
<i>Table 8:1 - Automated Beam Check Quality Control Criteria</i>	120
<i>Table 8:2 - Automated Beam Check Display</i>	122
<i>Table 8:3 - Incompatible Velocity Methods and Station Types</i>	126
<i>Table 8:4 - Bank Station Type - Properties</i>	127
<i>Table 8:5 - Island Edge Station Type - Properties</i>	128
<i>Table 8:6 - Open Water Station Type - Properties</i>	129
<i>Table 8:7 - Ice Station Type - Properties</i>	130

<i>Table 8:8 - Review Point Measurement</i>	135
<i>Table 8:9 - Review Station</i>	136
<i>Table 8:10 - Review Point Measurement</i>	142
<i>Table 8:11 - Review Station</i>	144
<i>Table 8:12 - Discharge Summary</i>	147
<i>Table 8:13 - Station Summary</i>	148
<i>Table 8:14 - Measurement Summary</i>	153
<i>Table 9:1 - Automated Beam Check Quality Control Criteria</i>	157
<i>Table 9:2 - Automated Beam Check Display</i>	159
<i>Table 9:3 - Station - Properties</i>	160
<i>Table 9:4 - Review Point Measurement</i>	164
<i>Table 9:5 - Review Station</i>	165
<i>Table 9:6 - Review Point Measurement</i>	170
<i>Table 9:7 - Review Station</i>	171
<i>Table 9:8 - Velocity Summary</i>	173
<i>Table 9:9 - Measurement Summary</i>	177
<i>Table 10:1- ADV Probe Specifications</i>	179
<i>Table 10:2- Handheld Specifications</i>	180
<i>Table 10:3- Cable and Connector Specifications</i>	181
<i>Table 12:1 - CSV File Types</i>	207
<i>Table 12:2 - CSV Row and Column</i>	207
<i>Table 12:3 - Control File Variables</i>	208
<i>Table 12:4 - Raw Data File Variables</i>	209
<i>Table 12:5 - Discharge File Variables</i>	209
<i>Table 12:6 - Summary File Variables</i>	213
<i>Table 13:1- Sampling Strategy</i>	230
<i>Table 14:1- Units Available for Software Parameters</i>	242
<i>Table 14:2. Original FlowTracker File Format Import</i>	262
<i>Table 14:3. Measurement Summary Pane</i>	264
<i>Table 14:4: Station Information Values Available</i>	266
<i>Table 14:5. Summary of Settings Pane Values</i>	273
<i>Table 15:1. Configuration Settings</i>	287
<i>Table 15:2. CSV Data Export</i>	294
<i>Table 15:3. FlowTracker2 Lab-Adv Hardware Components</i>	296

List of Equations

Equation 5:1 - Mid-Section Method 71
Equation 5:2 - Mean-Section Method..... 72
Equation 5:3 - Japanese Method > 10m 74
Equation 5:4 - Japanese Method < 10m 74
Equation 5:5 - Discharge Weighted..... 81
Equation 5:6 - Time Weighted..... 81
Equation 13:1 – Total Pressure..... 235
Equation 13:2 – Dynamic Pressure..... 235
Equation 13:3 – Corrected AdvWaterSpeed 235
Equation 13:4 – Dynamic Pressure using AdvWaterSpeed 236
Equation 13:5 – Static Pressure..... 236
Equation 13:6 – Corrected Pressure 236
Equation 5:3 - Japanese Method > 10m 301

Section 1. Quick Overview

1.1. System Components

Layout of FlowTracker2 and all major components are labeled in [Figure 1:1](#).

- **Probe** – The FlowTracker2 probe ([Figure 1:2](#)) contains the acoustic elements to measure velocity. See [Principle of Operations](#) for more information.
- **Keypad** – The FlowTracker2 keypad is designed for quick and efficient software operation, configuration and data entry.
- **Handheld** - The handheld contains the processing electronics, batteries, keypad, and LCD screen. The handheld is designed to withstand temporary submersion, but is not intended for underwater operation.
- **Battery Compartment** – Battery Compartment consist of a water tight battery cap and an AA battery cartridge for quick access and battery replacement.
- **LCD Screen** – The LCD screen display the FlowTracker2 handheld software and real-time graphical display of raw data.
- **Probe cable** – The probe is factory mounted to a 1500mm (59-in) flexible cable. The handheld connects to the probe cable with rugged underwater flexible connector. The standard cable (1500mm) supplied with the FlowTracker2 can be extended with either an 1500mm (59-in) or 3500mm (137-in) cable extension up to maximum length of 10m (32.8-ft).
- **Communication Connector** – A waterproof (IP67) micro USB connector on the bottom of the handheld connect to external communication cable



Figure 1:1 - FlowTracker2 with 2D Probe

Layout of FlowTracker2 Probe and all major components are labeled in [Figure 1:2](#)

- **Transmitter** – The acoustic transmitter generates a short pulse of sound with the majority of energy concentrated in a narrow beam (6 mm in diameter).
- **Receivers** – The acoustic receivers are mounted on arms from the central probe head. The receivers are sensitive to a narrow beam and are focused on a common volume located a fixed distance (10 cm; 4 in) from the probe. The FlowTracker2 uses two or three acoustic receivers for 2D or 3D probes. See [Beam Geometry and 3D Velocity Measurements](#) for details.
- **Sampling volume** – The sampling volume is the physical location of the water velocity measurement. See [Principle of Operations](#) for details.
- **Temperature sensor** – The temperature sensor is mounted inside the probe. Temperature data is used to compensate for changes in sound speed. Sound speed is used to convert the Doppler shift to water velocity. See [Hardware Specification](#) for details on the temperature sensor; see [Principle of Operations](#) for details about the effect of sound speed on velocity data.

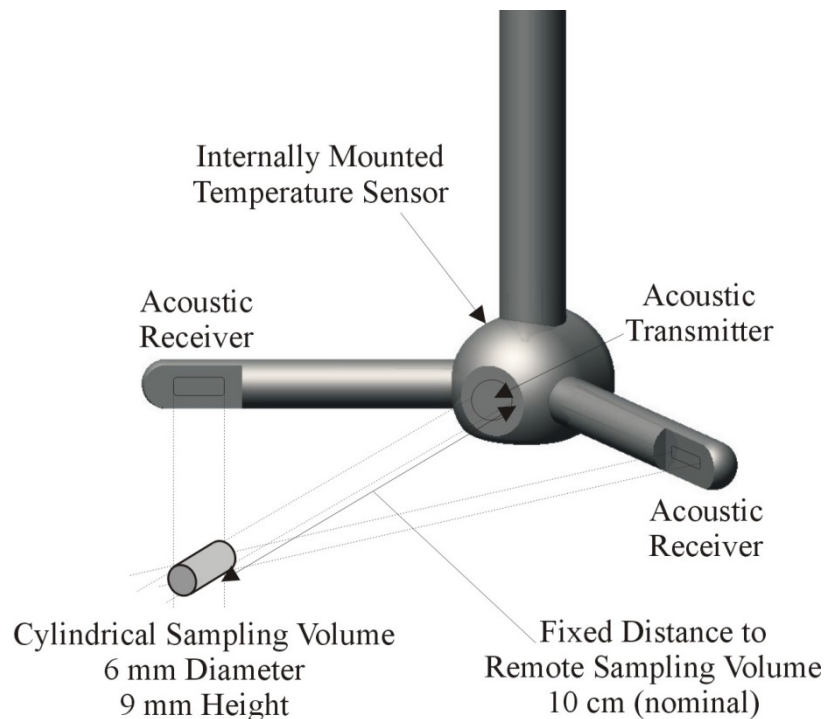

Figure 1:2 - 2D Side Looking FlowTracker2 Probe and Sampling Volume

1.2. Definitions and Terminology

This section defines terms commonly used when working with FlowTracker2

- **Averaging Time** – The time (in seconds) in which the FlowTracker2 records data at each measurement location. This is a user-specified value from 10 to 1000 seconds.
- **Handheld** – The FlowTracker2 is controlled from the keypad on the handheld. The LCD screen is used to display FlowTracker2 handheld software and real-time graphical display of raw data.
- **Measurement Location** – At each measurement location, the FlowTracker2 records one-second velocity data for the specified averaging time, location, water depth parameters and a variety of statistical and quality control data.
- **Ping Rate** – The number of pings per second (Hz). The FlowTracker2 ping rate is 40 Hz.
- **Ping** – A single estimate of the 2D or 3D water velocity.
- **Quality Control Data** – In addition to velocity, the FlowTracker2 records several quality control parameters. These include signal-to-noise ratio (SNR), standard error of velocity, boundary adjustment, the number of spikes filtered from data, and velocity angle. For details about quality control data, see [Quality Control](#) for details.
- **Salinity** – Water salinity is a user-supplied value that is used for sound speed calculations. Note: If using the system in salt water, a zinc anode should be installed on the probe for corrosion protection described in [Zinc Anodes for Corrosion Protection](#).
- **Sample** – A sample refers to the mean of 20 pings to produce a measurement of the 2D or 3D water velocity. A sample includes velocity and signal to noise ratio data. The FlowTracker2 records two samples per second.
- **Signal Strength** – This refers to the strength of the reflected acoustic signal. It is a function of the acoustic conditions of the water – primarily the amount and type of suspended material (scatterers) present. This is most commonly accessed as a signal-to-noise ratio (SNR).
- **Signal-to-Noise Ratio (SNR)** – SNR is the ratio of the received acoustic signal strength to the ambient noise level. It is expressed in logarithmic units (dB), and is the most important quality control data for the FlowTracker2, see [Quality Control](#) for details.
- **Sound Speed** – Speed of sound in water (in m/s) is used to convert the Doppler shift to velocity. See [Principle of Operations](#) regarding the effect of sound speed on velocity data.

- **Temperature** – Water temperature (in °C) is measured by the internal temperature sensor. Temperature is used for sound speed calculations.
- **UTC** - Coordinated Universal Time, abbreviated as **UTC**, is the primary time standard by which the world regulates clocks and time



WARNING! The WARNING symbol and notice highlight instructions that must be followed to avoid personal injury. Do not proceed until all stated conditions are clearly understood and met.



CAUTION! The CAUTION notice highlights instructions that must be followed to avoid damage to the product or other equipment. Do not proceed until all stated conditions are met and clearly understood.

Section 2. System Operation

The **System Operation** section describes the keypad interface, handheld software menus and the LCD display.

2.1. On/Off Switch

The On/Off power button  for the FlowTracker2 can be accessed on the right side of the keypad, 3rd row from the top.

- a) Start system, hold the power button until the LCD screen turns on.
- b) Shutdown system, hold the power button until a message is displayed to shut down the handheld.
- c) Activate sleep mode, press the power button once shutdown.
- d) Wakeup system, press any button on keypad.



It's good practice to remove the battery cartridge at the end of each workday for inspection and charging/replacement.



If the system is not used or stored for long periods, remove the batteries to prevent unnecessary draining and potential battery leakage.

2.2. Keypad

- a) **Navigation Keys** – The handheld has a number of keys that are assigned to operate handheld software. The following keys are available for the user to either navigate or select options in the software,
 - i). **Left Soft Key** – The text directly above the soft key is associated with the key operations and allows the user to perform the following actions,
 - return to previous menu,
 - select action based on text displayed,
 - restart or cancel current operation.
 - ii). **Right Soft Key** - The text directly above the soft key is associated with the key operations and allows the user to perform the following actions,
 - start a new measurement,
 - accept data entry or operation,
 - create new template,
 - access the quality control menu.
 - iii). **Left & Right arrow** – The key allows the user to perform the following actions,



Figure 2:1 - Keypad Layout

- select different options under each parameter in configuration,
 - select station type or velocity method in measurement,
 - select station in data collection.
- iv). **Top & Bottom arrow** – The key allows the user to perform the following actions,
- scroll through the menu options,
 - select files or templates,
 - display graphics during data collection,
 - scroll through the measurement, station and discharge summary reports.
- b) **Enter Key** – The enter key (square) is situated between the four arrow keys and allow the user to perform the following actions,
- i). Select the menu item in the menus
 - ii). Activate or deactivate running average during the beam-check data collection. This information is only displayed graphically and will not be stored in the data files.
- c) **Numbers (0-9)** – The keys allows the user to perform the following actions. Numbers will default to the first option on the key if only numerical values are required in the entry field.
- i). Menu shortcut (number next to text) associated with each menu item.
 - ii). Configuration of instrument such, data collection settings, quality control parameters and discharge settings
 - iii). Enter measurement data such, station location, depth and other information.
- d) **Letters (A-Z)** – The keys allows the user to perform the following actions. Letters will default to the first option on the key if letters are required in the entry field.
- i). Create file and template names,
 - ii). Enter comments at a station, supplement data or overall measurement.
- e) **Backspace** – The key allows the user to perform the following delete actions,
- i). Text or values in user entry fields,
 - ii). Data file folder with all content or individual data files,



Figure 2:2 - Keypad Layout

iii). Selected station in Discharge and General mode.



Text entry is done in the same manner as for mobile devices.

- numerical fields, the text entry assumes numbers first (i.e. for “2” press **2** key one time, **2 – A – B – C**);
- text fields, it assumes letters first (i.e. for “B” press **2** key two times, **A – B – C**)

2.3. Keypad Filter

The FlowTracker2 handheld keypad filter enables the user to filter data or template files based on the keystrokes entered on the handheld. This feature is available to all tables with row selection functionality (rows that can be selected by using either the up or down arrows keys), such as templates selection, opening data files, etc.

Keypad Filter feature operate by filtering file names based on the keystrokes entered by the user. The files filtered in Figure 2.3 was based on the following three key strokes,

- 1st Key: **3DEF**
- 2nd Key: **1**
- 3rd Key: **4GHI**

The order of the keystrokes should be based on the order of the first couple of characters or specific wording in the file name. The software will search for any combination of characters available on the keys.

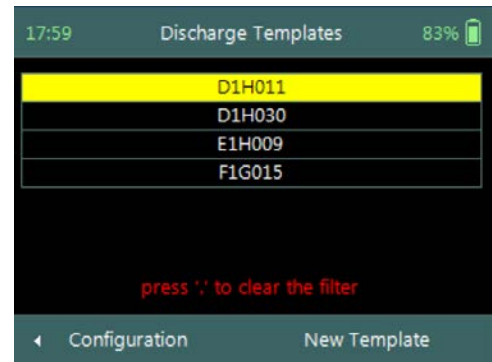

Figure 2:3 – Keypad Filter

2.4. Screen Layout

The Screen Layout of the FlowTracker2 consists of the following main features. The options or information displayed may vary from one screen to the next based on the software features that are used.

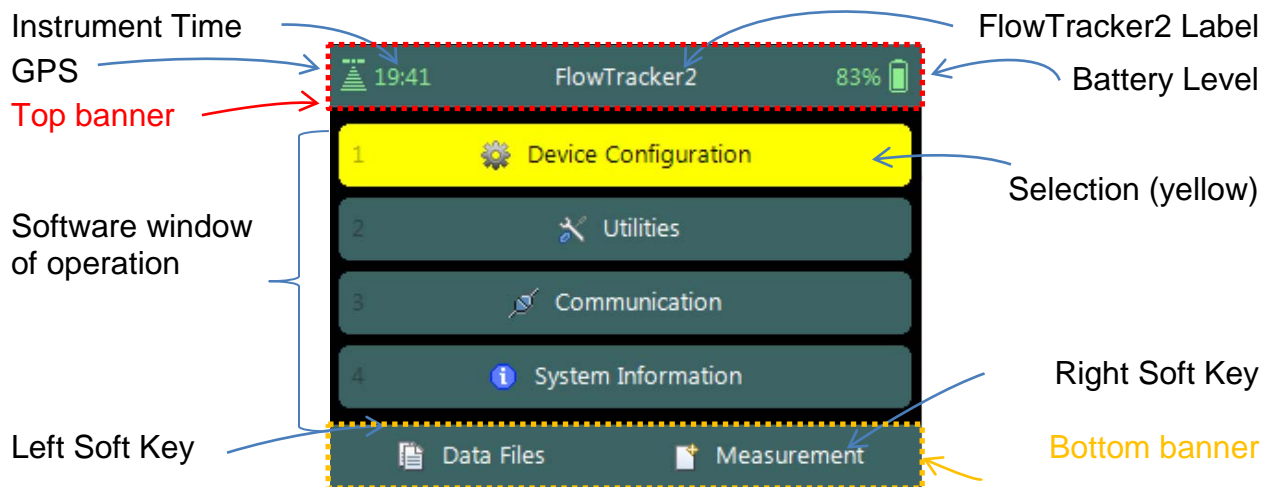

Figure 2:4 - Screen Layout

2.5. Main Menu

When the FlowTracker2 handheld is switched on the FlowTracker2 image is displayed during the startup process. Flow diagram of the handheld software is supplied in [Software Flow Diagram](#) for both the Discharge and General modes.



FlowTracker2 software layout of the handheld is similar to the “Original FlowTracker” consisting of the same three main groups, although the wording has changed.

The **Main Menu** of the handheld software is displayed after the startup process of the FlowTracker2 is completed.

Main menu consists of four menu options,

- a) Device Configuration,
- b) Utilities,
- c) Communication,
- d) System Information
- e) *To select a menu option,*
 - i). Use up or down scroll arrows keys to select menu option,
 - ii). The menu option selected will be highlighted in yellow,
 - iii). Press the enter key to access the menu option.

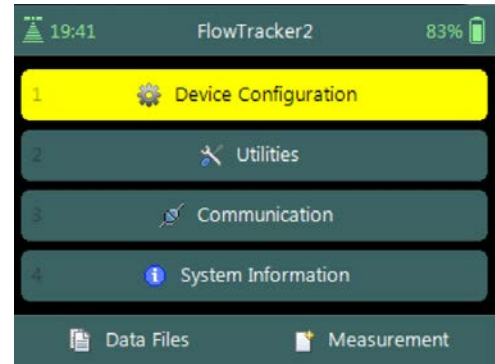

Figure 2:5 - Main Menu

There are also two additional menu options “Data Files” and “Measurement” available to the user that is situated in the bottom banner of the screen.

- f) *To select Data Files or Measurement functions,*
 - i). Data Files – Press the Left Soft Key,
 - ii). Measurement – Press the Right Soft Key.



The number opposite each menu option is a shortcut key (i.e. pressing “2” key will access the Utilities menu).

2.5.1 Device Configuration Menu (Main Menu)

The **Device Configuration Menu** configures how the FlowTracker2 collects data, performs internal discharge calculations, evaluate data against data quality parameters and finally determine uncertainty of the measurements based on the method selected.

Device Configuration menu consists of four menu options,

- a) User Interface,
- b) Application Settings,
- c) Discharge Templates,
- d) General Templates.
- e) *To select a menu option,*
 - i). Use up or down scroll arrows keys to select menu option,
 - ii). The menu option selected will be highlighted in yellow,
 - iii). Press the enter key to access the menu option.
- f) *To navigate to Main Menu,*
 - i). Press the Left Soft Key.

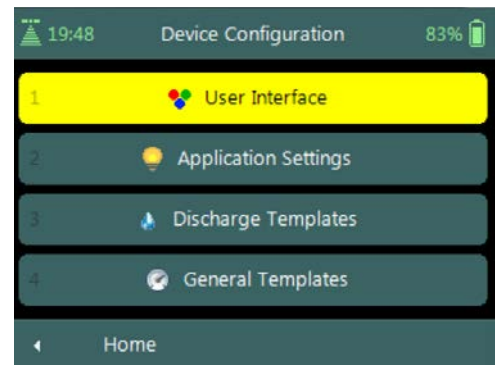

Figure 2:6 - Device Configuration Menu

2.5.2 Utilities (Main Menu)

The **Utilities Menu** accesses internal system functions of the FlowTracker2. The available functions assists with setting the internal clock and power source, management of recorder, displaying raw velocity and GPS data and performing tests on measurement and boundary conditions.

Utilities menu consists of the following menu options,

- a) System Clock,
 - b) Recorder,
 - c) Battery Data,
 - d) Raw Data,
 - e) Automated Beam Check,
 - f) Beam Check,
 - g) GPS Data.
- h) *To select a menu option,*
- i). Use up or down scroll arrows keys to select menu option,
 - ii). The menu option selected will be highlighted in yellow,
 - iii). Press the enter key to access the menu option.
- i) *To navigate to Main Menu,*
- i). Press the Left Soft Key.

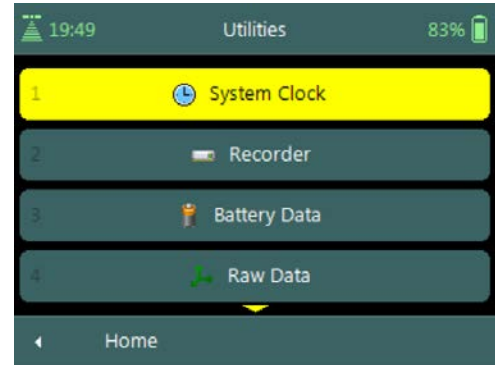

Figure 2:7 - Utilities Menu



The Utilities Menu provides access to functions that should be checked periodically, but do not directly affect how data is collected.

2.5.3 Communication (Main Menu)

The **Communication** function permits communication between an external device equipped with the FlowTracker2 Desktop Software and the handheld. Communication between the desktop software and handheld can be established by using either a Micro USB cable or Bluetooth. See [Connecting to the FlowTracker2 Handheld ADV](#) for details of hardware and configuration requirements to enable communication.



The Communication function on the handheld software must be activated first before the connection feature is selected on the FlowTracker2 desktop software.

2.5.4 System Information (Main Menu)

The **System Information** screen displays the system information of the FlowTracker2 for both the Handheld and Probe, with the serial number and firmware versions as the key data sets.

Handheld System Information of the FlowTracker2 includes the following system information,

- a) Device (FlowTracker2 Handheld),
- b) Serial Number (123456),
- c) Upgraded Firmware (V0.14.7).
- d) *To navigate to Main Menu or Probe Information,*
 - i). Main Menu – Press the Left Soft Key,
 - ii). Probe Information – Press the Right Soft Key.



Figure 2:8 - Handheld System Information

Probe System Information of the FlowTracker2 includes the following system information,

- a) Device (FlowTracker2 Probe),
- b) Serial Number (123456),
- c) Probe Firmware (V0.14.7),
- d) Number of Beams (2 or 3).
- e) *To navigate to Main Menu,*
 - i). Press the Left Soft Key two times.

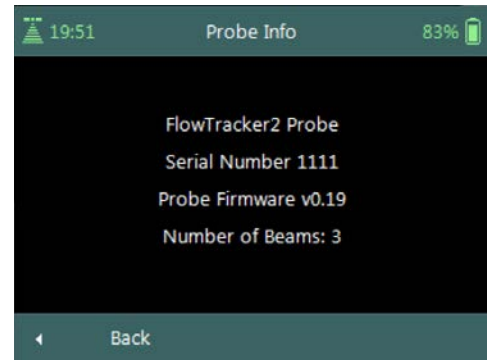

Figure 2:9 - Probe System Information

2.5.5 Measurement (Main Menu)

The **Measurement** function is the main component of the FlowTracker2 handheld software and includes two measurement modes. The Discharge mode is for applications where the primary goal is to measure river/stream discharge. The technique involves taking a series of velocity measurements at different locations throughout the cross section. These measurements are combined with location and water depth information to compute the total discharge. The General mode is designed to perform a series of velocity measurements at different locations, but does not provide discharge as an output.

The methods and techniques implemented for determining the mean station velocity, calculation of discharge and uncertainty analysis of a measurement are based on the following literature,



- ISO 748 – 2007, Hydrometry - Measurement of liquid flow in open channels using current meters or floats,
- WMO-No. 1044, Volume I – Fieldwork, 2010.
- IVE, Quantifying Uncertainty in Discharge Measurements: A New Approach

Measurement function consists of two measurement modes in the menu,

- a) Discharge,
- b) General.
- c) *To select a menu option,*
 - i). Use up or down scroll arrows keys to select menu option,
 - ii). The menu option selected will be highlighted in yellow,
 - iii). Press the enter key to access the menu option.
- d) *To navigate to Main Menu,*
 - i). Press the Left Soft Key.

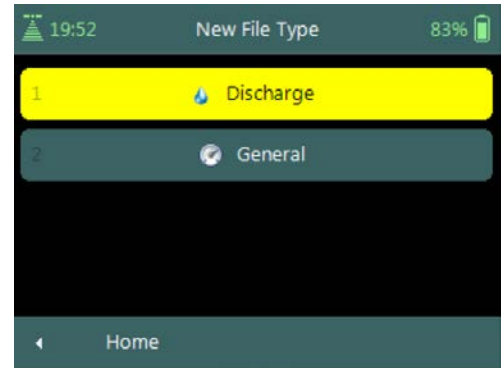

Figure 2:10 - Measurement

2.5.6 Data Files (Main Menu)

The **Data Files** function displays the recorder contents and gives the user access to FlowTracker2 measurements files.

The FlowTracker2 measurement files can be organized in the recorder based on the following user defined folder naming conventions,



- Site Name,
- Site Number,
- Month.

Data Files screen displays a list of folders based on the naming convention. Each folder can consist of either a single or multiple measurement files.

- a) *To select a measurement folder,*
 - i). Use up or down scroll arrows keys to select folder,
 - ii). The folder will be highlighted in yellow,
 - iii). Press the enter key to access the folder content,
 - iv). Selecting a measurement file in the folder, follow steps i to iii.
- b) *To **DELETE** a measurement file or folder*
 - i). Use up or down scroll arrows keys to select folder or file,
 - ii). The folder or file will be highlighted in yellow,
 - iii). Press backspace to delete the folder or file.
 - iv). The operator will be requested to confirm deletion of the files or folders.
- c) *To navigate to Main Menu,*
 - i). Press the Left Soft Key.

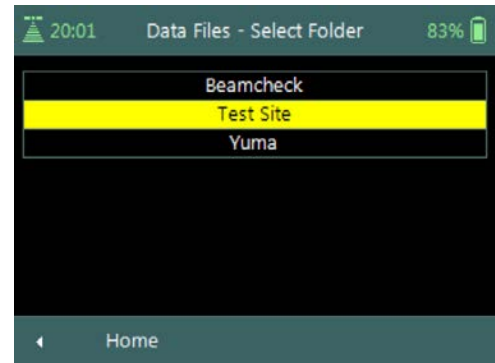

Figure 2:11 - Data Files

Before any measurement files and or folders are deleted please ensure that the following steps are performed,



- Download all measurement files using the FlowTracker2 desktop software,
- Ensure that measurement files are stored in a secure location on PC or Tablet,
- Create a secondary backup of the measurement files by copying to external USB or network drive.

The delete process is irreversible and the user will not be able to retrieve the measurement files once this action is performed.

Section 3. Device Configuration

3.1. User Interface

User Interface defines the settings related to interaction (view and audio) between the operator and the device.

User Interface screen includes the following parameters,

- a) Language,
- b) Use Beeper,
- c) Color Scheme,
- d) Font Size,
- e) *To select a parameter,*
 - i). Use up or down scroll arrows keys to select a parameter,
 - ii). The parameter selected will be highlighted in yellow.
- f) *To navigate to Configuration Menu,*
 - i). Press the Left Soft Key.

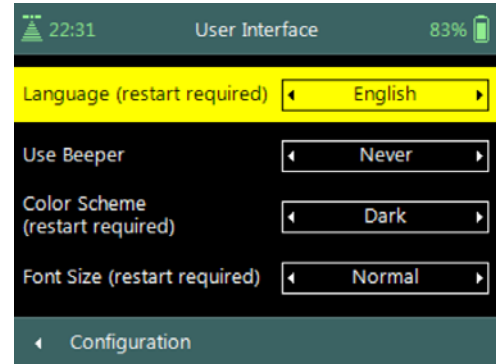

Figure 3:1 - User Interface

3.1.1 Language

The list of **Predefined Languages** supported in FlowTracker2 handheld software is grouped under the following.

- a) Default language – English (US),
- b) Other – Chinese-Simplified, Chinese Traditional, French, German, Italian, Japanese, Korean, Portuguese, Russian, Spanish and Catalan.
- c) More languages will be added to FlowTracker2 in subsequent revisions as SonTek receives translation files. Please contact SonTek if you use the FlowTracker2 desktop software translator tool to create translation files you wish to share.
- d) *To change the Language,*
 - i). Use the left or right arrow key to scroll through the list of available languages.
 - ii). Press the Left Soft Key to return to Configuration for the software to accept the change.



Additional languages can be uploaded on the FlowTracker2 handheld using the **FlowTracker2 Translator** function available in the FlowTracker2 desktop software. The process involved in creating translation files and uploading to the handheld is described in [FlowTracker2 Desktop Software](#).



If you selected a wrong language the menu functions can be a bit hazy! The following steps will get you out of the gate.

i) the main menu must be displayed, **ii)** top menu option must be highlighted, **iii)** press the enter key two times, **iv)** use left or right arrow key to select different language, **v)** press left soft key two times, **vi)** handheld software will restart with new selected language.

3.1.2 Use Beeper

An internal speaker is available in the handheld to create a “**Beep**” after certain functions are completed or warning thresholds exceeded in the handheld software.

- a) The Beeper options implemented in FlowTracker2 are categorized under the following,
 - i). Always,
 - ii). Major Events,
 - iii). Never.
- b) [Table 3:1](#) list the Beeper options and functions that will create a beep during operations.

Table 3-1 – Beeper Options

Option		Function
Always	Major Events	On startup
		Maximum screen brightness
		Measurement completed in point measurement view
		Tilt exceeds threshold in point measurement
		Automated BeamCheck completed
	Warning present in Report	

- c) *To change the Beeper option,*
 - i). Use the left or right arrow key to select Beeper option,
 - ii). Press the Left Soft Key to return to Configuration for the software to accept the change.

3.1.3 Color Scheme

Color Schemes give the operator the ability to improve visibility of the LCD display under different light conditions that may be experienced during field work.

- a) Color schemes implemented in FlowTracker2 are categorized under the following schemes,
 - i). Light,
 - ii). Medium,
 - iii). Dark.
- b) *To change the Color Scheme option,*
 - i). Use the left or right arrow key to scroll through the list of available color schemes,

- ii). Press the Left Soft Key to return to Configuration for the software to accept the change.

3.1.4 Font Size

Font Sizes give the operator the ability to improve visibility of text on the LCD display under different light conditions that may be experienced during field work.

- a) Font sizes implemented in FlowTracker2 are categorized under the following schemes,
 - i). Normal,
 - ii). Large,
 - iii). Extra Large.
- b) *To change the Font Size,*
 - i). Use the left or right arrow key to scroll through the list of available font sizes,
 - ii). Press the Left Soft Key to return to Configuration for the software to accept the change.

3.2. Application Settings

Application Settings define the operator requirements with respect to the units system used, management of measurement files and overall GPS operation during data collection.

Application Settings screen includes following parameters,

- a) Units,
- b) Wading Rod,
- c) File Naming,
- d) Folder Naming,
- e) GPS Station Tagging,
- f) Use Pressure Sensor (PS Required),
- g) Probe Offset From WR Bottom,
- h) Air Pressure Cal. Period (min).

Pressure
Sensor

- i) *To select a parameter,*
 - i). Use up or down scroll arrows keys to select a parameter,
 - ii). The parameter selected will be highlighted in yellow.
- j) *To navigate to Configuration Menu,*
 - i). Press the Left Soft Key.

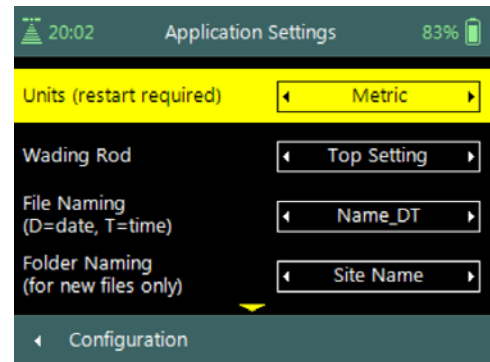

Figure 3:2 - Application Settings

3.2.1 Units

The **Units** function defines the **Units System** used for displaying and outputting measurement data.

- a) The Units Systems supported in FlowTracker2 is grouped under the following,
 - i). Metric,
 - ii). English,
- b) The internal unit system used is Metric and this does not affect internal calculations or data storage,
- c) [Table 3:2](#) list the units that are used for display.

Table 3-2 – FlowTracker2 Display Units

Parameter	English Units	Metric Units
Location	feet	meters
Depth	feet	meters
Pressure	dbar	dbar
Velocity	ft/s	m/s
Standard error of velocity	ft/s	m/s
Staff / Gauge height	feet	meters
Discharge	ft ³ /s	m ³ /s
SNR	dB	dB

- d) *To **change the Unit option**,*
 - i). Use the left or right arrow key to scroll through the list of options,
 - ii). Press the Left Soft Key to return to Configuration for the software to accept the change.

3.2.2 Wading Rod

Wading Rod function gives the operator the choice of what type of wading rod is used during the measurement.

The selection of the type of wading rod will impact what graphics are displayed during the data collection process and what reference (water surface or bottom) is used in determining instrument depth.

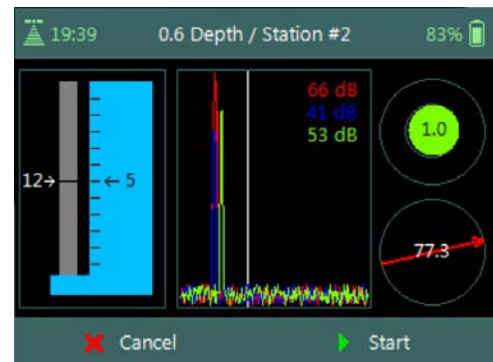
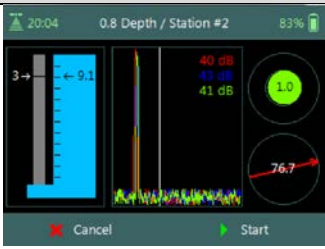
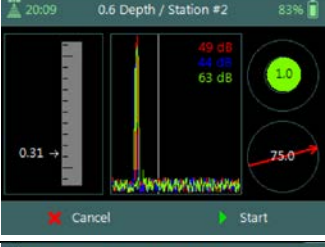
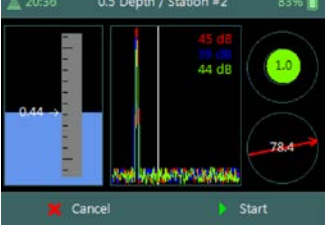

Figure 3:3 - Top Setting Wading Rod Graphic

- a) The Wading Rods supported in FlowTracker2 are grouped under the following,

- i). Top-Setting (Instrument referenced to water surface)
 - ii). Universal (Instrument referenced to bottom)
 - iii). Ice (Instrument referenced to water surface)
 - iv). Unknown
- b) The graphic representation of the Wading Rods supported and the fractional depth indicators are defined in [Table 3:3](#),

Table 3-3 - Wading Rod Graphics

Wading Rod	Graphic	Wading Rod Setting	Example	Reference
Top Setting		$= \left[\frac{(1 - f_{depth}) \times w_{depth}}{0.4} \right]$ <p>f_{depth} – Fractional Depth w_{depth} – Water Depth</p>	$w_{depth} = 0.783m$ $f_{depth} = 0.8$ Rod = 0.391	Water Surface
Universal		$= w_{depth} - (f_{depth} \times w_{depth})$ <p>f_{depth} – Fractional Depth w_{depth} – Water Depth</p>	$w_{depth} = 0.783m$ $f_{depth} = 0.6$ Rod = 0.313	Channel Bed
Ice		$= w_{depth} - \left[(w_{depth} - w_{depth - ice}) \times (1 - f_{depth}) \right]$ <p>f_{depth} – Fractional Depth w_{depth} – Water Depth $l_{thickness}$ = Ice Thickness $w_{depth - ice}$ = Water Surface to Bottom of Ice</p>	$w_{depth} = 0.783m$ $f_{depth} = 0.5$ $l_{thickness} = 0.2m$ $w_{depth - ice} = 0.1m$ Rod = 0.442	Water Surface

- c) To **change** the Wading Rod type,
- i). Use the left or right arrow key to scroll through the list of options,
 - ii). Press the Left Soft Key to return to Configuration for the software to accept the change.

3.2.3 File Naming

The **File Naming** function enables the operator to assign a unique name for each measurement file. The file naming process in FlowTracker2 ensures that existing measurement files are not overwritten.

- a) The file naming conventions that are supported in FlowTracker2 software are listed in [Table 3:4](#),

Table 3-4 - File Naming Conventions

Naming Convention	Description	Example
Number	Site Number	09429500
Number_Date	Site Number_yyyymmdd	09429500_20151013
Number_DT	Site Number_yyyymmdd-hhmmss	09429500_20151013-170220
Date_Number	yyymmdd_Site Number	20151013_09429500
DT_Number	yyymmdd-hhmmss_Site Number	20151013-170220_09429500
Name	Site Name	Colorado
Name_Date	Site Name_yyyymmdd	Colorado_20151013
Name_DT	Site Name_yyyymmdd-hhmmss	Colorado_20151013-170220
Date_Name	yyymmdd_Site Name	20151013_Colorado
DT_Name	yyymmdd-hhmmss_Site Name	20151013-170220_Colorado

- b) A **Follow Number** is incorporated at the end of the new file name, if there are files in the recorder with the same file name. The **follow number** will increase incrementally for every new file created with the same file name (e.g. 09429500_20151013_3)
- c) To **change the File Naming convention**,
- i). Use the left or right arrow key to scroll through the list of options,
 - ii). Press the Left Soft Key to return to Configuration for the software to accept the change.

It's recommended that file the naming convention used contains both the date and time. This will ensure that a unique file name is created for each measurement and can easily be sorted in Windows explorer when downloaded from FlowTracker2 handheld,



- yyymmdd-hhmmss_Site Number,
- yyymmdd-hhmmss_Site Name.

3.2.4 Folder Naming

The **Folder Naming** function enables the operator to organize measurement files in the recorder by grouping by site or month.

- a) The folder naming conventions that are supported in FlowTracker2 software are grouped under the following,
- i). Site Number,
 - ii). Site Name,
 - iii). yyyy-mm.
- b) A folder is created automatically in the recorder when a measurement file is created based on the folder naming convention. If all the measurement files are deleted, the folder will be removed from the recorder.
- c) To **change the Folder Naming convention**,
- i). Use the left or right arrow key to scroll through the list of options,

- ii). Press the Left Soft Key to return to Configuration for the software to accept the change.

3.2.5 GPS Station Tagging

The **GPS Station Tagging** function allows the operator control over the GPS operation during measurements.

- a) The GPS options that are supported in FlowTracker2 software are grouped under the following,
- i). **Automatic.** The automatic option for the GPS allows the FlowTracker2 to perform GPS measurements at each station without any additional interaction with the software.
- The GPS receiver is *Continuously Operating* and receiving data from satellites when the FlowTracker2 handheld is activated.
 - If a GPS lock is not obtained before the station measurement is completed, the software will not record positional information for the station. The GPS status Icons are listed in [Table 3:4](#).
 - The positional information is averaged over the time a station is created to improve the overall measurement accuracy. The software starts averaging the positional information when the *Add Station* function is selected and stops when the station is completed, from where the averaged position is recorded against the station. The averaging process is performed for both Discharge and General modes.
 - When editing an existing station and Automatic GPS mode is selected, the logic reverts to “Manual GPS” mode to ensure that a position is not assigned while editing away from the actual station location.





The operator needs to ensure that the wading rod is placed in the correct position and vertical before the “Add Station” function is selected. This will improve the overall accuracy of the GPS measurement.

- ii). **Manual.** The manual option provides the operator control over GPS measurements and requires the operator to select “Record GPS Location” function before velocity measurements are made at a station for both Discharge and General modes.
- The GPS receiver is on *Cold Start and is NOT* receiving data from satellites.
 - The manual GPS measurement option forms part of the “Add Station” configuration screen and is located at the bottom of the screen. The “Record GPS Location” function can be accessed by using the Bottom Arrow.

- If a GPS lock is not obtained before the station measurement is completed, the software will not record positional information for the station. The GPS status Icons are listed in [Table 3:4](#).
 - The positional information is averaged when the “Record GPS Location” function is selected. The period of averaging the positional information is dependent on the user and a counter will display the number of measurements averaged.
 - The “Record GPS location” at the bottom of the configuration screen will state “Record GPS location” if no location is assigned yet and “Update GPS location” if a location is already assigned.
- iii). **Disabled.** The GPS is disabled and the operator will not be able to perform any GPS measurements.
- b) The status of GPS lock is indicated by GPS icon displayed on the left corner of the top banner of the LCD screen. The icon’s describing the GPS status in the handheld is defined in [Table 3:5](#),

Table 3-5 - GPS Status Icons

Icon	Description	Conditions
	Attempting to acquire satellite signal.	GPS has not acquired any satellite signal or GPS lock and is unable to determine positional information
	Acquiring satellite signal in progress.	GPS is acquiring additional satellite signals, low quality positional information available, number of satellites < 4 and or HDOP > 2.5.
	Satellite signal acquired from available satellites.	GPS lock is obtained, high quality positional information available.

- c) The averaging of positional information from the internal GPS is based on the following criteria,
- i). Averaging is limited to 1000 records. If more than 1000 records are reported – the oldest records are dropped.
 - ii). Averaging is performed only when 5 or more records are recorded, otherwise the record with the lowest HDOP/max satellites is used.
 - iii). If 10 or more “high quality records” are recorded – only high quality records are used for the averaging. Otherwise both high/low quality records are used for the averaging.
- d) *To **change** the GPS station tagging option,*
- i). Use the left or right arrow key to scroll through the list of options,

- ii). Press the Left Soft Key to return to Configuration for the software to accept the change.

3.2.6 Use Pressure Sensor (Pressure Sensor)

The **Use Pressure Sensor** function allows the operator to enable the internal pressure sensor for depth measurements in both Discharge and General data collection modes.



Pressure sensor functions and associated software features are only available for FlowTracker2 ADV probes equipped with an internal pressure sensor.

3.2.7 Probe Offset From WR Bottom (Pressure Sensor)

The **Probe Offset From WR Bottom** functions allows the operator to enter an offset between the bottom of the ADV Probe and the wading rod base plate.



The ability to align the bottom of ADV Probe with the wading rod base plate will not be feasible for most wading rod designs. The Probe Offset From WR Bottom accounts for the difference between the bottom of ADV Probe and the wading rod base plate in the depth measurements.



It's recommended that the offset selected should exceed the average size of obstacles on the channel bed. If a two point method is performed during a measurement it is recommended that the offset should be equal to the average of all the 0.8 measurements to reduce adjustment time.

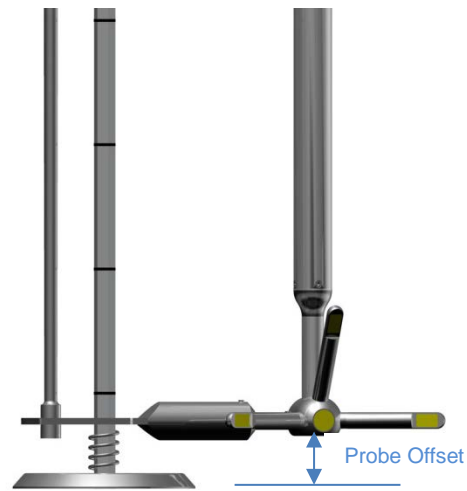

Figure 3:4 – Probe Offset From WR Bottom



The user can make use of the top setting rod vernier scale to reference the offset. Example, if the graduation mark '1' on the suspension rod is opposite the graduation "0" on the Vernier scale, it represents a 0.068 m (0.22 ft) offset.

3.2.8 Air Pressure Cal. Period (min) (Pressure Sensor)

The FlowTracker2 ADV internal pressure sensor can be calibrated against atmospheric pressure during any stage of the measurement. The **Air Pressure Cal. Period (min)** function allows the operator to set a time limit between atmospheric pressure calibrations.

Properties associated with the Air Pressure Cal. Period are defined in [Table 3:6](#),

Table 3-6 - Air Pressure Cal. Period - Properties

Parameter	Min	Max	Default	Units	Required
Air Pressure Cal.	5	60	10	minutes	Yes

Parameter	Min	Max	Default	Units	Required
Period					



If the period between calibrations is too long, the change in atmospheric pressure can impact the accuracy of the depth measurements

3.3. Configuration Templates

3.3.1 Template Options

The **Templates** implemented in FlowTracker2 consists of the following template options. The templates consist of number of configuration parameters required for performing measurements in either **Discharge** or **General** mode under the Measurement function.

- **Discharge** Template
- **General** Template

Templates are similar to configuration files where the operator defines the configuration of the instrument, based on,

- site details,
- data collection requirements
- quality control parameters,
- measurement methods (*only for discharge mode*).

The operator has the ability to create a unique configuration template for a single monitoring site, region or organization.



It's recommended that a unique template is created for each monitoring site. The advantage of this is twofold, operator does not have to enter in the site number and name for every measurement, and ensure that site number and name is consistent.

3.3.2 Managing Templates

3.3.2.1 Accessing Templates

Templates are stored separately from the measurement files on the internal memory of the FlowTracker2 handheld and are managed from the Discharge or General Template functions under the Device Configuration Menu. The following process describes how to create, remove or select an existing template.

Templates for Discharge and General Modes can be accessed from the Device Configuration menu,

- To *select* a Template type,
 - Use up or down scroll arrows keys to select the template,
 - The template option selected will be highlighted in yellow,
 - Press the enter key to access the template operating screen.
- To *navigate* to Main Menu,
 - Press the Left Soft Key.

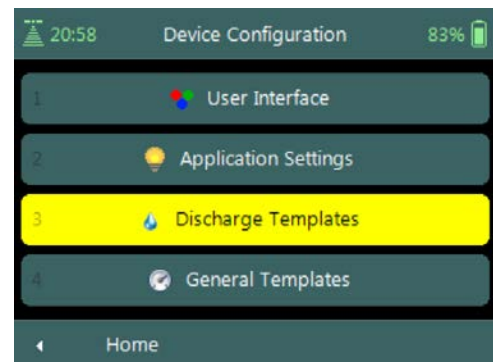

Figure 3:5 - Device Configuration Menu

Template Operating Screen will list all available templates on the handheld or if there are no templates available, indicate “Currently there are no user templates defined – please use the ‘New Template’ button to create the first template”.

- a) To **create** a new Template,
 - i). Press the Right Soft Key,
 - ii). The software will redirect to “New Template” screen.
- b) To **navigate** to Configuration Menu,
 - i). Press the Left Soft Key.

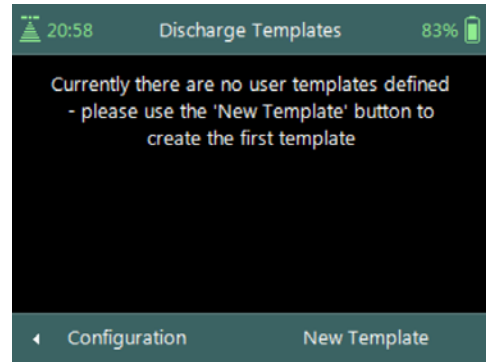

Figure 3:6 - Template Operating Screen

3.3.2.2 New Template

New Template screen displays two parameters that need to be completed to create a new template,

- a) **Template Name** is user defined. The template name can be up to 50 characters long.
- b) **Base Template** defines the default configuration used for new template. The user has the option to select the default SonTek configuration or from existing user configurations.
- c) To **accept** new Template,
 - i). Press the Right Soft Key,
 - ii). The software will return to template screen.
- d) To **CANCEL** new Template,
 - i). Press the Left Soft Key.

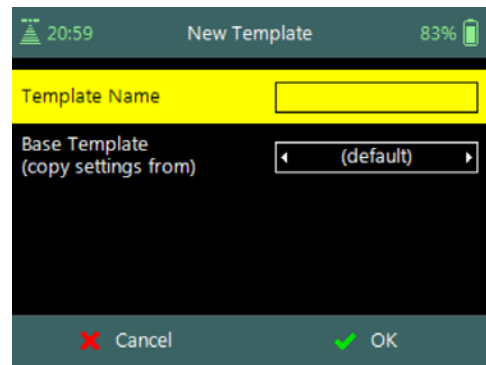

Figure 3:7 - New Template

3.3.2.3 Selecting Template

Selecting Template is performed from the template main screen.

- a) To **select** a Template,
 - i). Use up or down scroll arrows keys to select the template,
 - ii). The template name selected will be highlighted in yellow,
 - iii). Press the enter key to access the template screen.
- b) To **navigate** to Configuration or New Template,
 - i). Configuration - Press the Left Soft Key
 - ii). New Template - Press the Right Soft Key

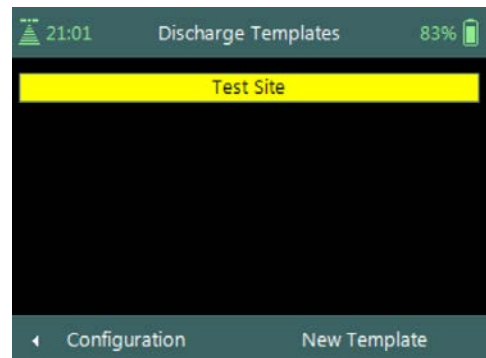

Figure 3:8 - Selecting Template

3.4. Template Functions

The **Template** functions for Discharge and General Modes contain all the configuration parameters required for performing velocity measurements, discharge calculation and uncertainty analysis. The functions defined under each template contain site information, data collection criteria, quality control parameters and measurement methods (*only for discharge mode*).

Template menu consists of the following menu options,

- a) File Properties,
- b) Data Collection Settings,
- c) Quality Control Settings,
- d) Discharge Settings (*only for discharge mode*),
- e) Displayed Velocity Methods (*only for discharge mode*).
- f) *To select a menu option,*
 - i). Use up or down scroll arrows keys to select menu option,
 - ii). The menu option selected will be highlighted in yellow,
 - iii). Press the enter key to access the menu option.
- g) *To navigate to Template Screen,*
 - i). Press the Left Soft Key.
- h) *To **Rename** or **DELETE** a Template in Menu,*
 - i). Press the Right Soft Key.
 - ii). To select menu option, use up or down scroll arrows keys,
 - iii). The menu option selected will be highlighted in yellow,
 - iv). Press the enter key to access the menu option.

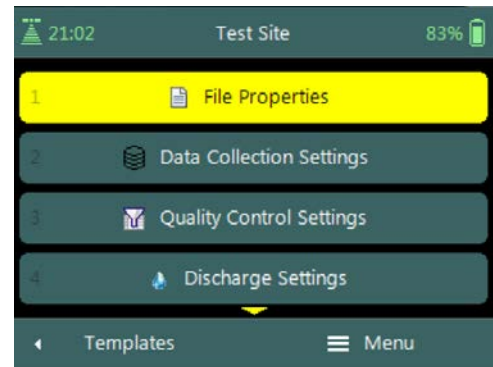

Figure 3:9 - Template Menu

3.4.1 File Properties

The **File Properties** function contains site information applicable to the measurement site and operator details. The file properties ensure that the required Metadata are associated with both measurement site and data collected.

File Properties screen includes the following parameters,

- a) Site Number,
- b) Site Name,
- c) Operator.
- d) *To select a parameter,*
 - i). Use up or down scroll arrows keys to select a parameter,
 - ii). The parameter selected will be highlighted in yellow.
- e) *To enter text,*
 - i). Use the backspace key to clear current entry,
 - ii). Enter numerical or alphabetical characters using the keypad.
- f) *To navigate to Template Menu,*
 - i). Press the Left Soft Key.

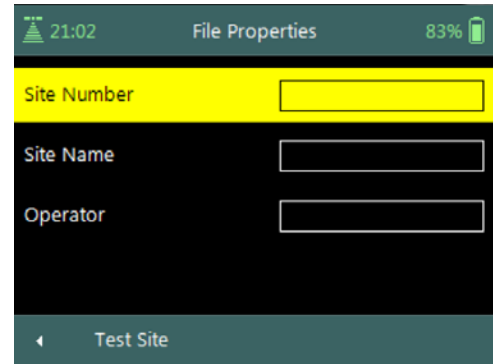

Figure 3:10 - File Properties

Properties associated with the parameters in file properties are defined in [Table 3:7](#),

Table 3-7 - File Properties - Properties

Parameter	Description	Field Size	Default	Required
Site Number	Enter unique site number (e.g. Hydrometric Station Number)	50	Number keypad	No
Site Name	Enter unique site name (e.g. Hydrometric Station Name)	50	Alphabet keypad	No
Operator	Operator name can be entered in this field (e.g. Bees Blaas)	50	Alphabet keypad	No

3.4.2 Data Collection Settings

The **Data Collection Settings** function contains parameters required for sound speed calculation and averaging time of velocity measurements,

Data Collection Settings screen includes the following parameters,

- a) Averaging Time,
- b) Salinity,
- c) Temperature,
- d) Sound Speed,
- e) Mounting Correction.
- f) *To select a parameter,*
 - i). Use up or down scroll arrows keys to select a parameter,
 - ii). The parameter selected will be highlighted in

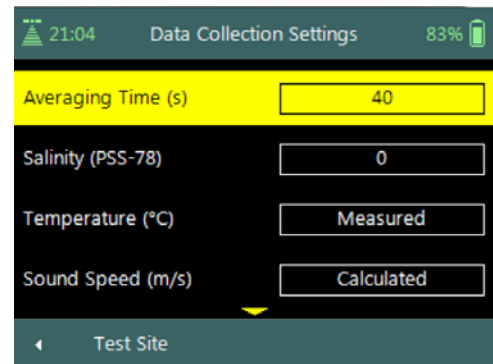

Figure 3:11 - Data Collection Settings

yellow.

- g) To *navigate to Template Menu*,
- i). Press the Left Soft Key.

Properties associated with the parameters in data collection settings are defined in [Table 3:8](#),

Table 3-8 - Data Collection Settings - Properties

Parameter	Min	Max	Default	Units	Required
Averaging Time	10	1000	40	seconds	Yes
Salinity	0	42	0	PSU	Yes
Temperature	-5	50	Internal Measured	°C or °F	Yes
Sound Speed	1400	1580	Internal Calculated	m/s or ft/s	Yes
Mounting Correction	-5	5	0	%	Yes

3.4.2.1 Averaging Time

The **Averaging Time** parameter specifies the time duration (in seconds) of data collection during each point velocity measurement.

- a) Averaging time is specified in 1-second intervals from 10 to 1000 seconds.
- b) The default Averaging Time applied in FlowTracker2 is 40s.
- c) To *change the Averaging Time*,
 - i). Use the backspace key to clear current entry,
 - ii). Type in the new value using the keypad.



The averaging time required for single point velocity measurement is usually from 40 to 60 seconds. This however is site dependent and longer averaging times are required when measuring in turbulent flow conditions.

3.4.2.2 Salinity

The **Salinity** parameter specifies the salinity value in **Practical Salinity Scale** (dimensionless) used to compute sound speed.

- a) Salinity is specified in Practical Salinity Scale (PSS-78). Fresh water has a salinity of 0; seawater salinity generally ranges from 31 to 39 (PSS). The PSS-78 range is 2 to 42 for a temperature range of -2°C to +35°C and hydrostatic pressure 0 – 10000dBar.
- b) The default Salinity applied in FlowTracker2 is 0 (PSS).



Where a measurement location exceeds the PSS-78 range, Salinity cannot be used for calculation of Sound Speed. **Sound Velocimeters** must be used to measure the actual sound speed of the water directly at the measurement location.

- c) As a rule of thumb, a 12 (PSS) error in the value of salinity will result in a 1% error in sound speed, which results in a 2% error in velocity data.

- d) Salinity should be specified or determined using a CTD instrument as accurately as possible for each measurement location. The **CastAway-CTD** is a lightweight, easy to use instrument designed for quick and accurate conductivity, temperature, and depth profiles. Starting with a unique six-electrode conductivity cell and fast response thermistor the CastAway makes use of modern technology to provide state of the art CTD measurements.



Figure 3:12 - CastAway - CTD

- e) Sound speed is used in Doppler velocity calculations. See the [Principle of Operations](#) for details about the effect of sound speed on velocity data.
- f) *To **change** the Salinity,*
- i). Use the backspace key to clear current entry,
 - ii). Type in the new value using the keypad.

3.4.2.3 Temperature

The **Temperature** parameter specifies the temperature value used to compute sound speed.

- a) The temperature value used to compute sound speed is based on internal temperature sensor by default. The temperature field will be populated with the value “**Measured**” to indicate it is based on internal temperature sensor.
- b) Water temperature measured by external devices can be entered in the temperature field. The temperature value from the external sensor will then be used for sound speed calculations.



The temperature field cannot be used to store reference temperature readings as this will be used in the sound speed calculations. It is recommended that reference temperature readings be documented in the comments fields.

- c) Sound speed is used in Doppler velocity calculations. See the [Principle of Operations](#) for details about the effect of sound speed on velocity data.
- d) ***Enter** external temperature reading,*
 - i). If the default value “Measured” is displayed, start typing using keypad, otherwise,
 - ii). Use the backspace key to clear current entry,
 - iii). Type in the new value using the keypad.

3.4.2.4 Sound Speed

The **Sound Speed** parameter specifies the sound speed value used in Doppler velocity calculations.

- a) The sound speed value used in Doppler velocity calculations is based on internal calculations by default. The sound speed field will be populated with the value “**Calculated**” to indicate it is based internal calculations.
- b) Sound Speed measured by external devices can be entered in the sound speed field. The sound speed value from the external sensor will then be used in Doppler velocity calculations.



Where a measurement location exceeds the PSS-78 range, Salinity cannot be used for calculation of Sound Speed. **Sound Velocimeters** must be used to measure the actual sound speed of the water directly at the measurement location.



The sound speed field cannot be used to store reference sound speed readings as this will be used in the Doppler velocity calculations. It is recommended that reference sound speed readings be documented in the comments fields.

- c) Sound speed is used in Doppler velocity calculations. See [Principle of Operations](#) for details about the effect of sound speed on velocity data.
- d) **Enter external Sound Speed reading**,
 - i). If the default value “Calculated” is displayed, start typing using keypad, otherwise,
 - ii). Use the backspace key to clear current entry,
 - iii). Type in the new value using the keypad.

3.4.2.5 Mounting Correction

The **Mounting Correction** parameter specifies how to account for the device used to hold the FlowTracker2 in the water. The type of mount may have a small impact on velocity measurements.

- a) The mounting correction allows the FlowTracker2 to account for the effect of flow disturbances caused by the mount.
- b) The default mounting correction applied in FlowTracker2 is 0%.
- c) The application of a mounting correction to account for the effects of flow disturbance on velocity measurements was researched by several independent agencies. At present, no consensus has been reached between different agencies in the requirement of the mounting correction. See [Mounting Correction](#) for details about the effect of flow disturbance on velocity measurements.
- d) **To change the Mounting Correction**,
 - i). Use the backspace key to clear current entry,
 - ii). Type in the new value using the keypad.

3.4.3 Quality Control Settings

The **Quality Control Settings** function contains parameters required for the Quality Control process.

Quality Control Settings screen includes the following parameters,

- a) SNR Threshold,
- b) Std Error Threshold,
- c) Spike Threshold,
- d) Velocity Angle for Warning,
- e) Tilt Angle Warning.
- f) *To select a parameter,*
 - i). Use up or down scroll arrows keys to select a parameter,
 - ii). The parameter selected will be highlighted in yellow.
- g) *To navigate to Template Menu,*
 - i). Press the Left Soft Key.

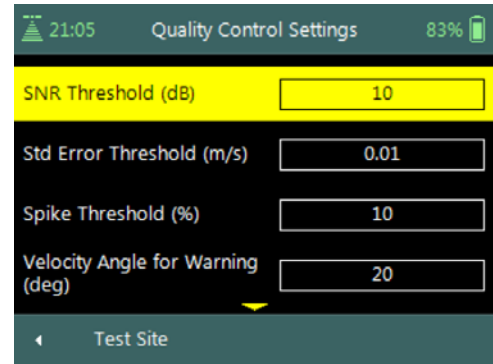

Figure 3:13 - Quality Control Settings

Properties associated with the parameters in quality control settings are defined in [Table 3:9](#),

Table 3-9 - Quality Control Settings - Properties

Parameter	Min	Max	Default	Units	Required
SNR Threshold	0	50	10	dB	Yes
Std Error Threshold	0.001	0.25	0.01	m/s or ft/s	Yes
Spike Threshold	0.01	50	10	%	Yes
Velocity Angle for Warning	0.1	90	20	degrees	Yes
Tilt Angle Warning	0.1	5	5	degrees	Yes

3.4.3.1 SNR Threshold

The **SNR Threshold** parameter is a minimum threshold placed on the SNR variable during real-time data collection.

- a) SNR is primarily a function of the amount of particulate matter in the water. For good conditions, SNR should be at least 10 dB.
- b) The system can operate effectively with SNR as low as 2-3 dB, although the noise in individual velocity measurements will increase.
- c) The default SNR Threshold applied in FlowTracker2 is 10dB.
- d) *To change the SNR Threshold,*
 - i). Use the backspace key to clear current entry,
 - ii). Type in the new value using the keypad.
- e) *To **DISABLE** the SNR Threshold,*
 - i). Use the backspace key to clear current entry until “Disabled” is displayed.

3.4.3.2 Std Error Threshold

The **Standard Error Threshold** parameter is a maximum threshold placed on the Standard Error of velocity measurements.

- a) Standard error of velocity (σ_V) is a direct measure of the accuracy of the mean velocity data.
- b) The default Standard Error Threshold applied in FlowTracker2 is 0.01m/s.
- c) *To **change** the Standard Error Threshold,*
 - i). Use the backspace key to clear current entry,
 - ii). Type in the new value using the keypad.
- d) *To **DISABLE** the Standard Error Threshold,*
 - i). Use the backspace key to clear current entry until “Disabled” is displayed.

3.4.3.3 Spike Threshold

The **Spike Threshold** parameter is the maximum threshold placed on the percentage of spikes within a measurement.

- a) Spikes in velocity data occur with any acoustic Doppler velocity sensor such as the FlowTracker. Spikes may have a variety of causes – large particles, air bubbles, or acoustic anomalies.
- b) The default Spike Threshold applied in FlowTracker2 is 10%.
- c) *To **change** the Spikes Threshold,*
 - i). Use the backspace key to clear current entry,
 - ii). Type in the new value using the keypad.
- d) *To **DISABLE** the Spikes Threshold,*
 - i). Use the backspace key to clear current entry until “Disabled” is displayed.

3.4.3.4 Velocity Angle for Warning

The **Velocity Angle for Warning** parameter is the maximum threshold placed on the velocity angle towards the probe.

- a) An angle of 0° means flow direction is perpendicular to the tag line (as desired for an ideal measurement location).
- b) The default Velocity Angle for Warning applied in FlowTracker2 is 20 degrees.
- c) *To **change** the Velocity Angle for Warning,*
 - i). Use the backspace key to clear current entry,
 - ii). Type in the new value using the keypad.
- d) *To **DISABLE** the Velocity Angle for Warning,*
 - i). Use the backspace key to clear current entry until “Disabled” is displayed.

3.4.3.5 Tilt Angle Warning

The **Tilt Angle Warning** parameter is the maximum threshold placed on the tilt angle of the wading rod.

- a) An angle of 0° means the wading rod is vertical (as desired for an ideal mounting position).
- b) The default Tilt Angle Warning applied in FlowTracker2 is 5 degrees.
- c) *To **change** the Tilt Angle Warning,*
 - i). Use the backspace key to clear current entry,
 - ii). Type in the new value using the keypad.
- d) *To **DISABLE** the Tilt Angle Warning,*
 - i). Use the backspace key to clear current entry until “Disabled” is displayed.

3.4.4 Discharge Settings

The **Discharge Settings** function contains parameters required for discharge calculations, discharge uncertainty analysis and quality control process.



Discharge settings function is only applicable to the Discharge Mode. The General Mode does not contain any discharge calculation or uncertainty analysis.

Discharge Settings screen includes the following parameters,

- a) Discharge Equation,
- b) Discharge Uncertainty,
- c) Discharge Reference,
- d) Max Station Q for Warning,
- e) Max Depth Change for Warning,
- f) Max Spacing Change for Warning.
- g) 0.6 Method Depth
- h) *To **select** a parameter,*
 - i). Use up or down scroll arrows keys to select a parameter,
 - ii). The parameter selected will be highlighted in yellow.
- i) *To **navigate** to Template Menu,*
 - i). Press the Left Soft Key.

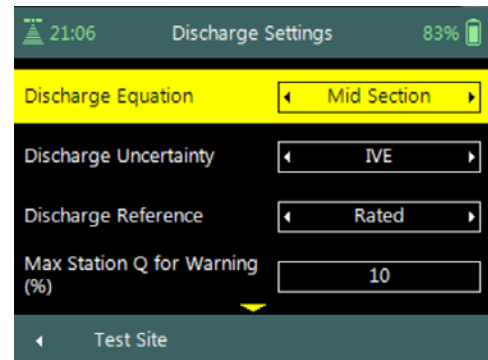

Figure 3:14 - Discharge Settings

Properties associated with the parameters in discharge settings are defined in [Table 3:10](#),

Table 3-10 - Discharge Settings - Properties

Parameter	Min	Max	Default	Units	Required
Max Station Q for Warning	0.01	100	10	%	Yes

Max Depth Change for Warning	0.01	200	50	%	Yes
Max Spacing Change for Warning	0.01	200	100	%	Yes
0.6 Method Depth	0	100	0.5	m or ft	Yes

3.4.4.1 Discharge Equation

The **Discharge Equation** parameter allows the user to specify what type of discharge calculation method must be applied in the discharge calculation process.

- a) The discharge equation calculation methods supported in FlowTracker2 software is grouped under the following,
 - i). Mid-Section Method,
 - ii). Mean-Section Method,
 - iii). Japanese Method.
- b) The default Discharge Equation applied in FlowTracker2 is Mid-Section.

The Arithmetic methods implemented for calculation of discharge are based on the following literature,



- ISO 748 – 2007, Hydrometry - Measurement of liquid flow in open channels using current meters or floats,
- WMO-No. 1044, Volume I – Fieldwork, 2010.
- Japanese Literature

- c) *To **change** the Discharge Equation method,*
 - i). Use the left or right arrow key to scroll through the list of options,

3.4.4.2 Discharge Uncertainty

The **Discharge Uncertainty** parameter allows the user to specify what type of uncertainty analysis must be applied in the discharge calculation process.

- a) The discharge uncertainty analysis supported in FlowTracker2 software is grouped under the following,
 - i). ISO 748 - 2007
 - ii). Interpolated Variance Estimator (IVE)
- b) The default Discharge Uncertainty method applied in FlowTracker2 is IVE.
- c) The discharge uncertainty analysis was not implemented for the Japanese discharge equation method.



The uncertainty analysis implemented for determining the overall discharge uncertainty are based on the following literature,

- ISO 748 – 2007, Hydrometry - Measurement of liquid flow in open channels using

current meters or floats,

- Cohn, T., Kiang, J., and Mason, R., Jr. (2013). "Estimating Discharge Measurement Uncertainty Using the Interpolated Variance.

d) To **change the Discharge Uncertainty method**,

- i). Use the left or right arrow key to scroll through the list of options,

3.4.4.3 Discharge Reference

The Discharge Reference parameter allows the user to specify what discharge should be used to determine the percentage discharge displayed at each station.

a) The discharge reference types supported for determine the percentage station discharge are the following,

- i). Rated Discharge
- ii). Measured Discharge

b) The default Discharge Reference applied in FlowTracker2 is Rated Discharge.

c) To **change the Discharge Reference**,

- i). Use the left or right arrow key to scroll through the list of options,

3.4.4.4 Max Station Q for Warning (%)

The **Max Station Q for Warning** parameter is the maximum threshold placed on station discharge.

a) Station discharge less than 5% of the total discharge is ideal; between 5 – 10% indicates that an additional station is required in the specific location, larger than 10% is not recommended.

b) The default Max Station Q for Warning applied in FlowTracker2 is 10%.

c) To **change the Max Station Q for Warning**,

- i). Use the backspace key to clear current entry,
- ii). Type in the new value using the keypad.

d) To **DISABLE** the Max Station Q for Warning,

- i). Use the backspace key to clear current entry until "Disabled" is displayed.

3.4.4.5 Max Depth Change for Warning (%)

The **Max Depth Change for Warning** parameter is the maximum threshold placed on depth change.

a) The change in depth between stations is evaluated to determine if depth may have been entered incorrectly.

b) The default Max Depth Change for Warning applied in FlowTracker2 is 50%.

c) To **change the Max Depth Change for Warning**,

- i). Use the backspace key to clear current entry,

- ii). Type in the new value using the keypad.
- d) To **DISABLE** the *Max Depth Change for Warning*,
 - i). Use the backspace key to clear current entry until “Disabled” is displayed.

3.4.4.6 Max Spacing Change for Warning (%)

The **Max Spacing Change for Warning** parameter is the maximum threshold placed on spacing change.

- a) The change in spacing between stations is evaluated to determine if depth was not entered incorrectly.
- b) The default Max Spacing Change for Warning applied in FlowTracker2 is 100%.
- c) To **change** the *Max Spacing Change for Warning*,
 - i). Use the backspace key to clear current entry,
 - ii). Type in the new value using the keypad.
- d) To **DISABLE** the *Max Spacing Change for Warning*,
 - i). Use the backspace key to clear current entry until “Disabled” is displayed.

3.4.4.7 0.6 Method Depth

The 0.6 Method Depth parameter is the threshold placed on the application of the six tenths velocity method.

- a) The six tenths velocity method is set as default method in the software when the measured depth is below the threshold specified.
- b) Different velocity method can be selected if the flow conditions are not suited for six tenths method.
- c) To **change** the *0.6 Method Depth*,
 - i). Use the backspace key to clear current entry,
 - ii). Type in the new value using the keypad.

3.4.5 Displayed Velocity Methods

The **Displayed Velocity Methods** function allows the user to specify which Discharge Velocity Methods must be displayed in the function.



Displayed Velocity Methods function is only applicable to the Discharge Mode. The General Mode does not contain any discharge calculation or uncertainty analysis.

Displayed Velocity Methods screen includes the following parameters,

- a) 0.2/0.8/0.6 Methods
- b) Kreps Methods
- c) 5-Point Methods
- d) 6-Point Methods
- e) Vertical Velocity Curve
- f) *To select a velocity method,*
 - i). Use up or down scroll arrows keys to select a parameter,
 - ii). The parameter selected will be highlighted in yellow.
- g) *To display a velocity method,*
 - i). Use the left or right arrow key to select either “Yes” or “No”
- h) *To navigate to Template Menu,*
 - i). Press the Left Soft Key.

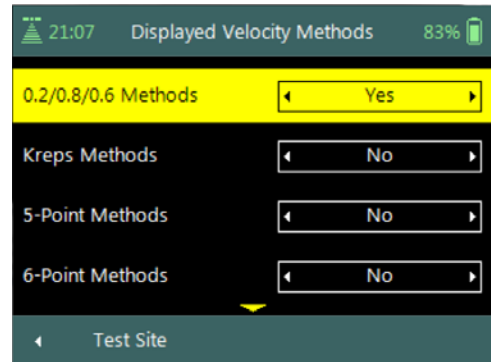

Figure 3:15 - Displayed Velocity Methods

Discharge Velocity Methods specifies how the FlowTracker2 determines mean station velocity at each station. See [Determining Mean Station Velocity](#) for details on the Discharge Velocity Methods. **Properties** associated with the parameters in displayed velocity methods are defined in [Table 3:11](#),

Table 3-11 - Displayed Velocity Methods - Properties

Discharge Velocity Method	Default Display	Required
0.2/0.8/0.6 Methods	Yes	At least one method is required for Discharge Mode
Kreps Methods	No	
5-Point Methods	No	
6-Point Methods	No	
Vertical Velocity Curve	No	

Methods implemented for determining mean velocity in a vertical are based on the following literature,



- ISO 748 – 2007, Hydrometry - Measurement of liquid flow in open channels using current meters or floats,
- WMO-No. 1044, Volume I – Fieldwork, 2010.

Section 4. Utilities

4.1. System Clock

System Clock function enables the setting of the internal date and time used in the FlowTracker2 handheld software. The main data collection processes are associated with internal date and time stamps and it is important that the instrument date and time are configured correctly.

System Clock screen includes the following parameters,

- a) Date,
- b) Time,
- c) UTC Time.
- d) To **change** internal date and time,
 - i). Press the Right Soft Key to select Menu,
 - ii). Use up or down scroll arrows keys to select an option,
 - iii). Press enter key to select the parameter highlighted in yellow.
- e) To **navigate** to Utilities menu,
 - i). Press the Left Soft Key.

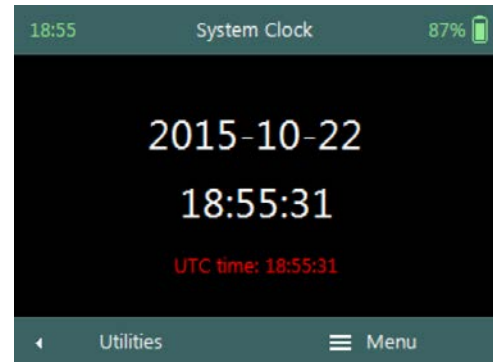

Figure 4:1 - System Clock

The System Clock options implemented to set the internal data and time of the FlowTracker2 handheld are the following,

- Manual Change
- Sync with GPS Time



Setting the correct date and time in the FlowTracker2 handheld is important to ensure that the correct metadata are associated with all measurements.

4.1.1 Manual Change

Manual Change option requires the user to enter the correct date and time based on external references.

Change System Clock screen includes the following parameters,

- a) Offset From UTC,
- b) Date,
- c) Time.
- d) To **select** a parameter,
 - i). Use up or down scroll arrows keys to select a parameter,
 - ii). The parameter selected will be highlighted in

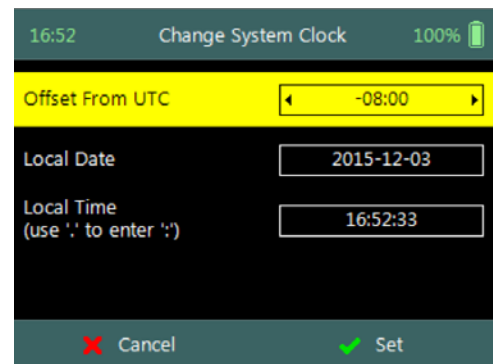

Figure 4:2 - Change System

yellow.

Clock

- e) To **change** the *Offset From UTC*,
 - i). Use the left or right arrow key to scroll through the list of available offsets,
 - ii). Type in the new value using the keypad.
- f) To **change** the *Date or Time*,
 - i). Use the backspace key to clear current entry,
 - ii). Type in the new value using the keypad.
- g) To **accept** the new *Date and Time settings*,
 - i). Press the Right Soft Key,
 - ii). The software will return to System Clock screen.
- h) To **CANCEL** change of *System Clock settings*,
 - i). Press the Left Soft Key.



The System Clock time is displayed on the left corner of the top banner of the LCD screen in hh:mm. The time displayed can be referenced against an external reference to determine if the instrument internal clock is correct.

The **Properties** associated with the date and time parameters for manual Change option are defined in [Table 4:1](#),

Table 4-1 - Date and Time - Properties

Parameter	Format	Separator	Example
Date	yyyy-mm-dd	-	2015-10-22
Time	hh:mm:ss	:	19:11:22
Offset From UTC	hh:mm	:	00:15

4.1.2 Sync with GPS Time

Sync with GPS Time option synchronizes the internal date and time of the FlowTracker2 handheld to GPS date and time.



When synchronizing the System Clock with GPS the internal time will be based on UTC time. Make sure the offset from UTC is set based on your region and select “Sync with GPS Time” again. The GPS time will now be correct with the offset from UTC time.

- a) The information displayed on **Sync with GPS Time** screen includes the following,
 - i). Waiting for GPS time.
- b) The date and time will be updated when there are sufficient satellites in view of the handheld to establish a GPS lock.
- c) *The software will Navigate to the System Clock screen when the synchronization is complete.*

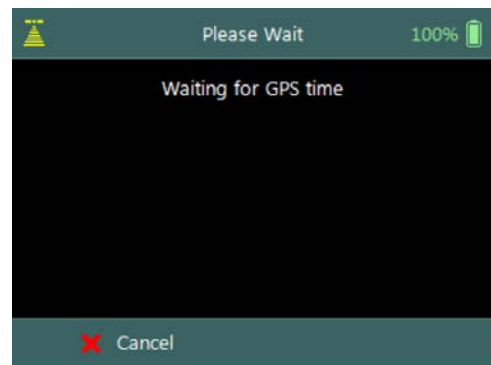

Figure 4:3 - Sync with GPS Time

d) To **CANCEL** Sync with GPS Time,

i). Press the Left Soft Key.



GPS On: If the internal clock is detected to be more than one minute off – the clock text will be displayed in red and blinking. If the time difference with internal clock is less than 1 minute – the clock will be green.

GPS off: If the time difference with internal clock is less than 1 minute – the clock will be green.



The **system clock** has an internal battery that will keep time for approximately 3 months without the handheld AA battery cartridge installed. If the system is stored for a similar or longer period of time, it will be necessary to check or change the time.

4.2. Recorder

Recorder function enables the user to manage the memory usage of the internal recorder in the FlowTracker2 handheld. The available memory of the internal recorder is dependent on the type, number and size of the files stored.

- a) The following information is displayed on the **Recorder** screen,
 - i). Pie chart showing percentage of free and used recorder space,
 - ii). Free Space in Megabytes (MB),
 - iii). Used Space in Megabytes (MB).
- b) The size of the internal recorder is 2000MB.
- c) To **ERASE** internal recorder,
 - i). Press the Right Soft Key to select Erase All.
- d) To **navigate** to Utilities menu,
 - i). Press the Left Soft Key.



Figure 4:4 - Recorder

4.2.1 Manage Recorder

The FlowTracker2 stores different file types in the internal recorder based on the measurement method selected, templates created, configuration, firmware upgrade or language translation. The **Properties** associated with the FlowTracker2 file types stored on the internal recorder are defined in [Table 4:2](#),

Table 4-2 - File Types - Properties

File	Type	Extension	Visible	Erase
Measurement File	Flow Tracker 2 Measurement File	.ft	Yes	Yes
Templates	Flow Tracker 2 Configuration	.ft_template	Yes	Yes

File	Type	Extension	Visible	Erase
	Template File			
Manual Beam Check	Flow Tracker 2 Beam Check File	.ft_beamcheck	Yes	Yes
Configuration	not relevant/not user exposed	.dat	No	No
Firmware	Flow Tracker 2 Firmware File	.ft_firmware	1) Uploaded from PC. 2) Not visible or accessible in HH by user.	No
Language	Flow Tracker 2 Localization File	.lang	1) Created and uploaded from PC. 2) Can be deleted in HH by pressing the Delete button while the language is selected.	No

The management of the internal recorder is important requirement to ensure that good data management practices are followed with regard to the following aspects,

- safe keeping of measurement files,
- discarding unwanted measurement files,
- available recorder space,
- removing hidden or corrupt files.



The internal recorder should not be used as the main storage device for safe keeping of measurement files. It is recommended that measurements are downloaded by the end of each day and a copy of the measurement files are stored on either a computer or USB flash drive.

4.2.2 Erase Recorder

The **Erase** function allows the user to erase all Measurement, Template and Manual Beam Check files that were stored on the internal recorder. See [Table 4.2](#) for file types that are impacted by the erase function.

- Erase Recorder** require the user to input confirmation code “123”.
- To **ERASE** internal recorder,
 - Enter the confirmation code using the keypad,
 - Press the Right Soft Key to confirm.
- To **CANCEL** Erase Recorder,
 - Press the Left Soft Key.

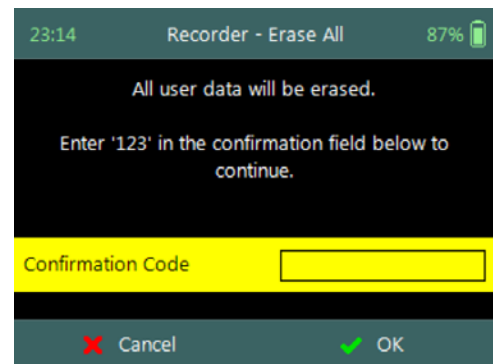

Figure 4:5 - Erase Recorder



Be certain that all data has been downloaded before erasing the recorder. Data cannot be recovered after the recorder is erased.



Regularly erasing the recorder ensures that good data management practices are followed. This will process will reduce the impact of unwanted or corrupt files on the available memory.

4.3. Battery Data

Battery Data function displays the battery voltage and estimated capacity of the battery used within the FlowTracker2 handheld.



The available battery capacity is displayed on the right corner of the top banner of the LCD screen as a percentage of the full capacity. The percentage available will guide the user in determining if batteries need to be replaced before a new measurement is started.

The **Battery Data** screen includes the following parameters,

- a) Battery Type,
- b) Battery Voltage,
- c) Percentage Full.
- d) To **change the Battery Type**,
 - i). Use the left or right arrow key to scroll through the list of available offsets.
- e) To **navigate to Utilities menu**,
 - i). Press the Left Soft Key.

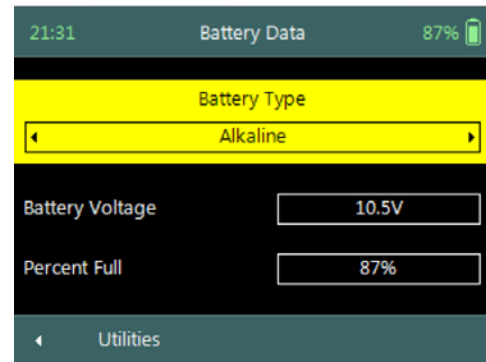

Figure 4:6 - Battery Data

4.3.1 Battery Type

The **Battery Type** parameter specifies the type of battery used within the FlowTracker2 handheld.

- a) The Battery Types supported in FlowTracker2 is grouped under the following,
 - i). Alkaline: 8 x size AA/LR6 Alkaline batteries,
 - ii). NiMH : 8 x size AA, Type BK200AAB, 1.2Vdc, 1900mAh



Only this type of NiMH rechargeable batteries with IEC 62133 approval can be used, or else safety protection will be void.



The use of NiMH Rechargeable Batteries is only CE certified per IEC 62133 for FlowTracker2 part number FT2-HH-2 and above.

- b) Battery specifications vary depending on brand. FlowTracker2 specifications are based on,
 - i). Alkaline: Energizer Industrial EN91,

- ii). NiMH: Panasonic Rechargeable BK200AAB,
 - iii). See also [Table 4:5 – Battery Specification](#).
- c) The typical capacity for battery types operating FlowTracker2 are the following. This is dependent on the brand of battery used and the environmental conditions that it is exposed to. **Battery capacity estimates are based on voltage and are only approximate, particularly for rechargeable batteries where voltage characteristics can change significantly over the life of the batteries.**
- i). 8 x size AA: ≈ 15 hours continuous use with typical settings.

The typical settings used for determining the battery capacity indicated above are based on the following,

- Operating screen at 100% brightness,
- ADV sensor pinging at 50% of the measurement time,
- No sleep periods,
- GPS off.



Cold weather can greatly affect battery voltage and capacity; always check battery voltage after the system has acclimated to outside temperatures.



Battery manufacturer guidelines must be followed during normal use, long term storage and charging requirements. The disposal of batteries must be done with care and it is recommended that local authority guidelines be used.

4.3.2 Battery Voltage

The **Battery Voltage** displayed is the current battery voltage level available from the batteries installed in the FlowTracker2 handheld.

4.3.3 Percentage Full

The **Percentage Full** is an estimate of the remaining capacity of the battery as a percentage of the full capacity.



When the remaining capacity of the battery reaches **0%**, the FlowTracker2 handheld will supply the following message, “*Battery level critically low – shutting down*”. The user will be required to replace the batteries before continuing with operations.

4.4. Raw Data Display

Raw Data function allows the graphical display of raw time series data measured by the FlowTracker2. The raw time series data are displayed with the units as shown below.

The **Raw Data** screen includes the following variables,

- a) Velocity,
- b) SNR,
- c) Temperature,
- d) Tilt,
- e) Battery,

Pressure Sensor f) Pressure.

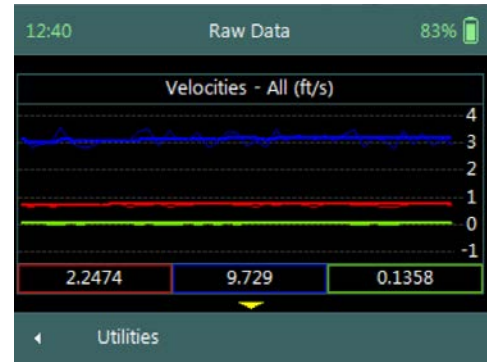

Figure 4:7 - Raw Data

- g) To *select* a variable,
 - i). Use up or down scroll arrows keys to view a variable.
- h) To *navigate* to Utilities menu,
 - i). Press the Left Soft Key.



Raw Data displayed in this function are NOT stored but enable the user to verify if the flow conditions are ideal for measurements.

4.4.1 Velocity Raw Data

The **Velocity** variable displays the individual velocity components of the one second measured raw velocity data.

- a) Velocity data can be expected to show notable variations (most of which are real), and should be indicative of the general conditions in the water,
- b) The raw velocity data are updated once per second,
- c) The FlowTracker2 Probe Coordinate System is outlined in [Figure 4:8](#).

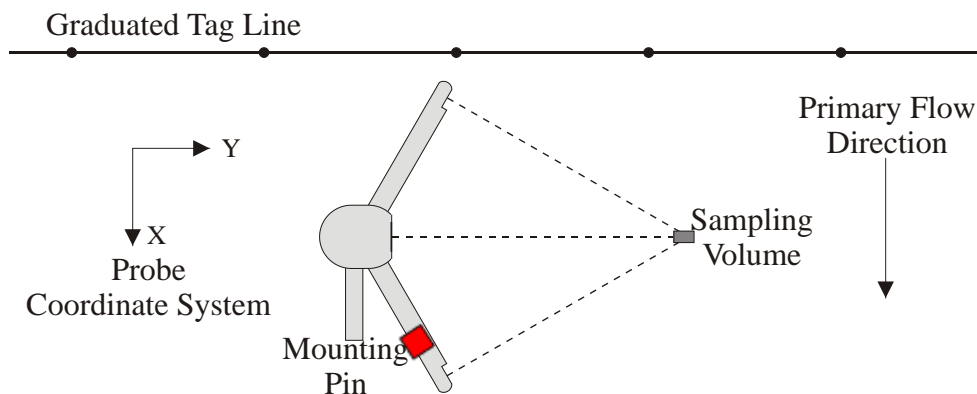
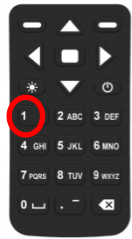
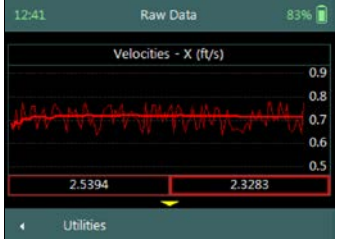

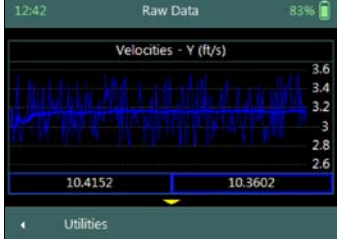

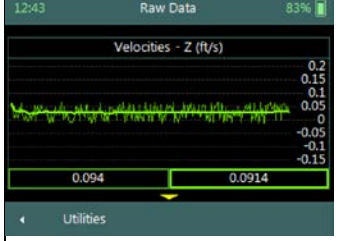
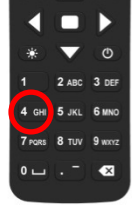
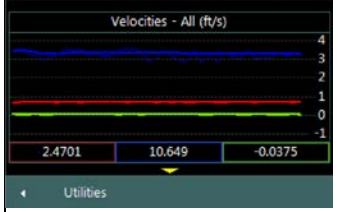

Figure 4:8 - FlowTracker2 Coordinate System

- d) The velocity components of FlowTracker2 and display options for individual or all velocity components are listed in [Table 4:3](#). The shortcut key on the keypad determines which velocity component will be displayed.

Table 4-3 - Raw Velocity Display

Velocity Component	Description	Line Color	Keypad Key	Graphic Display
X - Velocity	The positive X-axis is defined perpendicular to both the probe's stem and the axis of the transmit transducer in the direction of receiver arm #1 (marked with a red band).	Red		
Y - Velocity	The positive Y-axis is defined along the axis of the transmit transducer from the transmitter towards the sampling volume (making a right-handed coordinate system).	Blue		
Z - Velocity	The positive Z-axis is defined as vertically up in the direction of the probe's stem.	Green		
All Velocities	All of the above	Red / Blue / Green		

- e) The continuous lines displayed in the graphics are defined under the following categories,
 - i). **Thin** continuous line represents the one second raw velocity data,
 - ii). **Thick** continuous line represents moving average of the one second raw velocity data.
- f) The velocity values displayed in the rectangular boxes for each velocity component below the graphical display are defined under the following categories,
 - i). **Thin** box outline, instantaneous one second raw velocity data,
 - ii). **Thick** box outline, represents moving average of the one second raw velocity data.

4.4.2 SNR Raw Data

The **SNR** variable displays the individual Beam SNR measurements from the one second measured raw data.

- a) SNR is primarily a function of the amount of particulate matter in the water. For good conditions, SNR should be at least 10 dB. The system can operate effectively with SNR as low as 2-3 dB, although the noise in individual velocity measurements will increase,
- b) The SNR data is updated once per second,
- c) The display options for individual or all beam SNR values are listed in [Table 4:4](#). The shortcut key on the keypad determines which beam SNR will be displayed,

Table 4-4 - Beam SNR Display

Beam	SNR	Line Color	Keypad Key
Beam1	SNR1	Red	1
Beam2	SNR2	Blue	2
Beam3	SNR3	Green	3
All Beams	All SNR	All	4

- d) The continuous lines displayed in the graphics are defined under the following categories,
 - i). **Thin** continuous line represents the one second raw SNR data,
 - ii). **Thick** continuous line represents moving average of the one second raw SNR data.
- e) The SNR values displayed in the rectangular boxes for each beam below the graphical display are defined under the following categories,
 - i). **Thin** box outline, instantaneous one second raw SNR data,
 - ii). **Thick** box outline, represents moving average of the one second raw SNR data.

4.4.3 Temperature Raw Data

The **Temperature** variable displays the temperature measurements from the one second measured raw data.

- a) Temperature data are used for sound speed calculations and can affect velocity data.
- b) Check temperature data to be sure the values are reasonable for the environment.
- c) The Temperature data are updated once per second.

4.4.4 Tilt Raw Data

The **Tilt** variable displays the angle of the wading rod from the vertical based on one second measured raw data.

- a) The Tilt information is calculated from the internal pitch and roll sensor in the FlowTracker2 probe.
- b) The Pitch and Roll data is recorded once per second.

4.4.5 Battery Indicator

The **Battery** variable displays the real time battery voltage level of the batteries housed in the FlowTracker2 handheld.

- a) The FlowTracker2 uses eight AA batteries contained in a battery pack.
- b) Cold weather can greatly affect battery voltage and capacity; always check battery voltage after the system has acclimated to outside temperatures.
- c) The Battery data are updated once per second.
- d) Comparison of Battery types are listed in [Table 4:5](#)

Table 4-5 – Battery Specification

Category	Alkaline	NiMH
General description	Single use	Rechargeable
Nominal battery capacity (typical)	1500 mAh	1900mAh
New battery voltage	12V	11V
Drained battery voltage	8V	9V



When the remaining capacity of the battery reaches **0%**, the FlowTracker2 handheld will supply the following message, “*Battery level critically low – shutting down*”. The user will be required to replace the batteries before continuing with operations.

4.4.6 Pressure ([Pressure Sensor](#))

The **Pressure** variable displays the pressure measurements from the one second measured raw data.

- a) Pressure data are used for calculating the total water and point measurement depth from the water surface.
- b) Atmospheric or Air pressure calibration should be performed before and during a measurement to compensate for changes in atmospheric pressure during a measurement.
- c) Pressure data are updated once per second.



Pressure data will not be displayed if the probe is in air. The probe must be submerged in water. Pressure sensor data displayed in this function are NOT stored and enables the user to verify the pressure sensor operations.

4.5. Automated Beam Check

The **Automated Beam Check** function allows the user to perform a Beam Check in the region of the measurement section before data collection starts. The automated beam check perform a number of quality control checks on the data collected to determine if the flow conditions are suitable for discharge measurements.



The **Automated BeamCheck** procedure and data analysis is discussed in detail in [6.4 Automated Beam Check](#) of the manual. It is recommended that the user study this section to get a full understanding of the BeamCheck procedure.

The **Automated Beam Check** screen shows the steps involved in performing an automated beam check.

- a) The FlowTracker2 probe should be placed in the region of the measurement section in moving water such that the probe is submerged and well away from any underwater obstacles.
- b) The FlowTracker2 collects data for about 20 seconds.

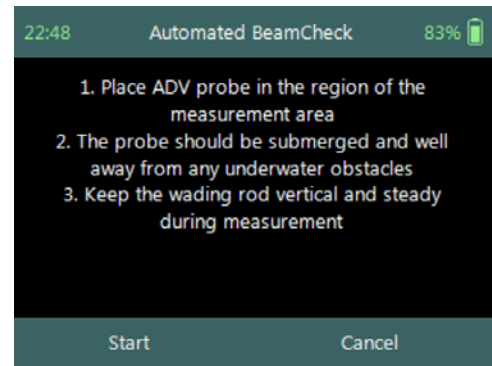

Figure 4:9 - Automated Beam Check

- c) The graphical display of the Quality Control parameters supplied during the Automated BeamCheck is time series of each parameter.
- d) The display options for individual or all beam check data are listed in [Table 4:6](#). The shortcut key on the keypad determines which beam SNR will be displayed,

Table 4-6 - Automated Beam Check Display

Beam	Line Color	Keypad Key
Beam1	Red	1
Beam2	Blue	2
Beam3	Green	3
All Beams	All	4

- e) *To select a Quality Control Criteria,*
 - i). Use up or down scroll arrows keys to view quality control criteria.
- f) *To start the automated beam check,*
 - i). Press the Left Soft Key.
- g) *To CANCEL automated beam check,*
 - i). Press the Right Soft Key,
 - ii). The software will navigate to Utilities window.
- h) *To accept Automated Beam Check,*

- i). Press the Right Soft Key,
- ii). The software will navigate to the Utilities window.

4.6. Beam Check

Beam Check operates by sending a pulse of sound into the water, and then plots the signal to noise ratio of the return signal versus range for each of the FlowTracker's receivers. This information can be evaluated to determine the effective measurement range, to look for interference from boundaries/structures, to survey a deployment site, or to observe the quality of the returned signal.



The **Beam Check** procedure and data analysis is discussed in detail in [6.3 Beam Check](#) of the manual. It is recommended that the user study this section to get a full understanding of the BeamCheck procedure.

- a) The Beam Check function can be accessed from the Utilities menu,
- b) Beam Check file will be recorded in the handheld recorder for each Beam Check performed. The file naming convention for beam check files consists of the following,
 - i). File Extension: .ft_beamcheck
 - ii). Naming Convention: yyyyymmdd-hhmmss
- c) The maximum number of samples that can be recorded during a Beam Check is 30.
- d) Place the probe in either a small tank, bucket of water or measurement section in canal or river such that the probe is submerged and there is a boundary (surface, side, or bottom) within view,
- e) *To record or stop recoding of Beam Check,*
 - i). Press the Right Soft Key,
- f) *To navigate to Utilities menu,*
 - i). Press the Left Soft Key.

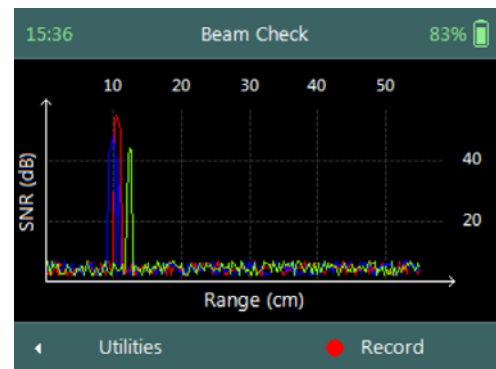

Figure 4:10 – Beam Check

4.7. GPS Data

GPS Data function display the Global Positioning System data received from the internal GPS receiver in the FlowTracker2 handheld. The GPS data displayed consist of satellite time, satellite information and coordinates.

The **GPS Data** screen includes the following variables,

- a) Device Date UTC,
 - b) Device Time UTC,
 - c) Satellite Date UTC,
 - d) Satellite Time UTC,
 - e) # Satellites,
 - f) Fix Quality,
 - g) Latitude,
 - h) Longitude,
 - i) Altitude,
 - j) HDOP.
- k) *To navigate to Utilities menu,*
- i). Press the Left Soft Key.

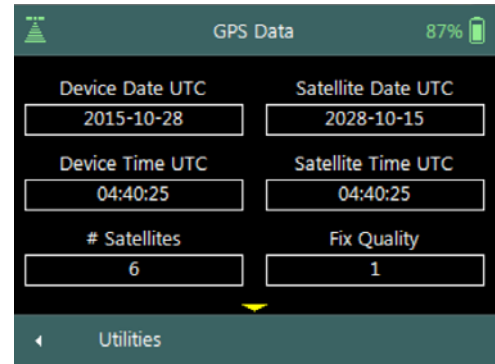

Figure 4:11 - GPS Data

Properties associated with the variables in displayed GPS Data screen are defined in [Table 4:7](#),

Table 4-7 - GPS Data - Properties

Variable	Description	Format \ Units
Device Date UTC	The FlowTracker2 handheld internal date set to Coordinated Universal Time (UTC).	yyyy-mm-dd
Device Time UTC	The FlowTracker2 handheld internal time set to Coordinated Universal Time (UTC).	hh:mm:ss
Satellite Date UTC	Current satellite date based on Coordinated Universal Time (UTC).	yyyy-mm-dd
Satellite Time UTC	Current satellite time based on Coordinated Universal Time (UTC).	hh:mm:ss
# Satellites	Number of satellites in view of GPS receiver in the FlowTracker2 handheld	n/a
Fix Quality	GPS Quality indicator (0=no fix, 1=GPS fix, 2=Dif. GPS fix)	n/a
Latitude	GPS derived Latitude	DDD° MM' SS.SS
Longitude	GPS derived Longitude	DDD° MM' SS.SS
Altitude	GPS derived altitude above mean sea level.	m
HDOP	Horizontal dilution of position is a GPS term used to describe the geometric strength of satellite configuration on GPS accuracy. HDOP values are typically between 1 and 2 although the ideal is a HDOP value of 1.	n/a

4.8. Pressure Sensor [\(Pressure Sensor\)](#)

Pressure Sensor function allows the user to perform individual measurement steps associated with pressure sensor during a Discharge or General measurement.



Depth data will not be displayed if the probe is in air. The probe must be submerged in water. Pressure Sensor Data displayed in this function are NOT stored. It enables the user to verify the pressure sensor operation and determine if flow conditions are ideal for measurements.

The **Pressure Sensor** screen includes the following features,

- a) PS Calibration,
- b) PS Instrument Depth,
- c) PS Total Depth,
- d) PS Charts.
- e) *To navigate to Utilities menu,*
 - i). Press the Left Soft Key.

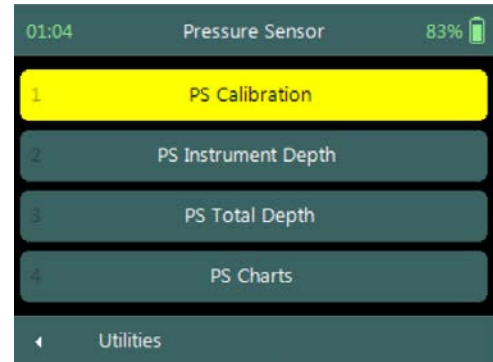

Figure 4:12 – Pressure Sensor

4.9. System Maintenance

System Maintenance function enables the user to perform number of maintenance tasks on the FlowTracker2 handled and probe firmware.

System Maintenance screen includes the following functions,

- a) Force Probe Upgrade,
- b) *To select a variable,*
 - i). Use up or down scroll arrows keys to view a variable.
- c) *To navigate to Utilities menu,*
 - i). Press the Left Soft Key.

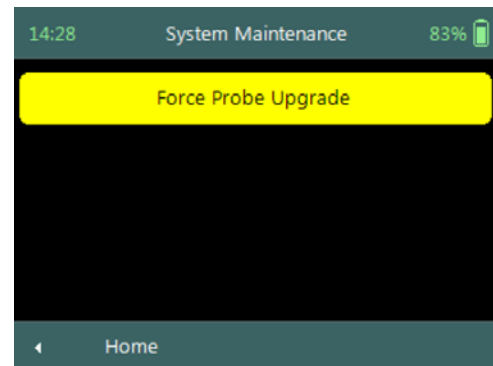

Figure 4:13 – System Maintenance

4.9.1 Force Probe Upgrade

The **Force Probe Upgrade** function allows the user to either upload or downgrade the firmware on the probe. This function is normally used when communication problems are experienced with the probe or when the probe firmware needs to be downgraded.

Warning screen of **Force Probe Upgrade** function displays the warnings associated with downgrading probe firmware,

- a) To **CANCEL** force probe upgrade,
 - i). Press the Left Soft Key.
- b) To **continue** with force probe upgrade,
 - i). Press the Right Soft Key.

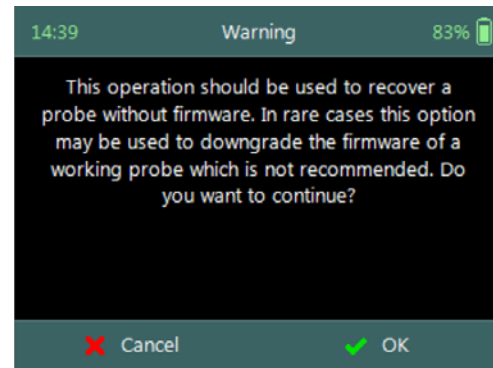

Figure 4:14 – Force Probe Upgrade Warning



In case where the probe firmware version is newer than the firmware installed on the handheld, the handheld will supply a warning message before each velocity measurement is performed: “The Probe firmware is newer than expected – please consider upgrading the Handheld firmware to the latest version available”

Section 5. Data Collection Modes

The FlowTracker2 provides two data collection modes that the user can apply in the collection of velocity data. The Discharge and General modes available in FlowTracker2 has different field applications and the method of each mode is described in this section.

5.1. Discharge Mode

Discharge Mode is for applications where the primary goal is to measure river/stream discharge. The technique involves taking a series of velocity measurements at different locations throughout the cross section. These measurements are combined with location and water depth information to compute the total discharge.

5.1.1 Measurement Technique

The basic **Measurement Technique** used for performing discharge measurement using the Discharge Mode is briefly discussed under the following points and this measurement process should be read in conjunction with [Site Selection Requirements](#).

- a) A measurement site is selected based on criteria stipulated in [Site Selection Requirements](#). The site selection process is a crucial part of collecting discharge measurement data.
 - i). Ideal measurement site, the flow should be perpendicular to the tag line at all points with no flow reversals or obstructions.
 - ii). The measurement site should encompass the minimum measurement site and hydraulic requirements discussed in [Site Selection Requirements](#).
 - iii). Flow conditions at the measurement site are the most important factor in determining overall accuracy of the measurement.
- b) A graduated tag line is strung across the river.
- c) The operator starts at one edge, recording the starting-edge location and water depth.
- d) The river cross section is split into several stations. At each station, the operator records the station location and water depth, and then performs velocity measurements at one or more depths to determine the mean velocity at that station.
- e) During velocity measurements, the probe's X-axis is maintained perpendicular to the tag line ([Figure 5:1](#)); the red band (receiver arm #1) should face downstream. Only the X-component of velocity (v_x) is used to in the discharge calculation, regardless of the flow direction (flow direction is also measured and recorded).

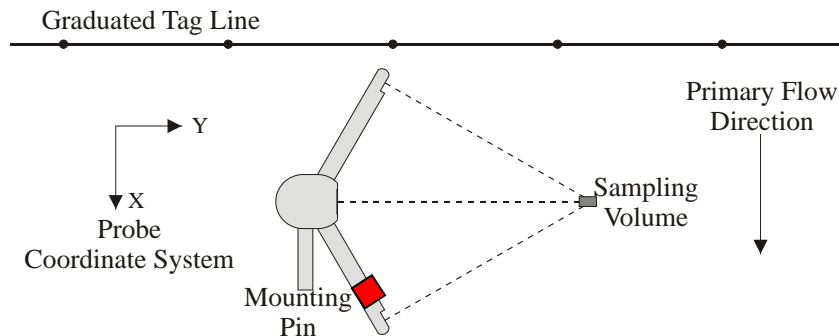

Figure 5:1 – FlowTracker2 Probe Orientation Relative to Stream Flow

- f) When all station measurements are completed, the operator records the ending-edge location and water depth.
- g) The total discharge is the sum of all station discharge values.

5.1.2 Discharge Calculation Methods

The discharge calculation methods implemented in FlowTracker2 are based on established methods that are documented in international standards and are widely used by government agencies, hydrologists and hydrographers. The discharge calculation methods were originally developed for current meter instruments. The FlowTracker2 makes use of the same measuring technique and for this reason the same calculation methods can be used to determine the total discharge.

The methods implemented for calculation of discharge are based on the following literature,



- ISO 748 – 2007, Hydrometry - Measurement of liquid flow in open channels using current meters or floats,
- WMO-No. 1044, Volume I – Fieldwork, 2010.
- Japanese Literature

The FlowTracker2 supports several discharge calculating methods for calculating discharge following the basic measuring technique outlined above.

- **Mid-Section** equation (see [5.1.2.1](#)),
- **Mean-Section** equation (see [5.1.2.2](#)),
- The **Japanese** equation (see [5.1.2.3](#)).

5.1.2.1 Mid-Section Equation

The **Mid-Section** method is based on a measurement section that is divided into a number of stations with panels created for each station across the section. The average velocity of a panel is assumed to be equal to the average velocity in the vertical calculated from the point velocity measurements made. The equation of the Mid-Section method is given in [Equation 5:1](#).



This method is used by the U.S. Geological Survey (USGS), the primary U.S. government agency responsible for river discharge monitoring.

Equation 5:1 - Mid-Section Method

$$Q = \sum \bar{v}_0 d_0 \left(\frac{b_1 - b_0}{2} \right) + \bar{v}_1 d_1 \left(\frac{b_2 - b_0}{2} \right) + \bar{v}_n d_n \left(\frac{b_{n+1} - b_{n-1}}{2} \right)$$

Edge	Open water	Open Water
------	------------	------------

where, \bar{v} is the average velocity in the vertical or at the station,
 d is the water depth measured at the station,
 b is the location of the station.

The application of the Mid-Section equation within a measurement section is graphically shown in [Figure 5:2](#). The principle of the Mid-Section method is highlighted in the figure below where the panel width (W_2) is calculated based on the station locations (L_2) with the station as the center of the panel.

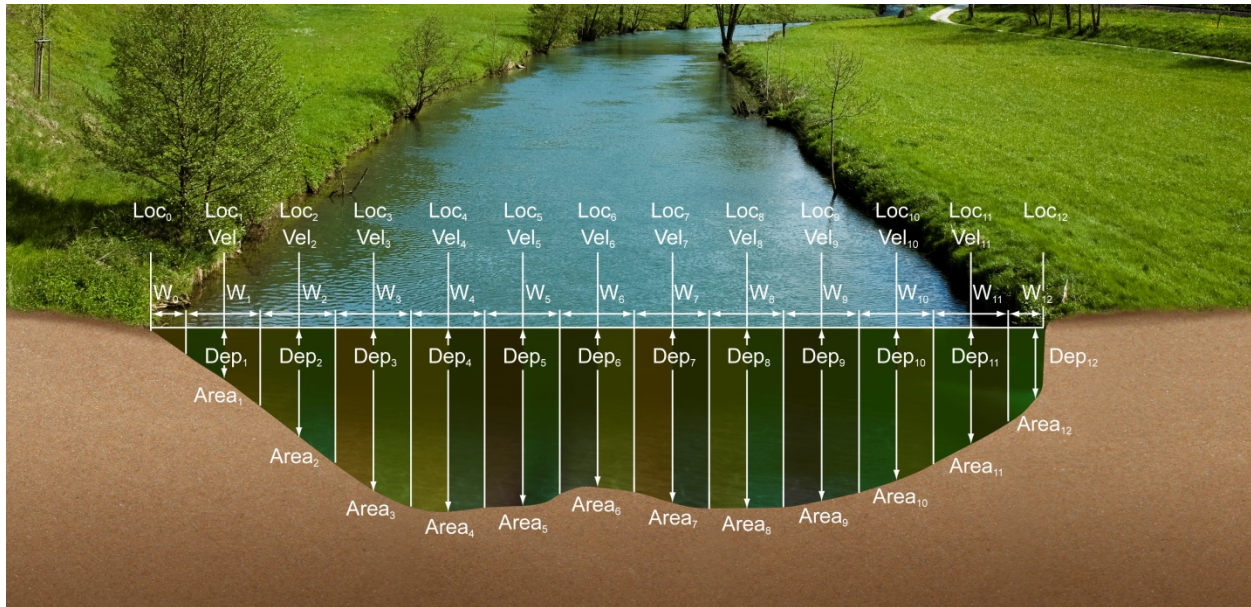

Figure 5:2 - Mid-Section Method

There are few special cases to consider when applying the Mid-Section method in calculating of total discharge.

a) Edges

- i). Edge can be either the Left Bank or Right Bank,
- ii). Edge calculations are handled differently from stations in open water with reference to the first component of [Equation 5:1](#),
- iii). The mean velocity at the edge is scaled from the adjacent station by a user defined correction factor (CF),
- iv). Edge water depth of zero will result in zero flow for the edge calculation.

b) **Islands** (multiple channels)

- i). If a river is split into multiple channels, any internal island(s) must be accounted for in the discharge calculation,
- ii). The stations at each edge of the island(s) are treated as an Island Edge,
- iii). Island edge calculations are handled the same as 71 with reference to the first component of Equation 5:1,
- iv). The mean velocity at the island edge is scaled from the adjacent station by a user defined correction factor (CF),
- v). Edge water depth of zero will result in zero flow for the edge calculation.

5.1.2.2 Mean-Section Equation

The **Mean-Section** method is based on a measurement section that is divided into number of stations with panels created in between adjacent stations across the section. The average velocity of a panel is assumed to be the average velocity of the two adjacent stations velocities in the vertical calculated from point velocity measurements made. The equation of the Mean-Section method is given in Equation 5:2.

Equation 5:2 - Mean-Section Method

$$Q = \sum (b_1 - b_0) \left(\frac{d_1 + d_0}{2} \right) \left(\frac{\bar{v}_1 + \bar{v}_0}{2} \right) + (b_2 - b_1) \left(\frac{d_2 + d_1}{2} \right) \left(\frac{\bar{v}_2 + \bar{v}_1}{2} \right) + (b_{n+1} - b_n) \left(\frac{d_{n+1} + d_n}{2} \right) \left(\frac{\bar{v}_{n+1} + \bar{v}_n}{2} \right)$$

Edge	Open water	Open Water
------	------------	------------

where, \bar{v} is the average velocity in the vertical or at the station,
 d is the water depth measured at the station,
 b is the location of the station.

The application of the Mean-Section equation within a measurement section is graphically shown in Figure 5:3. The principle of the Mean-Section method is shown in the figure below where panel width (W) is calculated based on the station locations between adjacent stations across the section.

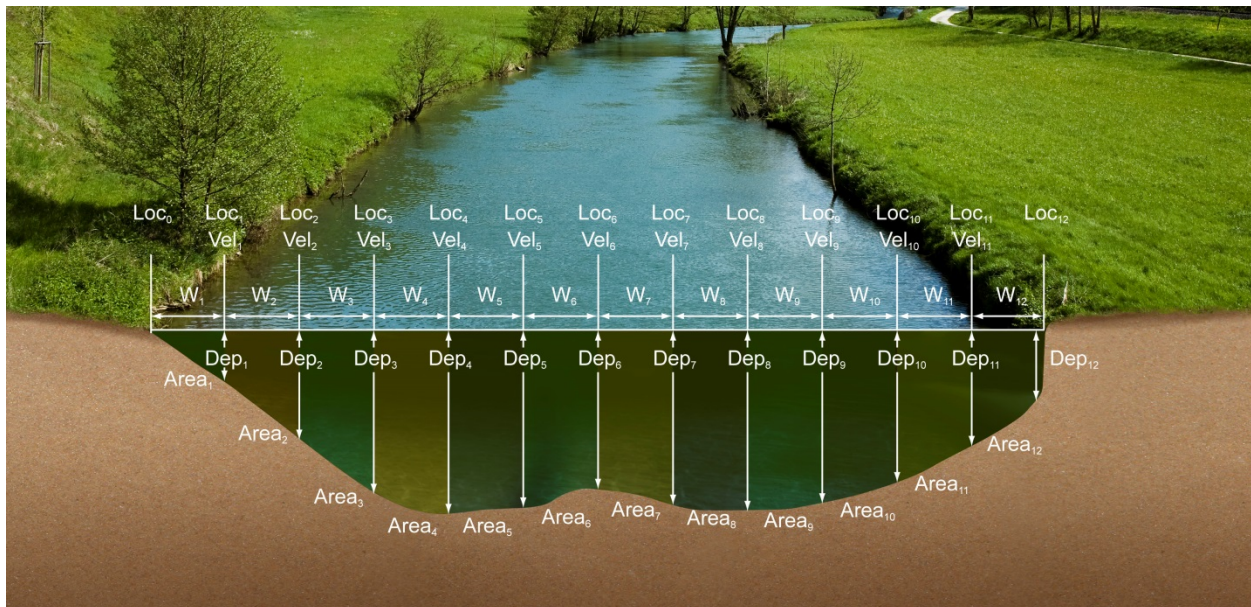

Figure 5:3 - Mean-Section Method

There are few special cases to consider when applying the Mean-Section method in calculating of total discharge.

a) **Edges**

- i). Edge can be either the Left Bank or Right Bank,
- ii). Edge calculations are handled exactly the same from stations in open water with reference to the first component of [Equation 5:2](#),
- iii). Correction factor (CF) is NOT applied in Mean-Section method to scale the mean velocity at the edges from the adjacent station,
- iv). The discharge on the edges can be determined by applying [Equation 5:2](#) on the assumption that the velocity at the edges is zero.

b) **Islands** (multiple channels)

- i). If a river is split into multiple channels, any internal island(s) must be accounted for in the discharge calculation,
- ii). The stations at each edge of the island(s) are treated as an Island Edge,
- iii). Island edge calculations are handled the same as [73](#) with reference to the first component of [Equation 5:2](#),
- iv). Correction factor (CF) is NOT applied in Mean-Section method to scale the mean velocity at the edges from the adjacent station,
- v). The discharge on the edges can be determined by applying [Equation 5:2](#) on the assumption that the velocity at the edges is zero.

5.1.2.3 Japanese Equation

The **Japanese** method is similar to both the Mean-Section and Mid-Section methods in some respects with its own unique measuring technique. The most significant feature of

the Japanese method is the duplicate measurements performed of each depth and point velocity measurements at a station. The Japanese national standard guideline for determining the measurement interval for depth and velocity are dependent on the measurement section width and are supplied in [Table 5:1](#).

Table 5-1 - Predetermination of Measuring Intervals

River Width, B (m)	Measuring Interval of Depth, M (m)	Measuring Interval of Velocity, N (m)
Less than 10m	10 – 15% of B	N=M
10-20	1	2
20-40	2	4
40-60	3	6
60-80	4	8
80-100	5	10
100-150	6	12
150-200	10	20
200 over	15	30

The Japanese method has two separate equations for determining the total discharge based on the measurement section width. The equation of the Japanese method for measurement section greater than 10m is given in [Equation 5:3](#).

Equation 5:3 - Japanese Method > 10m

$$Q = \sum \left\{ \left[(b_1 - b_0) \times 0.5 \left(\frac{d_1+d'_1}{2} + \frac{d_0+d'_0}{2} \right) + (b_2 - b_1) \times 0.5 \left(\frac{d_2+d'_2}{2} + \frac{d_1+d'_1}{2} \right) \right] \times \left(\frac{\bar{v}_1+\bar{v}'_1}{2} \right) \right\} +$$

Edge

$$\left\{ \left[(b_n - b_{n-1}) \times 0.5 \left(\frac{d_n+d'_n}{2} + \frac{d_{n-1}+d'_{n-1}}{2} \right) + (b_{n+1} - b_n) \times 0.5 \left(\frac{d_{n+1}+d'_{n+1}}{2} + \frac{d_n+d'_n}{2} \right) \right] \times \left(\frac{\bar{v}_n+\bar{v}'_n}{2} \right) \right\}$$

Open Water

The equation of the Japanese method for measurement section smaller than 10m is given in [Equation 5:4](#).

Equation 5:4 - Japanese Method < 10m

$$Q = \sum \left\{ \left[(b_1 - b_0) \times 0.5 \left(\frac{d_1+d'_1}{2} + \frac{d_0+d'_0}{2} \right) + \left(\frac{b_2-b_1}{2} \right) \times 0.5 \left(\frac{d_2+d'_2}{2} + \frac{d_1+d'_1}{2} \right) \right] \times \left(\frac{\bar{v}_1+\bar{v}'_1}{2} \right) \right\} +$$

Edge

$$\left\{ \left[\left(\frac{b_2-b_1}{2} \right) \times 0.5 \left(\frac{d_2+d'_2}{2} + \frac{d_1+d'_1}{2} \right) + \left(\frac{b_3-b_2}{2} \right) \times 0.5 \left(\frac{d_3+d'_3}{2} + \frac{d_2+d'_2}{2} \right) \right] \times \left(\frac{\bar{v}_2+\bar{v}'_2}{2} \right) \right\} +$$

Open Water

$$\left\{ \left[\left(\frac{b_n-b_{n-1}}{2} \right) \times 0.5 \left(\frac{d_n+d'_n}{2} + \frac{d_{n-1}+d'_{n-1}}{2} \right) + \left(\frac{b_{n+1}-b_n}{2} \right) \times 0.5 \left(\frac{d_{n+1}+d'_{n+1}}{2} + \frac{d_n+d'_n}{2} \right) \right] \times \left(\frac{\bar{v}_n+\bar{v}'_n}{2} \right) \right\}$$

Open Water

The application of the Japanese equation within a measurement section that is greater than 10m is graphically shown in [Figure 5:4](#).

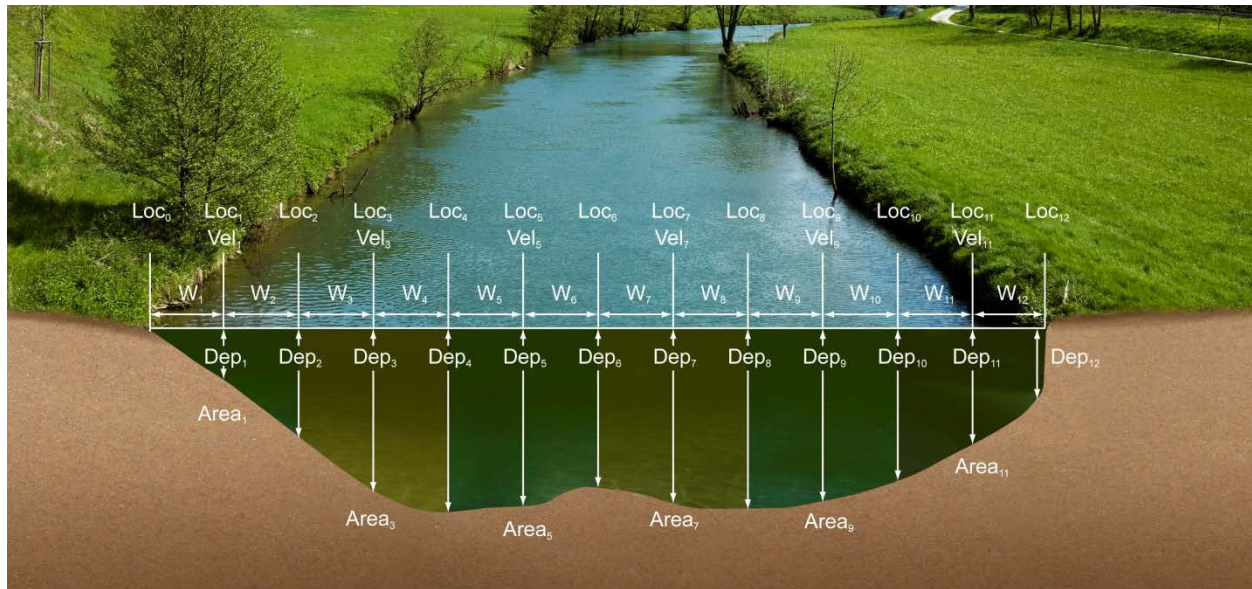

Figure 5:4 - Japanese Method >10m

There are few special cases to consider when applying the Japanese method in calculating of total discharge.

a) Edges

- i). Edge can be either the Left Bank or Right Bank,
- ii). Edge calculations are handled exactly the same from stations in open water with reference to the first component of [Equation 5:3](#),
- iii). Correction factor (CF) is NOT applied in Japanese method to scale the mean velocity at the edges from the adjacent station,

b) Islands (multiple channels)

- i). If a river is split into multiple channels, any internal island(s) must be accounted for in the discharge calculation,
- ii). The stations at each edge of the island(s) are treated as an Island Edge,
- iii). Island edge calculations are handled the same as [75](#) with reference to the first component of [Equation 5:3](#),
- iv). Correction factor (CF) is NOT applied in Japanese method to scale the mean velocity at the edges from the adjacent station,

5.1.3 Determining Mean Station Velocity

The **Mean Station Velocity** or **Mean Velocity in a Vertical** determines how mean velocity is determined at each station. The measurement techniques used involves variations in the number of point velocity measurements taken at a range of

measurement depths. The method used to calculate the mean velocity in a vertical depends on the number of point velocity measurements made within a vertical.

Methods implemented for determining mean station velocity in a vertical are based on the following literature,



- ISO 748 – 2007, Hydrometry - Measurement of liquid flow in open channels using current meters or floats,
- WMO-No. 1044, Volume I – Fieldwork, 2010.

The methods implemented in FlowTracker2 for determining the Mean Station Velocity are defined in [Table 5:2](#).

Table 5-2 - Determining Mean Station Velocity

Method	Measurement Depth	Mean Velocity Equation
0.6	0.6 * depth	$V_{\text{mean}} = CF * V_{0.6}$
0.2/0.8 0.8/0.2	0.2 * depth 0.8 * depth	$V_{\text{mean}} = CF * ((V_{0.2} + V_{0.8}) / 2)$
.2/.6/.8 .8/.6/.2	0.2 * depth 0.6 * depth 0.8 * depth	$V_{\text{mean}} = CF * ((V_{0.2} + 2*V_{0.6} + V_{0.8}) / 4)$
Ice 0.6	0.6 * effective depth	$V_{\text{mean}} = 0.92*V_{0.6}$ (Correction Factor 0.92 can be changed by user)
Ice 0.5	0.5 * effective depth	$V_{\text{mean}} = 0.88*V_{0.5}$ (Correction Factor 0.88 can be changed by user)
Ice 2/8 Ice 8/2	0.2 * effective depth 0.8 * effective depth	$V_{\text{mean}} = CF * ((V_{0.2} + V_{0.8}) / 2)$
Kreps 2- Kreps 2+	0.0 (near surface) 0.62 * depth	$V_{\text{mean}} = CF * (0.31*V_{0.0} + 0.634*V_{0.62})$
5 Point+ 5 Point-	0.0 (near surface) 0.2 * depth 0.6 * depth 0.8 * depth 1.0 (near bottom)	$V_{\text{mean}} = CF * ((V_{0.0} + 3*V_{0.2} + 3*V_{0.6} + 2*V_{0.8} + V_{1.0}) / 10)$
6 Point+ 6 Point-	0.0 (near surface) 0.2 * depth 0.4 * depth 0.6 * depth 0.8 * depth 1.0 (near bottom)	$V_{\text{mean}} = CF * ((V_{0.0} + 2*V_{0.2} + 2*V_{0.4} + 2*V_{0.6} + 2*V_{0.8} + V_{1.0}) / 10)$
Vertical Velocity Curve	Any number of points at user-specified depths	$V_{\text{mean}} = CF * \text{Integrated velocity}$ Measurements can be made in any order; they are sorted by depth to calculate the integrated mean velocity. Repeat measurements at the same depth are averaged prior to calculating the integrated velocity.

Method	Measurement Depth	Mean Velocity Equation
None	No velocity measurement	$V_{\text{mean}} = CF * V_{\text{adjacent}}$ Mean velocity is based on the velocity from the adjacent station(s), multiplied by a user-specified correction factor. This method is used when velocity measurements cannot be made or with the Japanese method.
Input V	User input velocity	$V_{\text{mean}} = V_{\text{input}}$ User enters an estimated velocity value. This method is used when velocity measurement is not possible, most commonly due to weed growth along a riverbank.



Methods involving more than one measurement can be done in either direction (from surface to the bottom or from the bottom towards the surface).

5.1.3.1 Method None

The method **None** is used in a number of different scenarios from assigning zero velocity to channel banks, stations where no measurements are possible to Japanese method where the measurement section is wider than 10m.

a) Channel Banks

- i). Edges describing the left or Right bank of a channel,
- ii). Island Edges describing the banks of island's,
- iii). The method **None** is assigned automatically for Edges and Island Edges by the software.

b) Station Measurement not Possible

- i). The measuring site conditions do not allow velocity measurement (perhaps due to weed growth),
- ii). Velocity for this station is based on the mean station velocity from the adjacent station(s) with velocity measurements multiplied by the user-specified correction (**CF**) factor for this station.

c) Japanese Method

- i). Japanese measuring technique for measurement sections wider than 10m require velocity measurements only at every second station,
- ii). A velocity method of “Depth Only” is assigned to **None** velocity stations.

5.1.3.2 Vertical Velocity Curve

The **Vertical Velocity Curve** method is a series of point velocity measurements that are well distributed between the water surface and channel bed. Normally observation is made at 0.1 depth increments between 0.1 and 0.9 of the total water depth. Point velocity measurements at the standard 0.2, 0.6 and 0.8 depths are required to compare the vertical velocity curve method against standard methods.

- a) For each measurement, you must manually enter the measurement depth.
- b) The mean station velocity (mean velocity in vertical) is calculated by integrating all velocity measurements considering their location as illustrated in [Figure 5:5](#).

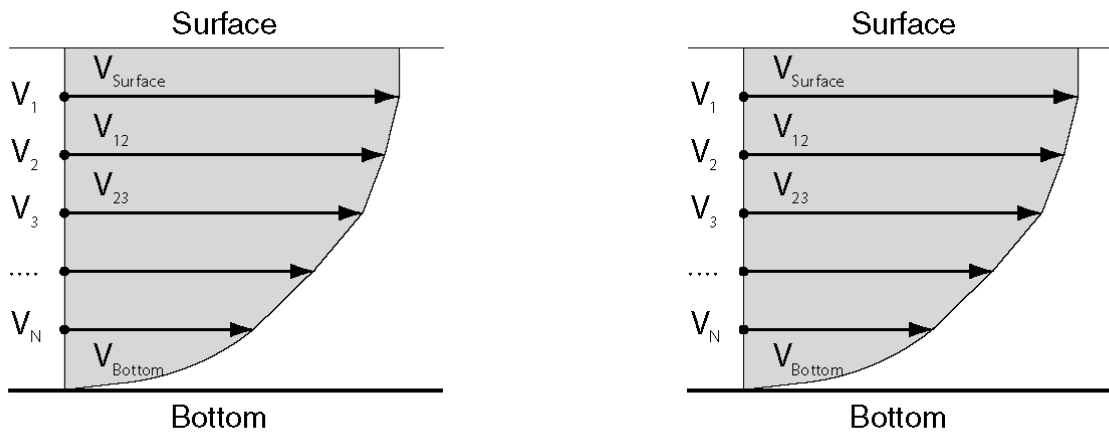

Mid and Mean Section Integration

$$V_{\text{Surface}} = V_1$$

$$V_{i(i+1)} = (V_i + V_{i+1}) / 2$$

$$V_{\text{Bottom}} = (6/7) * V_N \text{ (1/6 power law)}$$

Japanese Equation Integration

$$V_{\text{Surface}} = V_1$$

$$V_{i(i+1)} = (V_i + V_{i+1}) / 2$$

$$V_{\text{Bottom}} = (1/2) * V_N \text{ (Linear velocity change)}$$

Figure 5:5 - Vertical Velocity Curve

- c) If multiple measurements are made at the same measurement depth, these measurements are averaged prior to calculating the velocity integration.

5.1.3.3 Correction Factor

The **Correction Factor** (CF) is a user supplied parameter used to scale the mean station velocity or velocity in the vertical.

Be careful when selecting a **Correction Factor**, as the mean station velocity is always scaled by this value. Incorrect use of this parameter will affect the final discharge measurement.

- a) The **CF** is commonly used at edges, internal islands, and other method **None** stations to scale the velocity from the adjacent station(s).
- b) [Table 5:3](#) list the **Correction Factors** implemented for each Station Type and Velocity Method.

Table 5-3 – Correction Factors

Station Type	Velocity Method	Correction Factor
Bank	n/a	User defined
Island Edges	n/a	User defined
Open water	None	User defined
	0.6	1

Station Type	Velocity Method	Correction Factor
	0.2 / 0.8	1
	0.2 / 0.6 / 0.8	1
	Enter Velocity	1
Ice	None	User defined
	0.5	0.88
	0.6	0.92
	0.2 / 0.8	1
	0.2 / 0.6 / 0.8	1
	Enter Velocity	1

- c) The **CF** can consist of any value between -1.00 and 1.00, except 0.0.
- d) The **CF** can be entered for any station and the mean station velocity will be multiplied by the CF.

5.1.4 Discharge Uncertainty Calculation

Discharge Uncertainty Calculation is performed on every discharge measurement to determine the overall measurement uncertainty.

- a) The uncertainty calculation methods implemented in FlowTracker2 is based on the **Interpolated Variance Estimator (IVE)** and **ISO** methods,
- i). The **Interpolated Variance Estimator (IVE)** uncertainty calculation method uses a method developed by researchers at the U.S. Geological Survey. The IVE uncertainty calculation is the default method as it provides the most reliable indicator of measurement quality,
 - ii). The **ISO** method is based on the international standard. It provides users with the results of a published, standard technique; however, in some cases this calculation may not provide a reliable indicator of data quality.

The uncertainty analysis implemented for determining the overall discharge uncertainty are based on the following literature,



- ISO 748 – 2007, Hydrometry - Measurement of liquid flow in open channels using current meters or floats,
- Cohn, T., Kiang, J., and Mason, R., Jr. (2013). "Estimating Discharge Measurement Uncertainty Using the Interpolated Variance.

- b) The application of uncertainty calculation methods to discharge calculation methods are defined,
- i). The uncertainty calculation methods implemented are only applicable to the "Mid-Section" and "Mean-Section" discharge calculation methods.
 - ii). The Japanese method does not incorporate discharge uncertainty calculations and a method "None" is assigned.

- c) The uncertainty calculations are based on several different parameters. In addition to overall uncertainty, the FlowTracker2 also looks at the contribution of each of the following parameters.
- i). **Accuracy:** The accuracy of the FlowTracker2 calibration (this is generally negligible),
 - ii). **Depth**
 - In the **IVE** calculation, this term includes both uncertainty in the depth measurement and the effect of changes in depth between stations,
 - In the **ISO** calculation, this term includes only the uncertainty in depth measurements.
 - iii). **Velocity**
 - In the **IVE** calculation, this term includes both uncertainty in the velocity measurement and the effect of changes in velocity between stations,
 - In the **ISO** calculation, this term includes only the uncertainty in velocity measurements.
 - iv). **Width**
 - Estimated uncertainty in width measurements.
 - v). **Method:** [Determining Mean Station Velocity](#).
 - Use for the **ISO** method only.
 - vi). **Number of stations**
 - Use for the **ISO** method only.

5.1.5 Under Ice Measurements

The discharge calculation methods discussed previously in this section are also applicable for **Under Ice Measurements**. It is recommended that the operator refer to existing literature describing under ice measurements as there are number of aspects that need to be taken into account.



“Standard Operating Procedures for under ice discharge measurements using ADCPs”, Water Survey of Canada, Environment Canada, is a good reference guide for performing under ice measurements

There are a couple of additional requirements for calculating total discharge in addition to what was discussed under [Discharge Calculation Methods](#) when performing under ice measurements,

- a) Additional measurements required during under ice measurements,
 - i). Ice thickness,
 - ii). Water surface to bottom of ice,
 - iii). Water surface to bottom of slush (if slush is present).

- b) Calculating of effective depth. The effective depth is defined by the distance between the streambed and the bottom of the ice or slush in the case slush is present,
- i). 0.2 depth setting = $a + 0.2C$
 - ii). 0.8 depth setting = $b - 0.2C$
 - iii). 0.6 depth setting = $b - 0.4C$

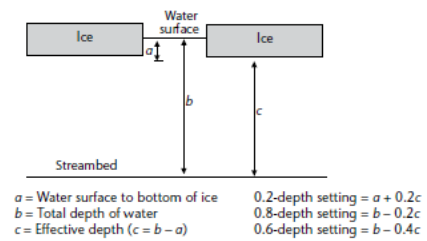

Figure 5:6 - Effective Depth

- c) Station area is calculated by multiplying the effective depth and station width.

5.1.6 Weighted Gauge Height

The **Weighted Gauge Height** during a discharge measurement is the mean water level calculated at the monitoring site during the measurement time. It is important that an accurate mean gauge height is determined as this is used with the discharge measured to develop stage-discharge relationship for the monitoring site. The methods implemented in FlowTracker2 for determining the weighted gauge height during a discharge measurement is the **average** of both the **Discharge Weighted** and **Time Weighted** gauge height.

- a) The discharge weighted process is based on the discharge calculated within the time interval associated with each set of gauge height readings. The equation of the discharge weighted method is given in [Equation 5:5](#).

Equation 5:5 - Discharge Weighted

$$H = \frac{q_1 h_1 + q_2 h_2 + q_3 h_3 + q_n h_n}{Q}$$

where,

- H is the mean gauge height,
- Q is the total discharge,
- q is the discharge measured between time interval of gauge height readings,
- h is the average gauge height readings taken between time interval.

- b) The time weighted process is based on the arithmetic mean of the gauge height calculated within the time interval associated with each set of gauge height readings.

Equation 5:6 - Time Weighted

$$H = \frac{t_1 h_1 + t_2 h_2 + t_3 h_3 + t_n h_n}{T}$$

where, H is the mean gauge height,

T is the total time for the measurement,
t is the duration of time interval between gauge height readings,
h is the average gauge height readings taken between time interval.



The method for determining the weighted gauge height are based on the following literature,

- Measurement and Computation of Stream flow: Volume 1. Measurement of Stage and Discharge. Page 170. By S. E. RANTZ and others

5.2. General Mode

The **General Mode** of data collection is for applications that need a series of velocity measurements at different locations that do not require a standard discharge output.

5.2.1 Measurement Technique

The basic **Measurement Technique** used for performing velocity measurements using General Mode is briefly discussed below. The measurement technique differs from the Discharge Mode where the objective is to determine water velocity at specific locations.

- The measurement location is not required to comply with any measurement site or hydraulic requirements stipulated in [Site Selection Requirements](#).
- The flow conditions at the measurement location should be within the FlowTracker2 specifications.
- Station is created for each point velocity measurement assigned a unique X and Y coordinate.
- Station velocity measurement performed at user defined location and depth.

5.2.2 Determining Mean Velocity

The **Mean Velocity** outputs generated from velocity measurements performed in General Mode consist of Mean Station Velocity and Mean Velocity of All Stations.

- The **Mean Station Velocity** is the average of the velocity measurements performed over a user defined sampling interval at a specific measurement depth.
- The **Mean Velocity of All Stations** is the average of all the station measurements performed each at its own unique location and measurement depth.

Section 6. Quality Control

Quality Control (QC) is continuously performed on all variables collected during a measurement in both Discharge and General Modes. The [Quality Control Parameters](#) are automatically reviewed at different stages of a measurement and if any values exceed the expected criteria a warning is supplied.

6.1. Quality Control Parameters

Quality Control Parameters used to analyze the variables collected during a measurement are discussed in the following section. The quality control parameters with its expected values are supplied in [Table 6:1](#). All quality control parameters can be adjusted or disabled based on measurement site and or user requirements.

Table 6-1 - Quality Control Parameters

Parameter	Description	Expected
SNR	<p>SNR is the most important Quality Control parameter,</p> <ul style="list-style-type: none"> • It measures the strength of the acoustic reflection from particles in the water, • Without sufficient SNR, the FlowTracker2 cannot measure velocity. 	Ideally > 10 dB Minimum ≥ 4 dB
Velocity Standard Error	<p>σV (velocity standard error) is a direct measure of the accuracy of velocity data,</p> <ul style="list-style-type: none"> • It includes the effects of turbulence in the river and instrument uncertainty. 	Typically < 0.01m/s (0.03 ft/s). Higher in turbulent environment.
Boundary Interference	<p>Boundary QC evaluates the measurement environment for interference from underwater obstacles,</p> <ul style="list-style-type: none"> • FAIR or POOR results may indicate significant interference from an underwater obstacle. 	<ul style="list-style-type: none"> • BEST, • GOOD, • FAIR, • POOR.
Velocity Spike Filtering	<p>Spikes in FlowTracker2 velocity data are removed using a spike filter,</p> <ul style="list-style-type: none"> • Some spikes are common and no cause for concern, • Too many spikes indicate a problem in the measurement environment (e.g., interference from underwater obstacles or highly aerated water). 	Typically < 5% of total samples. Should be < 10% of total samples.
Velocity Angle	<p>Angle is the direction of the measured velocity relative to the FlowTracker2 X-axis,</p> <ul style="list-style-type: none"> • Used for discharge measurements only, • A good site should have small velocity angles, 	Ideally < 20°

Parameter	Description	Expected
	<ul style="list-style-type: none"> Large angles may be unavoidable at some sites. 	
Tilt Angle	<p>Angle of the wading rod relative to the vertical,</p> <ul style="list-style-type: none"> Used for both discharge and general mode, A good measurement should have small tilt angles, Large tilt angles may be unavoidable at some sites. 	Ideally < 5°
Station Percent Discharge	<p>%Q is the percentage of the total discharge in a single measurement station,</p> <ul style="list-style-type: none"> Most agencies have criteria for the maximum %Q. 	Typical criteria: Ideally < 5% Maximum < 10%
Station Water Depth	<p>Depth is the maximum percentage variation in depth between adjacent stations.</p>	Typical criteria: Maximum < 50%
Station Location	<p>Location is the maximum percentage variation in location between adjacent stations.</p>	Typical criteria: Maximum < 100%
Velocity Profile 0.2 \ 0.8	<p>0.2 \ 0.8 Velocity Profile evaluated against expected velocity distribution,</p> <ul style="list-style-type: none"> Used for discharge measurements only, Suggest 0.6 depth measurement if set criteria is complied with. 	Ideally: near-surface velocity > n Velocity

6.1.1 Signal to Noise Ratio (SNR)

Signal to Noise Ratio (SNR) is a measure of the strength of the reflected acoustic signal relative to the ambient noise level of the FlowTracker2. SNR is the most important quality control data provided by the FlowTracker2.

- SNR is reported in logarithmic units (dB). It is recorded with each one-second velocity sample.
- For the best operating conditions, SNR should be greater than 10 dB.
- The FlowTracker2 can operate reliably with SNR as low as 4 dB, although the noise in individual measurements will increase.
- Low SNR indicates a lack of suspended material in the water. For clear water, seeding material can be introduced to increase SNR. Seeding is typically only required in large laboratory tanks. Most field applications have sufficient natural scattering material.
- The SNR data displayed during and after a point velocity measurement and when a station and or stations are completed in both General and Discharge Modes are supplied in [Table 6:2](#). Individual beam SNR data can be accessed by exporting the raw data in either JSON or CSV format from FlowTracker2 desktop

**SNR
Data
Display**

software,

Table 6-2 – SNR Data Types

Mode	Reporting	Type	Description
All	Graphical	Raw Data	One second SNR data is displayed for each beam and color codes based on the beam number (see Table 4:4).
		Moving Average	Moving average is calculated of the one second SNR data and is graphically displayed with the raw SNR data.
	Real Time	Raw Data	Instantaneous one second raw SNR data is displayed with the graphical display.
Discharge	Review Point Measurement	Mean Point Measurement SNR	The point measurement SNR is the mean of beam 1 and 2 at the point measurement. Receiver 3 (if installed) is not used in the mean calculation because we assume the probe is side-looking (either a 2D or 2D/3D probe), and only Vx and Vy are of interest. Receiver 3, which is only used for Vz, is irrelevant.
	Review Station	Mean Station SNR	The station SNR is the mean of all point measurements at a station.
	Discharge Summary	Mean Section SNR	The discharge summary SNR is the mean of all the station mean SNR within the section
General	Review Point Measurement	Mean Beam SNR at Point Measurement	The point measurement SNR is the mean of one second SNR data for each individual beam (2 or 3 depending on probe type) at the point measurement.
	Review Station	Mean Beam SNR at Station	The station SNR is the mean for each individual beam (2 or 3 depending on probe type) of all point measurements at a station.
	General Summary	Mean SNR	The general summary SNR is the mean of all individual beam SNRs at all point measurements.

- f) SNR is the most important quality control data provided by the FlowTracker2. SNR is evaluated against number of quality control criteria and at the end of each velocity point measurement, the following SNR checks are run in General mode and Discharge mode.
 - i). SNR from all beams must be greater than 4 dB for reliable data collection.
 - ii). **Low SNR.** If the SNR of any beam is below 4.0 dB, “Low SNR” alert will be given at the end of point and section measurement.

**SNR
Data
Evaluate**

- For 2D systems, if the SNR of either beam is low, this will affect all velocity data even if the other beam shows higher SNR values.
 - For 2D/3D systems, if only the SNR of Beam 3 is low, vertical velocity data (Vz) are affected; the horizontal velocity data (Vx and Vy) may still be valid. This can occur if Beam 3 is out of the water in very shallow water.
- iii). **Approach Low SNR.** If the SNR is between 4 and 7 dB, “*Approach Low SNR*” alert will be given at the end of point and section measurement.
- iv). **Beam SNRs Not Similar.** When the difference between any two beams is greater than SNR Threshold,
- This may indicate interference from an underwater obstacle or a potential problem with the probe,
 - At the first alert, repeat the measurement (perhaps after moving probe location),
 - If the problem persists, run [Beam Check](#) to evaluate FlowTracker2 operation in more detail.
- v). **Large SNR Variation.** When the standard deviation of the SNR of each beam during the measurement is greater than a fixed threshold of 5 dB,
- This may indicate interference from an underwater obstacle, a highly turbulent environment, or highly aerated water,
 - At the first alert, repeat the measurement (perhaps after moving probe location),
 - If the problem persists, evaluate the measurement environment. In some cases, large variations may be unavoidable and may not impact the quality of velocity data.
- vi). **SNR Threshold Variation.** When SNR for a new measurement differs from the mean of three or more completed stations in this measurement by more than SNR Threshold,
- This may indicate interference from an underwater obstacle or some other dramatic change in stream conditions,
 - At the first alert, repeat the measurement (perhaps after moving probe location),
 - If the problem persists, evaluate the measurement environment to look for any potential cause for the change in SNR.
- vii). **SNR Threshold** is checked with the completion of a point velocity measurement and measurement section (see [Timing of Warning Messages](#)).
- User is notified of any stations that exceed the above criteria.
 - If desired, user can delete suspect stations and repeat the measurements.

- g) The SNR checks are re-run (Discharge mode and General mode measurement) to ensure the warnings are set with the most current data.
- h) This criterion can be adjusted or disabled under [Quality Control Settings](#).



SNR is primarily a function of the amount and type of particulate matter in the water. SNR cannot be immediately converted to sediment concentration, it provides an excellent qualitative picture of sediment fluctuations and with proper calibration, SNR can be used to estimate sediment concentration.

6.1.2 Velocity Standard Error

Standard Error of Velocity (σ_V) is a direct measure of the accuracy of the mean velocity data.

- a) σ_V can be directly interpreted as the accuracy of the mean velocity.
- b) σ_V is calculated by dividing the standard deviation of one-second samples by the square root of the number of samples.
- c) σ_V is normally dominated by real variations in the flow and will vary depending on the measurement environment (see [Principle of Operations](#)).
- d) The σ_V displayed after a point velocity measurement, station and or stations are completed in both General and Discharge Modes are supplied in [Table 6:3](#).

σ_V Data Display

Table 6-3 – σ_V Data Types

Mode	Reporting	Type	Description
Discharge	Review Point Measurement	σ_V Point Measurement	X-component velocity standard error.
	Review Station	Mean Station σ_V	The station σ_V is the mean of the X-component velocity standard error from each point velocity measurement.
	Discharge Summary	Mean Section σ_V	The discharge summary σ_V is the mean of all stations average X-component velocity standard error.
General	Review Point Measurement	Beam σ_V at Point Measurement	The point measurement σ_V for each individual beam (2 or 3 depending on probe type) at the point measurement.
	Review Station	Mean Beam σ_V at Station	The station σ_V is the mean for each individual beam (2 or 3 depending on probe type) of all point measurements at a station.
	General Summary	Mean σ_V	The general summary σ_V is the mean of all stations average X-component velocity standard error.

σ_V Data Evaluate

- e) σ_V is evaluated against number of quality control criteria and at the end of each velocity point measurement, the following velocity standard error checks are run

in General mode and Discharge mode.

- i). The standard error threshold for each measurement is the greater of the following,
 - **σV Threshold** (default 0.01 m/s / 0.033 ft/s),
 - If the mean **σVx** for three or more completed stations measurements is greater than **σV Threshold**, then increment the **σV Threshold** by the mean value (**Mean σVx + σV Threshold**),
 - If the **σV Threshold** is larger than 0.250m/s, then set **σV Threshold** equal to 0.250m/s.
 - If the mean spike filtered X-component velocity (high velocity has higher **σVx**) is larger than **σV Threshold** then set **σV Threshold** to 5% of X-component velocity.
- ii). When **σVx** is greater than the standard error threshold for that measurement,
 - This may indicate interference from an underwater obstacle, a highly turbulent environment, or highly aerated water,
 - At the first alert, repeat the measurement (perhaps after moving probe location),
 - If the problem persists, evaluate the measurement environment. In some cases, large variations may be unavoidable (e.g., in highly turbulent waters).
- iii). **σV Threshold** is checked with the completion of a point velocity measurement and measurement section (see [Timing of Warning Messages](#)).
 - User is notified of any stations that exceed the above criteria.
 - If desired, user can delete suspect stations and repeat the measurements.
- f) If the point measurements X-component velocity standard error is 0 or if it exceeds the updated **σV Threshold** then a **Standard Error > QC** warning is given.
- g) The velocity standard error checks are re-run (Discharge mode and General mode measurement) to ensure the warnings are set with the most current data.
- h) This criterion can be adjusted or disabled under [Quality Control Settings](#).

6.1.3 Boundary Interference

The **Boundary Interference** quality control looks for interference from underwater objects that are in or close to the FlowTracker2 sampling volume. The system tries to avoid this interference, but you must be aware of system limitations.

- a) The impact of underwater objects and or boundaries on the measurement is related to the FlowTracker2 principle of operation.
 - i). Reflections can occur from the bottom, the water surface, or submerged objects (e.g., rocks).

- ii). The FlowTracker2 measures velocity in a sampling volume 10 cm (4 in) from the probe tip.
 - iii). If the sampling volume is on top of or beyond an underwater object, velocity data will be meaningless.
- b) When working in very shallow water or near underwater obstacles (with the sampling volume within 15 cm (6 in) of the obstacle), acoustic reflections can potentially affect velocity data.
- i). At each measurement location, the FlowTracker2 looks for these conditions, and if necessary, adapts its operation to avoid interference.
 - ii). For most locations, any required changes do not affect system performance.
 - iii). In some environments, changes may result in a lower maximum velocity.
- c) The FlowTracker2 records any changes required to avoid acoustic interference. It reports this as **Boundary QC**. This value describes the effect (if any) of boundary adjustments on performance. The **Boundary QC** variable (**Bnd**) can have the following values (0 and 1 are the most common).

Boundary Display

0 (Best)	<ul style="list-style-type: none"> •No boundary adjustments were necessary, or if necessary, they have minimal impact on system performance. Maximum velocity is at least 3.5 m/s (11 ft/s)
1 (Good)	<ul style="list-style-type: none"> •Minor boundary adjustments were necessary, with moderate impact on system performance. Maximum velocity is at least 2.5 m/s (8 ft/s).
2 (Fair)	<ul style="list-style-type: none"> •Larger boundary adjustments were necessary, with notable impact on system performance. Maximum velocity is at least 1.2 m/s (4 ft/s).
3 (Poor)	<ul style="list-style-type: none"> •Major boundary adjustments were necessary, with significant impact on system performance. Maximum velocity is less than 1.2 m/s (4 ft/s). The FlowTracker will still provide good performance for lower flows.

Figure 6:1 - Boundary QC Conditions

Boundary Data Evaluate

- d) The **Boundary Interference** check looks for interference with underwater objects that are in or close to the FlowTracker2 sampling volume. The FlowTracker2 automatically adapts its pinging to minimize boundary interference, but it can only adapt so much, and the resulting pings could still be influenced by the boundary. The FlowTracker2 software receives two values from the firmware to use in determining the amount of boundary interference: velocity ambiguity and the best single ping precision, both available in m/s.
- i). If the **Boundary QC** results are **FAIR** or **POOR**, this indicates possible interference, and the FlowTracker2 will issue an alert before the measurement is made.

- User is prompted to consider moving the probe to avoid this interference.
 - If the probe is moved, repeat the boundary test prior to data collection.
 - If repeated Boundary QC tests do not give improved results, user can proceed with the measurement, but should carefully evaluate velocity data.
- ii). The **Boundary Interference** is checked before a point velocity measurement is made and if the condition is not “Best”, then the Boundary Interference warning is given (see [Timing of Warning Messages](#)).
- e) This criterion can be adjusted or disabled under [Quality Control Settings](#).

6.1.4 Velocity Spike Filter

The **Velocity Spike Filter** quality control is applied to each point velocity measurements in both General mode and Discharge mode. Spikes in velocity data occur with any acoustic Doppler velocity sensor such as the FlowTracker. Spikes may have a variety of causes – large particles, air bubbles, or acoustic anomalies.

Filter Method

- a) The FlowTracker2 spike filter is a variation on a method called “Tukey’s Outlier. Just like in Tukey’s method, the data are sorted in ascending order, then divided into 4 quartiles.
- i). A histogram of each velocity component is calculated.
 - ii). The FlowTracker2 determines the 1st Quartile (**Q1**) velocity value where 25% of the samples are less than this value. The 3rd Quartile (**Q3**) is the velocity value where 75% of the samples are smaller than this value. The Interquartile Range (**IQR**) is defined as the spread between the 1st Quartile and the 3rd Quartile (**IQR = Q3-Q1**).
 - iii). If the **IQR** is less than 0.015 m/s, **IQR** is set to 0.015 m/s.
 - iv). Any value less than (**Q1-2*IQR**) or greater than (**Q3+2*IQR**) is considered a spike and is not used for mean velocity calculations.
- b) Spikes are filtered based on all velocity components (Vx, Vy, and Vz). If any velocity component falls outside the above limits, that sample is not used for the mean velocity, standard deviation or velocity standard error calculation.

Spike Data Display

- c) No other filtering or editing is done to FlowTracker2 velocity data.
- d) The number of spikes is displayed and recorded at the end of each measurement.

Spike Data Evaluate

- e) Raw, one-second velocity data are recorded with each measurement station. This allows you to evaluate unedited velocity data for each station.
- f) The **Velocity Spike Filter** is applied to each point velocity measurements in both General mode and Discharge mode, but the filter is not attempted unless there are at least 10 samples in a measurement. The **Spike Threshold** (default 10%) is used as follows to determine the number of velocity spikes present in the data.

- i). If the number of spikes is a greater percentage of the total number of points than specified by the **Spike Threshold**, a warning is given.
 - This may indicate interference from an underwater obstacle, a highly turbulent environment, or highly aerated water.
 - At the first alert, repeat the measurement (perhaps after moving probe location).
 - If the problem persists, evaluate the measurement environment – a large number of spikes may be unavoidable, but may not overly impact the quality of velocity data.
- ii). The **Spike Threshold** is checked with the completion of a point velocity measurement and measurement section (see [Timing of Warning Messages](#)).
 - User is notified of any stations that exceed the above criteria.
 - If desired, user can go back and delete suspect stations and repeat the measurements.
- g) The **Velocity Spike Filter** is checked at the end of each point velocity measurement and if the number of velocity spikes is larger than allowed by the **Spike Threshold**, then give the **High % Spikes** warning.
- h) The velocity spike filter check is re-run (Discharge mode and General mode measurement) to ensure the warnings are set with the most current data.
- f) This criterion can be adjusted or disabled under [Quality Control Settings](#).

6.1.5 Velocity Angle

The **Velocity Angle** quality control parameter is applied to each point velocity measurement in **Discharge** mode.

- a) For an ideal discharge measurement site, flow should be perpendicular to the tag line used to define the cross section.
- b) A good measurement site will typically show some flow variations, but with all angles less than about 20°.
- c) The ability of the FlowTracker2 to measure the 2D flow eliminates the need to estimate the flow direction with each measurement, as is required for most 1D current meters. This reduces a potential source for error in velocity measurements.
- d) Velocity angle is defined as the direction of flow relative to the X direction, and is calculated as **atan(Vy/Vx)**.
 - i). The FlowTracker's X-axis is always held perpendicular to the tag line.

Velocity Angle Method

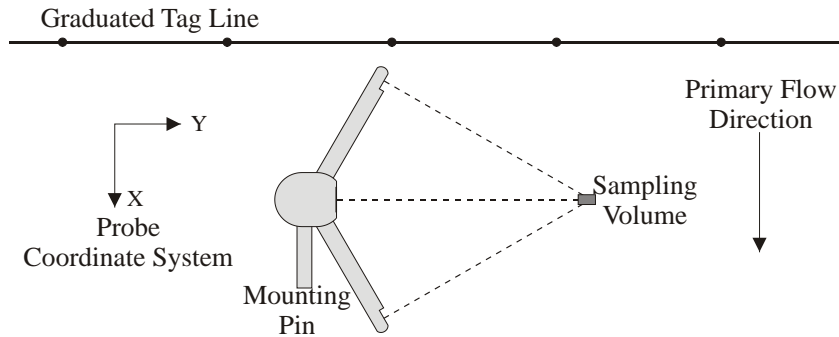

Figure 6:2 – FlowTracker2 Probe Orientation Relative to Stream Flow

**Velocity
Angle
Evaluate**

- ii). An angle of 0° means flow direction is perpendicular to the tag line (as desired for an ideal measurement location).
 - iii). Only the X component of velocity (V_x) is used for discharge calculations. This ensures proper discharge measurements regardless of the flow direction.
- e) The Velocity Angle measured is evaluated to ensure reliable data collection. The velocity angle for a point measurement is computed from the de-spiked point measurement mean velocity components as $\text{angle} = \text{atan2}(V_y, V_x)$. The **Max Angle** criterion (default 20°) is used as follows.
- i). Velocity angle is checked only if velocity is greater than a fixed threshold (0.02 m/s; 0.07 ft/s).
 - ii). When measured angle is greater than **Max Angle**, a warning is given.
 - Evaluate the measurement site to verify the measured angle is reasonable.
 - Consider repeating the measurement if the angle does not appear reasonable (perhaps after moving probe location).
 - For large velocity angles, consider moving the measurement site.
 - iii). The **Max Angle** is checked with the completion of a point velocity measurement and measurement section (see [Timing of Warning Messages](#)).
 - User is notified of any stations that exceed the above criteria.
 - If desired, user can go back and delete suspect stations and repeat the measurements.
 - f) The Velocity Angle is checked at the end of each point velocity measurement and if the measurement's mean velocity X component is at least 0.02 m/s and if the velocity angle is larger than **Max Velocity Angle**, then give the **Velocity Angle > QC** warning.
 - g) The velocity angle check is re-run (Discharge mode and General mode measurement) to ensure the warnings are set with the most current data.
 - h) **Max Angle** is active only in **Discharge** data collection mode.
 - i) This criterion can be adjusted or disabled under [Quality Control Settings](#).

6.1.6 Tilt Angle

The **Tilt Angle** quality control is applied to each point velocity measurements in both General mode and Discharge mode

Tilt Method

- a) A good measurement will typically show variations in wading rod angle, but with all angles less than about 5°.
- b) Tilt angle is defined as the angle of the wading rod relative to the vertical.

Tilt Evaluate

- i). The tilt angle of 0° means that the wading rod is vertical.
- ii). The tilt angle is only an indicator and not used in any calculations
- c) If the wading rod angle exceeds **Max Wading Rod Angle**, a warning is issued; you are prompted to realign the wading rod.
 - i). When measured angle is greater than **Max Angle**, a warning is given.
 - Evaluate the measurement to verify the measured angle is reasonable.
 - Consider repeating the measurement if the angle does not appear reasonable (perhaps after moving probe location).
 - ii). The **Max Wading Rod Angle** is checked with the completion of a point velocity measurement and measurement section (see [Timing of Warning Messages](#)).
 - User is notified of any point velocity measurement that exceeds the above criteria.
 - If desired, user can go back and delete suspect point velocity measurement and repeat the measurements.
- d) The tilt angle is checked at the end of every point velocity measurement and if the wading rod angle > **Max Wading Rod Angle**, then give the **Velocity Angle > QC** warning.
- e) The tilt angle is checked at the end of a section and reports the stations where the tilt angle exceeds **Max Wading Rod Angle**.
- f) This criterion can be adjusted or disabled under [Discharge Settings](#).

6.1.7 Station Percent Discharge

Most agencies that perform discharge measurements expect that no individual station should contain more than a certain percentage of the total discharge. The **Max Station Q** criterion (default 10%) alerts you if this standard is exceeded.

% Stn Q Method

- a) The user can set the discharge reference to either “rated” or “measured”. The reference is used when computing the discharge percent to display. When the discharge percent is calculated,
 - i). The rated discharge is used only at the end of each station,
 - ii). The measured discharge is used only at the end of a section.

**% Stn Q
Evaluate**

- b) If the station discharge exceeds **Max Station Q** percent of the rated flow, a warning is issued; you are prompted to consider adding another station.
 - i). If rated flow is entered, the discharge from each station is checked against this rated value when the station is completed.
 - ii). **Max Station Discharge** is checked at the end of each station and measurement section (see [Timing of Warning Messages](#)).
 - User is notified of any stations that exceed the Max Depth Change criterion.
 - User is prompted to verify the depth value or re-enter the depth.
- c) The maximum station discharge is checked at the end of a station and if the ratio of station discharge to rated discharge > **Max Station Discharge**, then give the **High Stn % Discharge** warning.
- d) The maximum station discharge is checked at the end of a section and reports the stations where the percent of station discharge to total discharge exceeds **Max Station Discharge**.
- e) **Max Station Discharge** is active only in **Discharge** data collection mode.
- f) This criterion can be adjusted or disabled under [Discharge Settings](#).

6.1.8 Station Water Depth

The **Max Depth Change** criterion (default 50%) is intended to avoid data entry errors.

**Max
Depth
Evaluate**

- a) It is assumed that depth changes between stations will be gradual.
- b) If the entered depth is different from a reference by more than Max Depth Change (and at least 0.20 m; 0.66 ft) an alert is issued to be sure the depth was not incorrectly entered.
 - i). If only the previous station is available, the newly entered depth is compared to the depth from the previous station.
 - ii). If depth data are available on both sides of this station, the newly entered depth is compared to an interpolated depth between the two adjacent stations.
 - iii). **Max Depth Change** is checked during station configuration and at the end of a measurement section (see [Timing of Warning Messages](#)).
 - User is notified of any stations that exceed the Max Depth Change criterion.
 - User is prompted to verify the depth value or re-enter the depth.
- c) Water depth is checked of each station and if the water depth varies from the reference depth by a percentage larger than **Max Depth Change**, then give the **Water Depth Change > QC** warning.
- d) The station water depth check is re-run (only for Discharge mode) to ensure the warnings are set with the most current data.
- e) **Max Depth Change** is active only in **Discharge** data collection mode.
- f) This criterion can be adjusted or disabled under [Discharge Settings](#).

6.1.9 Station Location

The **Max Spacing Change** criterion (default 100%) is intended to avoid data entry errors.

Max Station Evaluate

- a) It is assumed that the spacing of adjacent stations will be nearly constant across the river.
- b) If spacing between stations has changed by more than **Max Spacing Change**, an alert is issued to be sure the location was not incorrectly entered. A 100% **Max Spacing Change** means the new station spacing is more than two times the previous station spacing.
 - i). Determine if the station location trend is expected to be increasing or decreasing by comparing the location of the first two stations. All stations are expected to match this trend.
 - ii). Any time a station location is changed, the location is compared to adjacent value(s) to see if the station is out of order.
 - If the trend in location from the previous station to this station does not match the expected trend, then give the **Station Order** warning.
 - If the trend in location from this station to the next station does not match the expected trend, then give the **Station Order** warning.
 - Collecting an out-of-order station is allowed. However, when an out-of-order station is entered we verify the location value since the station is sorted into the correct place within the stream.
 - iii). Any time a station location is changed, the location is compared to the starting edge location. If the new location is outside the starting edge, a **Location Outside Edge** warning is given.
 - iv). **Max Station Change** is checked during station configuration (see [Timing of Warning Messages](#)).
 - User is notified of any stations that exceed the Max Station Change criterion.
 - User is prompted to verify the location value or re-enter the location.
- c) The expected station spacing is computed from the previous two station locations. If the station spacing from the previous station to this location is more than **Max Spacing Change** percent of the expected station spacing, then give the **Stn Spacing > QC** warning. A warning will be triggered only if the station spacing is too big (there is no warning that it is too small).
- d) The station location check is re-run (only for Discharge mode) to ensure the warnings are set with the most current data.
- e) **Max Spacing Change** is active only in **Discharge** data collection mode.
- f) This criterion can be adjusted or disabled under [Discharge Settings](#).

6.1.10 Velocity Profile 0.2 \ 0.8

The **Velocity Profile 0.2 \ 0.8** criterion is intended to identify unusual velocity distribution within the measurement profile.

- a) For an ideal discharge measurement site, the velocity distribution in the measurement profile should follow 1/6 power-law.
- b) The velocity measurements performed at 0.2 time depth and 0.8 time depth are evaluated against expected velocity profile. If any of the following conditions are true, this indicates an unusual velocity profile, and the user is given the option to add a third velocity measurement at 0.6 time depth.
 - i). The magnitude of the near-surface velocity (0.2 times depth) is less than the magnitude of the near-bottom velocity (0.8 times depth).
 - ii). The magnitude of the near-surface velocity (0.2 times depth) is more than two times the magnitude of the near-bottom velocity (0.8 times depth).
 - iii). The near-surface velocity (0.2 times depth) and near-bottom velocity (0.8 times depth) show flow in the opposite direction.

Velocity Profile Evaluate

6.2. Quality Control Warning Messages

6.2.1 Types of Warning Messages

Quality Control Warning Message is supplied when measured variable exceeds the expected criteria of each parameter in [Quality Control Parameters](#). The quality control warning messages implemented in the Quality Control process are supplied in [Table 6:4](#). The table layout describing the quality control warning messages consist of the following key components,

- a) **Warning**, the warning supplied when the parameter is exceeded,
- b) **Reporting**, aspect of the measurement process relate to the quality control warning message,
- c) **QC Criteria**, quality control criteria based on SonTek default values or user specified.

Table 6-4 - Quality Control Warning Messages

Warning	Reporting	QC Criteria	Description	Suggested Action
Low SNR	Point Velocity	Low SNR	SNR below 4 dB	<ul style="list-style-type: none"> • Improve SNR
Approach Low SNR	Point Velocity	Approach Low SNR	SNR between 4db and 7 dB	<ul style="list-style-type: none"> • Improve SNR
Beam SNRs Not Similar	Point Velocity	SNR Threshold	Difference in SNR for any 2 beams is > SNR Threshold .	<ul style="list-style-type: none"> • Look for underwater obstacles; repeat measurement. • Check probe operation
Large SNR Variation	Point Velocity	SNR Variation	One-second SNR data varies more than expected during a measurement. May indicate underwater interference or a	<ul style="list-style-type: none"> • Look for underwater obstacles; repeat measurement. • Look for environmental

Warning	Reporting	QC Criteria	Description	Suggested Action
			highly aerated environment.	sources (e.g., aerated water).
SNR Threshold Variation	Point Velocity	SNR Threshold	SNR more than SNR Threshold different from previous measurements; major change in measurement conditions.	<ul style="list-style-type: none"> Look for underwater obstacles or other changes in river condition. Repeat measurement
Standard Error > QC	Point Velocity	σV Threshold	$\sigma V > \sigma V$ Threshold ; adjusted based on previous data and measured velocity. May indicate interference or a highly turbulent environment.	<ul style="list-style-type: none"> Look for underwater obstacles or a change in conditions. Consider real turbulence levels in river. Repeat measurement.
Boundary Interference	Point Velocity	Boundary Interference	Boundary QC is FAIR or POOR. Indicates possible interference from underwater obstacles.	<ul style="list-style-type: none"> Consider re-locating probe and repeating test. Measurement can proceed if results are consistent.
High % Spikes	Point Velocity	Spike Threshold	Spikes > Spike Threshold percent of samples. May indicate poor measurement conditions.	<ul style="list-style-type: none"> Look for underwater obstacles or unusual conditions (e.g., aerated water). Repeat measurement.
Velocity Angle > QC	Point Velocity	Max Velocity Angle	Angle > Max Velocity Angle. May only indicate non-ideal measurement environment.	<ul style="list-style-type: none"> Consider if measured angle is realistic. Repeat measurement if needed.
Rod Angle > QC	Point Velocity	Max Wading Rod Angle	Angle > Max Wading Rod Angle. May indicate non-ideal measurement method.	<ul style="list-style-type: none"> Consider if measured angle is realistic. Repeat measurement if needed.
High Stn % Discharge	Station	Max Station Discharge	%Q > Max Station Discharge. Station contains a large portion of the total discharge.	<ul style="list-style-type: none"> Consider adding more stations.
Water Depth > QC	Station	Max Depth Change	Station depth differs from adjacent stations by more than Max Depth Change % . This may indicate data entry problem.	<ul style="list-style-type: none"> Verify station depth value. Re-enter if needed.
Stn Spacing > QC	Station	Max Spacing Change	Spacing between stations has changed by more than Max Spacing Change % . This may indicate a data entry problem.	<ul style="list-style-type: none"> Verify station location value. Re-enter if needed.
Station Order	Station	None	Station location out of sequence or outside river edge. This may indicate a data entry problem.	<ul style="list-style-type: none"> Verify station location value. Re-enter if needed.
Location Outside Edge	Station	None	Station location out of sequence or outside river edge. This may indicate a data entry problem.	<ul style="list-style-type: none"> Verify station location value. Re-enter if needed.

Warning	Reporting	QC Criteria	Description	Suggested Action
Fractional Depth > 1	Point Velocity	None	Fractional Depth < 1. Verify ratio between measurement depth and total depth and this should not >1	<ul style="list-style-type: none"> • Verify fractional depth value. • Re-enter if needed.

6.2.2 Timing of Warning Messages

The quality control warning messages are supplied at certain stages of the measurement process for both the Discharge and General Modes. The timing of the quality control warning messages are supplied in [Table 6:5](#). “D” indicates Discharge mode and “G” indicates General mode.

Table 6-5 - Timing of Quality Control Warning Messages

Warning Messages	Station Setup	Pre Measurement	Post Measurement	Post Station	Post Section
Low SNR			D,G		D,G
Approach Low SNR			D,G		D,G
Beam SNRs Not Similar			D,G		D,G
Large SNR Variation			D,G		D,G
SNR Threshold Variation			D,G		D,G
Standard Error > QC			D,G		D,G
Boundary Interference		D,G			
High % Spikes			D,G		D,G
Velocity Angle > QC			D		D
Rod Angle > QC			D,G		D,G
High Stn % Discharge				D	D
Water Depth > QC	D				D
Stn Spacing > QC	D				
Station Order	D				
Location Outside Edge	D				
Fractional Depth > 1		D,G			D,G

6.3. Beam Check

Beam Check operates by sending a pulse of sound into the water, and then plotting the signal to noise ratio of the return signal versus range for each of the FlowTracker2 receivers. This information can be evaluated to determine the effective measurement range, to look for interference from boundaries/structures, to survey a deployment site, or to observe the quality of the returned signal.

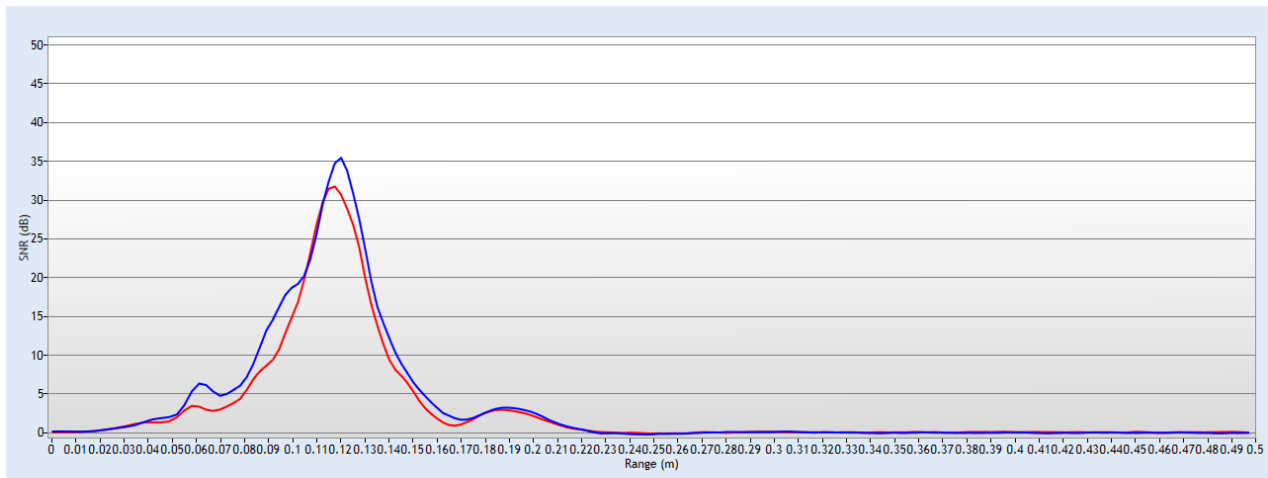

Figure 6:3 - Beam Check

6.3.1 Beam Check Overview

The FlowTracker2 transmits a pulse of sound, it then receives the return signal to noise ratio for each of the 2 (or 3) receivers as a function of time following the transmit pulse. Features in the signal to noise ratio profile verify different aspects of system performance,

- a) The horizontal axis indicates the range from the FlowTracker2 probe (in m).
- b) The vertical axis is in signal to noise ratio units called SNR (in dB).
- c) Ringing from the transmit pulse appears on the left side of the graph.
- d) The location of the sampling volume is indicated by increased signal to noise ratio in a bell-shaped curve,
 - i). The sampling volume curve corresponds to the transmit pulse passing through the focal point of the receivers,
 - ii). The peak of this curve corresponds to the center of the sampling volume,
 - iii). The location of the sampling volume varies from probe to probe, but is typically 10-12 cm,
 - iv). All receivers (2 or 3) should see the peak in the same location, although there will be variation in the height and shape of the curve.
- e) A sharp spike indicates a boundary reflection (if a boundary is within range),
 - i). If the probe is close to a boundary, a sharp reflection should be seen,
 - ii). The size and shape of this reflection will vary depending on the nature of the boundary, its distance from the FlowTracker2 and the acoustic conditions of the water,
 - iii). We can estimate the distance from the probe to the boundary by the location of the boundary reflection.
- f) After the boundary reflection, the signal to noise ratio flattens out in the region where there is no reflected signal from the water,

- i). Signal to noise ratio decreases to the electronic noise level past the boundary and is typically about 30-70 counts,
 - ii). An easy way to measure the instrument noise level is to run Beam Check when the probe is not in the water. In this case, the entire plot should show a constant return at the instrument's noise level.
- g) When using Beam Check, it is important to understand that the output plot will vary considerably because of the nature of acoustic scattering,
- i). The shape and height of the return signal, particularly the bell curve for the sampling volume, will show considerable variation between updates,
 - ii). Each of the items described above should be visible ([Figure 6:1](#)),
 - iii). If no sampling volume peak can be seen, try adding some fine dirt or other [Seeding](#) material and stirring the water to increase the signal to noise ratio.
 - iv). If the Beam Check output differs significantly from the sample shown here, refer to [Diagnosing Measurements with Beam Check](#) for more details about interpreting this data.

6.3.2 Beam Check Features

- **Sample** - Indicates the number of the transmitted pulse that is currently being displayed on the graph and in the tabular data boxes. If real-time or previously recorded (archived) data is being displayed, only the current sample number is displayed.
- **Sample Averaged** - When **Averaging** has been selected, this box indicates the number of samples that have been averaged together for the currently displayed graph and tabular data.
- **Noise Level** - Shows the electronics noise level for the receiver of each beam. This value is determined by the signal to noise ratio when the instrument is not receiving any return reflections from the water. This value should match the signal to noise ratio for the flat portion of the graph. The noise level is displayed in SNR.
- **Peak Position** - This is the location of the center of the peak for the sampling volume for each of the receivers. The position of the peak should be about the same for each receiver.
- **Peak Level** - This is the height of the peak for the sampling volume for each of the receivers. This will vary depending on the amount of scattering material in the water.
- **Graph Range (X-axis)** - The graph itself shows a plot of the signal to noise ratio for each beam as a function of range following the transmit pulse. The range portion is shown along the graph's X-axis and the value can be shown in centimeters, meters, etc.
- **Graph SNR (Y-axis)** - The graph itself shows a plot of the signal to noise ratio (SNR) for each beam as a function of range following the transmit pulse. The SNR portion is shown along the graph's Y-axis and the value is shown in SNR.

6.3.3 Beam Check Operation

Beam Check can be performed in either a small tank, bucket of water or measurement section in canal or river such that the probe is submerged and there is a boundary (surface, side, or bottom) within view.

- a) Hold the FlowTracker2 that the boundary is located approximately 20-30 cm (8-12 in) from the probe.
- b) User may need to add a small amount of fine dirt or other seeding material and stir the bucket well for good test conditions. Regular tap water usually does not have enough scatterers (seeding) for a valid test.

6.3.4 Diagnosing Measurements with Beam Check

Beam Check function can be used to detect measurement conditions and or hardware related issues that can affect the measurement accuracy and precision.

6.3.4.1 Low Scattering Strength

Lack of scattering material in the water normally encountered during measurements at springs or under ice will result in a small or non-existing sampling volume peak (see [Figure 6:4](#)). In cases where there is not sufficient backscatter, place a small amount of seeding material in the water to act as scattering material (see [Seeding](#)).

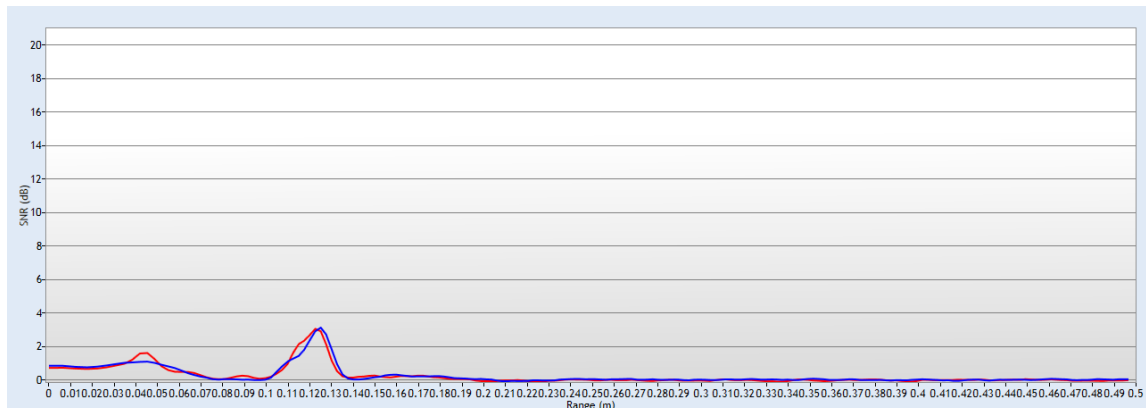

Figure 6:4 - Low Scattering Strength

6.3.4.2 Strong Scattering Strength

Most river systems and or irrigation canals have sufficient scattering material in the water and will result in a well-defined sampling volume peak (see [Figure 6:5](#)).

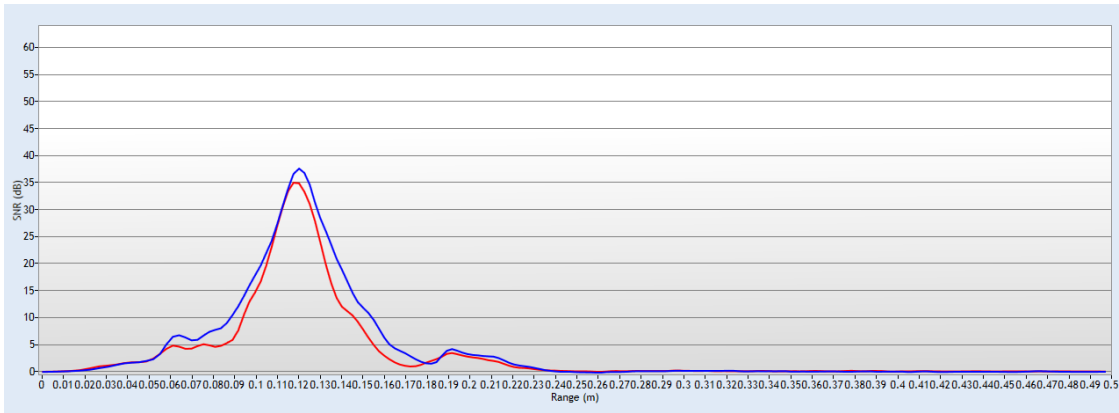

Figure 6:5 - Strong Scattering Strength

6.3.4.3 Boundary Detected within Beam Check

When a boundary is within 50cm from the FlowTracker2 transducer, the boundary will be detected by FlowTracker2 when performing a Beam Check (see [Figure 6:6](#)). The boundary was detected about 40cm away from the transducer

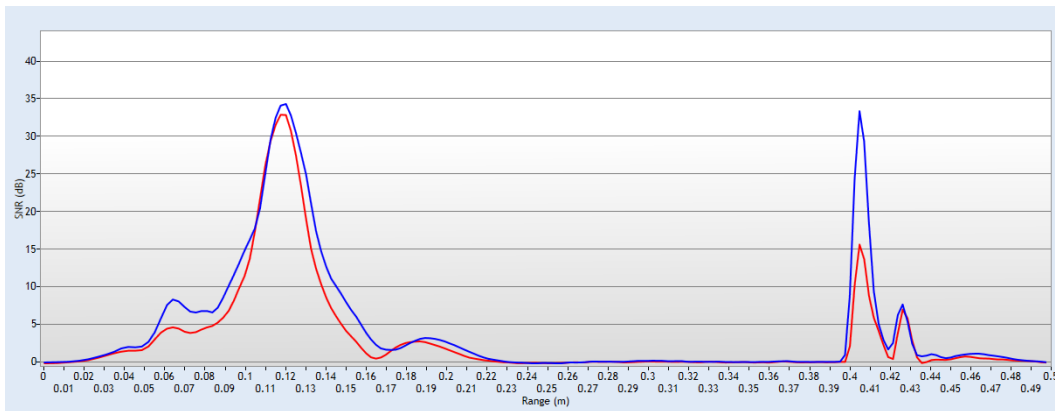

Figure 6:6 - Boundary Detected - 40cm

The Beam Check supplied in [Figure 6:7](#) indicates that boundary was detected at 30cm away from the transducer.

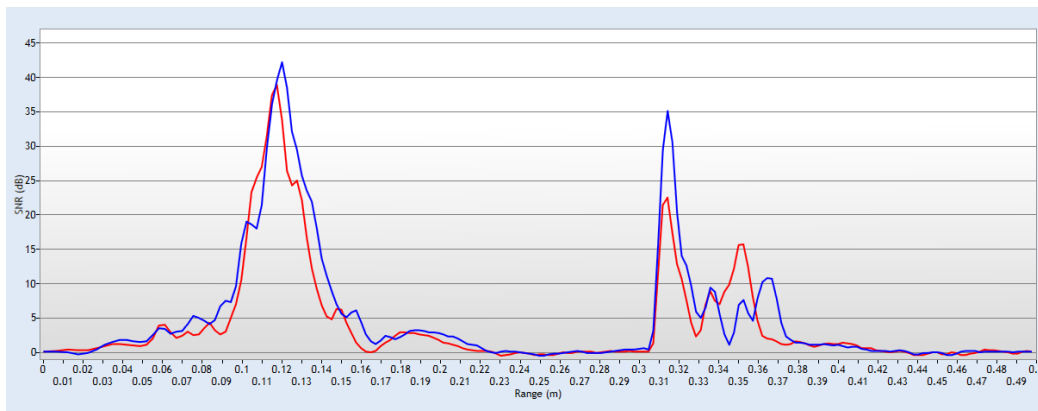

Figure 6:7 - Boundary Detected - 30cm

The Beam Check supplied in [Figure 6:8](#) indicates that boundary was detected at 30cm away from the transducer.

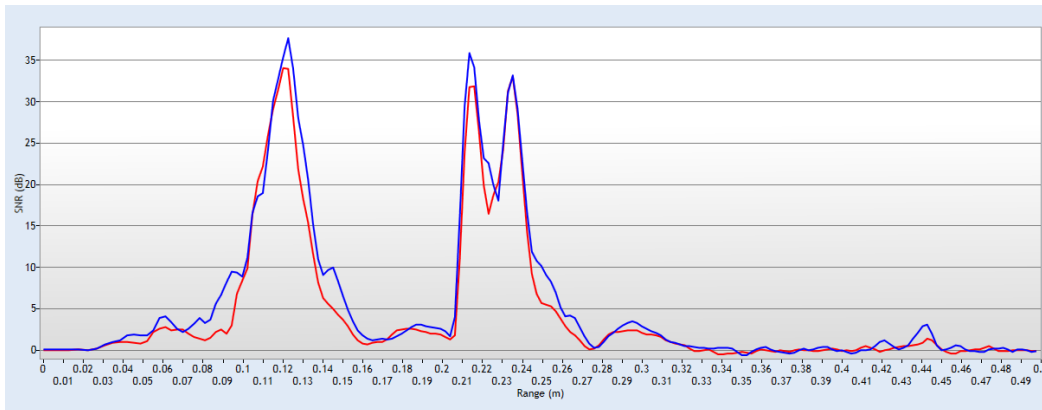

Figure 6:8 - Boundary Detected - 20cm



Boundary that is located within 27cm from the FlowTracker2 transducer can affect the accuracy and precision of velocity measurement. It is recommended when working close to boundaries to determine the location of the boundary in relation to the transducer and sampling volume. This can be achieved by performing a manual Beam Check or Automated Beam Check.

6.3.4.4 Boundary in Sampling Volume

Boundary in Sampling Volume occurs when the boundary is located at the same position from the transducer than the sampling volume. There are number of unique features shown in [Figure 6:9](#) that can be used to identify if boundary is located within the sampling volume.

- a) The SNR of the peak located at the sampling volume is two to three times higher than previous measurements performed.
- b) Three peaks are displayed in the Beam Check, spaced at equal distances.
- c) The SNR of each peak reduces as distance increase form the transducer.

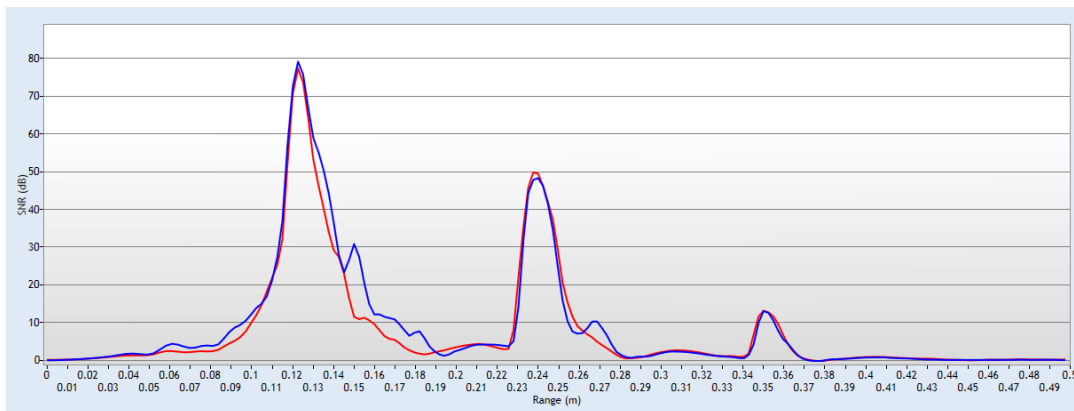

Figure 6:9 - Boundary within Sampling Volume

6.4. Automated Beam Check

The **Automated Beam Check** function allows the user to perform a Beam Check in the region of the measurement section before data collection starts. The automated beam check perform a number of quality control checks on the data collected to determine if the flow conditions are suitable for discharge measurements. The data that is displayed graphically during the Automated BeamCheck is time series of the Quality Control parameters.



The **Automated BeamCheck** is an automated version of Beam Check function described in [6.3 Beam Check](#). In the Original FlowTracker, the Automated Beam Check was known as “Auto QC Test”.

- a) Place the probe in moving water such that the probe is submerged and well away from any underwater obstacles,
 - i). The FlowTracker2 collects data until It has 20 diagnostic samples (not time based),
 - ii). The beam data are analyzed on several criteria outlined in [Table 6:6](#).
- b) The automated beam check quality control criteria used in the evaluation of the beam check data are listed in [Table 6:6](#),

Table 6-6 - Automated Beam Check Quality Control Criteria

Quality Control	Criteria	QC Warning	Graphic Display
Noise Level	<ul style="list-style-type: none"> Measured electronics noise level is compared to reference data. Any significant deviation causes a warning, A large change in noise level may indicate damage to the probe. Noise level supplied in Automated BeamCheck is given in Counts. Multiply with 0.43 to convert to dB. 	Noise Level > QC	
SNR	<ul style="list-style-type: none"> The SNR is checked as sufficient for reliable data collection, Each beam SNR is compared to be sure all beams perform equally, A warning is issued for low SNR < 4 dB, A warning is issued for 4 dB < SNR < 7dB, Beam SNR values differ. 	SNR	

Quality Control	Criteria	QC Warning	Graphic Display
Peak Level	<ul style="list-style-type: none"> The shape of the sampling volume curve is compared to the expected shape. Any significant deviation causes a warning, This criterion can only be checked with sufficient SNR (> 7 dB). 	Peak Level > QC	
Peak Location	<ul style="list-style-type: none"> The physical location of the sampling volume is compared to the expected location. Any significant deviation causes a warning. This criterion can only be checked for sufficient SNR (> 7 dB). 	Peak Location > QC	
Temperature	<ul style="list-style-type: none"> No criteria defined for Temperature. Temperature data included in Automated BeamCheck to allow user to analyze data before measurement. 	None	

- c) The graphical display of the Quality Control parameters supplied during the Automated BeamCheck is time series of each parameter. If there are any significant variation between the beams, spikes are present in the data or Quality Control warnings are issued we recommend the following steps,
- i). Repeat the test at least once, after you verify that the probe and sampling volume are well away from any underwater obstacles.
 - ii). Perform BeamCheck, described in [6.3 Beam Check](#) to evaluate FlowTracker2 performance in more detail,
- d) The display options for individual or all beam check data are listed in [Table 6:7](#). The shortcut key on the keypad determines which beam SNR will be displayed,

Table 6-7 - Automated Beam Check Display

Beam	Line Color	Keypad Key
Beam1	Red	1
Beam2	Blue	2
Beam3	Green	3
All Beams	All	4

- e) *To select a Quality Control Criteria,*
- i). Use up or down scroll arrows keys to view quality control criteria.

Section 7. Measurement Process

The **Measurement Process** involved for performing field measurements using a FlowTracker2 instrument consists of number of components. It is important for both the novice and experienced user that each of the components is followed to ensure that the data collected during the measurement process is within acceptable standards and quality. The main components that is the basis of the overall measurement process are the following,

- Office Procedures,
- Measurement Site Information,
- Pre Measurement Diagnostics,
- Measurement Procedure,
- Post Measurement Requirements.



Components within the Measurement Process should not be neglected due to lack of operational experience, time or workload as this will compromise the data quality and accuracy.

7.1. Office Procedures

The **Office Procedures** lists the steps that need to be performed to confirm the condition and operation of the equipment and accessories before departure for field measurements.



The verification of instruments and accessories before leaving the office is normally neglected. It is highly recommended that instrumentation are inspected and tested before each field measurement exercise.

7.1.1 Equipment List

Equipment List is an essential part in the planning and preparation stages of a field measurement exercise. It is recommended that a comprehensive list is designed based on user and or organizational requirements as this will ensure that all equipment is prepared and packed before departing from the office. The equipment required for field measurements are categorized under FlowTracker2 Instrument and user defined measurement gear.

- a) The FlowTracker2 Instrument and related accessories is detailed under [FlowTracker2 Case](#) section. A reference sheet of the contents is supplied within the FlowTracker2 carry case.
- b) The user defined measurement gear is a list of items required in addition to the FlowTracker2 Instrument to perform a field measurement.

- c) Recommended measurement equipment list containing FlowTracker2 instrument, measurement gear, safety gear and reference instruments are supplied in [Appendix D](#).



The safety gear listed in [Appendix D](#) is only a recommendation. It is imperative that the user follow their respective organization and or local authority guidelines in the use of safety gear during field measurements.

7.1.2 Hardware Inspection

Hardware Inspection can identify any damage to the hardware components that occurred during previous application. It is recommended that the hardware checks listed in [Table 7:1](#) are performed before departure from the office. Any instrument problems experienced as a result of the damage can be resolved by exchanging the hardware components or using a different FlowTracker2 instrument.



The FlowTracker2 probe or handheld can be exchanged with another instrument if required. The software registers the serial number of probe and handheld with each point velocity measurement.

Table 7-1 - Hardware Inspection

Component	Inspection
Handheld	<ul style="list-style-type: none"> Inspect the handheld for any external damage to the housing, LCD screen and keypad, Battery cap and O-ring, Connectors of battery cartridge, USB port.
Probe	<ul style="list-style-type: none"> Mounting between receiver arms and probe body, Scratched transducer face, Dented or bent probe stem.
Probe Cable	<ul style="list-style-type: none"> Kinks or dents in probe cable, Damaged or bent pins on probe cable connector.
Top Setting Rod	<ul style="list-style-type: none"> Bent top setting rod, Bent S bracket or screw.

7.1.3 Office Diagnostic

Office Diagnostic is a basic verification process of the FlowTracker2 to confirm that the instrument is operational before departure from the office. The diagnostic tests consist of the evaluation of a number of functions to verify the internal operations and probe performance of the FlowTracker2.

- The functions that are evaluated during diagnostic test process are located under the [Utilities](#) menu.
- The diagnostic test process is mainly categorized under Internal Systems, Raw Data and Beam Check functions.

- i). Internal System functions comprise of internal clock, recorder, battery and GPS data. These functions can be verified manually by evaluating the information displayed or using external reference if required.
- ii). Raw data function includes Velocity, SNR, Temperature, Battery and Tilt data that is graphically displayed. These functions can be verified by manually interpreting the information displayed or against a reference instrument.



The velocity data displayed under Raw Data for the Office Diagnostic tests should be ignored as the data is not based on actual measurements conditions.

- iii). Beam Check function is performed to verify the FlowTracker2 probe performance. The procedure for performing a Beam Check must be followed as stipulated in [Beam Check Operation](#).
- c) *To verify* the GPS Data functions place the FlowTracker2 handheld outside in an open area with a clear view of the sky. The accuracy of the GPS data is directly related to the number of satellites and HDOP value.
- d) *To verify* the Raw Data and Beam Check functions place the FlowTracker2 probe in a bucket of water (see [Beam Check Operation](#)).
- e) The variables that are evaluated during the diagnostic tests are listed in [Table 7:2](#).

Table 7-2 - Office Diagnostics

Function	Variable	Verification
System Clock	<ul style="list-style-type: none"> • Date • Time • UTM Offset 	<ul style="list-style-type: none"> • System Clock function show the current internal time of the FlowTracker2 instrument, • Verify if the internal system clock date and time is correctly set and adjust if required.
Recorder	<ul style="list-style-type: none"> • Memory Available 	<ul style="list-style-type: none"> • The Recorder function indicates the percentage of available memory, • If the available memory is insufficient download all measurement files. Ensure that all measurement files downloaded are stored in a secure area, • Format Recorder or delete Data Files to increase available memory.
Battery Data	<ul style="list-style-type: none"> • Battery Type • Percentage Full 	<ul style="list-style-type: none"> • Battery Data function display the type of battery, voltage and percentage full, • Make sure the correct battery type is selected.
GPS Data	<ul style="list-style-type: none"> • Latitude • Longitude • Altitude • Date • Time 	<ul style="list-style-type: none"> • The GPS Data function displays the GPS information from the internal GPS, • Compare GPS data supplied with external reference such as Survey Bench Mark, handheld GPS or mobile device equipped with GPS.
Raw Data Display	<ul style="list-style-type: none"> • Velocity • SNR • Temperature • Tilt • Battery Indicator 	<ul style="list-style-type: none"> • The Raw Data function display raw data for each variable, • Evaluate each variable data that are graphically displayed or compare against a reference instrument in the case of temperature measurements,
Automated	<ul style="list-style-type: none"> • Peak Level 	<ul style="list-style-type: none"> • The Automated Beam Check and Beam Check

Function	Variable	Verification
Beam Check	<ul style="list-style-type: none"> • Peak Position • Peak Location 	functions serve two purposes, verifying the probe performance and measurement conditions, <ul style="list-style-type: none"> • Evaluate the Quality Control reports supplied during the test.
Beam Check		

7.2. Measurement Site Information

Measurement Site Information, commonly referred to as “*Metadata*”, should be documented before any measurements are performed with the FlowTracker2 instrument. In most organizations, FlowTracker2 measurements are related to a measurement site and secondary data sets and it’s essential that the information collected is accurate. The measurement site information that should be collected during a field measurement exercise is listed in [Table 7:3](#).



Unique entry fields were developed in the FlowTracker2 software for the measurement site information defined in this section. The dedicated fields ensure that information is captured correctly and assigned to respective variables, which promote good data management practices.

Table 7-3 – Measure Site Information

Variable	Description	Unique Field
Site Number	Site number allocated to measurement site. Most organizations use a unique number system (e.g. associated with catchment).	File Properties
Site Name	Site name allocated for measuring site. Most organizations use a unique naming convention (e.g. combination of river and place name).	File Properties
Operator	Operator that performed the measurement	File Properties
Start Date and Time	Start date and time of measurement.	Internally recorded
End Date and Time	End date and time of measurement.	Internally Recorded
Start Staff Gauge Readings	Staff gauge reading taken before a FlowTracker2 measurement is performed.	Supplemental Data
End Staff Gauge Readings	Staff gauge reading taken after a FlowTracker2 measurement is completed.	Supplemental Data
GPS Position	GPS position of start and end location of measurement	Internally Recorded
Photographs	Photographs of the measurement section, upstream conditions and downstream conditions are essential for identifying possible influences on the field measurements.	None



Organizations that make use of hydrological databases, unique monitoring site identifiers and import routines, would find the Site Number very useful to automatically link the data to a specific monitoring site during the import process.

7.3. Pre Measurement Diagnostics

Pre Measurement Diagnostics is an essential step in the measurement process to ensure accurate and consistent measurement results. The functions evaluated in pre-measurement diagnostics are the same as discussed in *Office Diagnostics*.

- a) The functions that are evaluated during diagnostic test process are located under the [Utilities](#) menu.
- b) The functions that are of key importance during the pre-measurement diagnostic tests are System Clock, Velocity Data, SNR Data and Beam Check functions.
- c) It is recommended that Pre Measurement Diagnostics should be performed before each measurement is started.
- d) *To verify* the Internal System, Raw Data and Beam Check functions place the FlowTracker2 probe in moving water well away from any underwater obstacles in the region of the measurement section.
- e) The variables that are evaluated during the diagnostic tests are listed in [Table 7:4](#).

Table 7-4 - Pre Measurement Diagnostics

Function	Verification
System Clock	<ul style="list-style-type: none"> • Verify if the internal system clock date and time is correctly set and adjust if required. • All data sets recorded during a FlowTracker2 measurement receive a date and time stamp, • Date and Time is essential Metadata in the processing and application of measurement results.
Recorder	<ul style="list-style-type: none"> • Verify if the available memory is sufficient for performing a measurement, • Insufficient memory on the recorder could affect the measurement operation and or recording of measurement file.
Battery Data	<ul style="list-style-type: none"> • Evaluate the battery voltage and capacity based on the battery type selected, • Insufficient power supply could affect the measurement operation.
GPS Data	<ul style="list-style-type: none"> • Evaluate the GPS information received, with the focus on number of satellites, and HDOP values. This will indicate the level of accuracy of the GPS measurement.
Raw Data Display	<ul style="list-style-type: none"> • The raw data displayed of all variables is updated once per second. • Velocity, data should appear reasonable for the environment (short term variations are expected and are most likely real). • SNR, data should ideally be above 10 (units are dB), but measurements can be made as low as 3-4 dB. • Temperature, data should reasonable to the environment. Temperature data is used for sound speed calculations and can affect velocity data (see Principle of Operations).
Automated Beam Check	<ul style="list-style-type: none"> • Place the probe in moving water well away from any underwater obstacles; follow the on screen instructions for the test. Perform Beam Check measurement as described in Beam Check Operation. • Automated Beam Check, review of Automated Beam Check results see Automated Beam Check, • Beam Check, review of Beam Check results see Beam Check.
Beam Check	

7.4. Measurement Procedure

The basic outline of the **Measurement Procedure** required to perform a Discharge measurement with a FlowTracker2 instrument is supplied in the following section. The measurement procedure is based on wading principles, which is suited for low to medium flow conditions depending on water velocity and depth.

- a) Collect and verify Measurement Site Information before discharge measurement commences as stipulated under [Measurement Site Information](#).
- b) Select the measurement site based on the criteria stipulated under [Site Selection Requirements](#). Site and flow conditions does change over time and it is recommend that existing measurement site is evaluated during each field measurement exercise.
- c) It is recommended for new measurement sites that the user perform spot checks across the section at certain locations to get an estimation of the velocity range, water depth and channel geometry.
- d) Perform Pre Measurement Diagnostic tests in the region of the proposed measurement section. Place the probe in moving water well away from any underwater obstacles.
- e) A graduated tagline or measuring tape should be spanned across the measurement section to determine the station location. The graduated tagline or measuring tape should be perpendicular to the main flow direction and channel orientation.
- f) Staff gauge readings with time should be taken at the start the discharge measurement. If the discharge measurement is over extended period or at a measurement site with rapid changing stage, intermediate readings should be taken.
- g) Enter Rated discharge (if applicable) of measurement site to calculate percentage flow of each panel.
- h) Divide the measurement section into a minimum of 23 stations (for sections >5m). The number of stations required is dependent on the measurement section width (see [ISO 748 – 2007, Hydrometry - Measurement of liquid flow in open channels using current meters or floats](#) for recommendation of number of stations). The flow per panel should not exceed 10% of the total flow, with 5% as the ideal distribution.
- i) The water depth at each station is measured using a top setting or universal rod. A staff gauge board can also be used to determine the water depth at the location of the station or sampling volume of the FlowTracker2.
- j) The averaging time interval for data collection normally varies between 40 to 60 seconds for velocity measurements depending on flow conditions.

- k) **Determining Mean Station Velocity** method for each station. The software suggests either a six-tenths or two-point method depending on the threshold in **0.6 Method Depth** and the measured water depth. The minimum distance between the channel bed and water surface and instrument must be within the instrument specifications.
- l) The FlowTracker2 must be perpendicular to the graduated tagline or measuring tape that was setup across the measurement section.

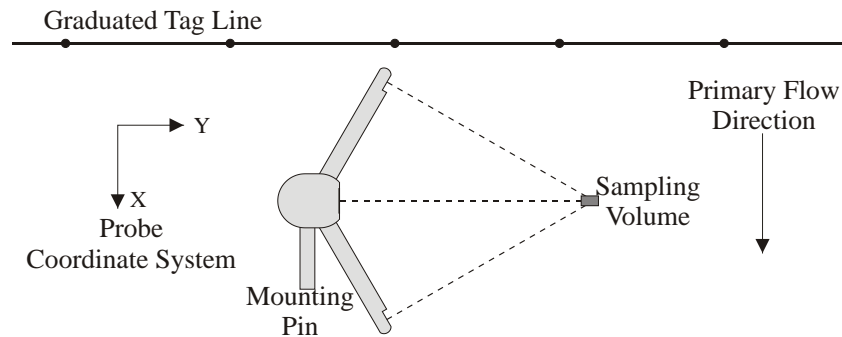

Figure 7:1 - FlowTracker2 Probe Orientation Relative to Stream Flow

- m) Keep the FlowTracker2 probe free of plant material at all times as this can impact the velocity measurements significantly.
- n) Continuously evaluate the measurement results with measurements performed at previous stations. The variation in measurement results should reflect the flow conditions at the measurement site.
- o) Review the instrument configuration during the measurement, especially the quality control parameters and adjust if required.
- p) Automated Beam Check can be performed during any stage of the measurement to verify the probe performance and measurement conditions.
- q) Comments can be entered at each station or at the end of the discharge measurement to describe the flow conditions or any influences that may impact the measurement quality.
- r) Staff gauge reading with time should be taken at the end of the discharge measurement.

7.5. Post Measurement Requirements

Post Measurement Requirements consist of number of tasks that need to be performed when a field measurement is completed. The tasks that form the framework of the post measurement requirements are grouped under the following main categories,

- Review of Measurement Site Information,
- Review Measurement Summary
- Data Management,

- Storage.

7.5.1 Review of Measurement Site Information

Review of Measurement Site Information before departing from the measurement site is important to ensure that all associated Metadata is accurate. It is recommended that the user verify each variable populated during the measurement process with the main focus on the measurement site reference.



It is not good data management practice to leave both measurement site references empty or with abbreviate terms. It is recommended that the user makes use of accurate site descriptions.

7.5.2 Review Measurement Summary

Review Measurement Summary is the evaluation of the measurement results and if the results are expected from the flow conditions present at the measurement site. There are a number of variables that can be evaluated after the measurement is completed and it is recommended that the following process is followed during the evaluation.



The evaluation of measurement results should be performed during the measurement and the review of measurement summary is just an overview of what was already identified during a measurement. It is recommended to repeat a point velocity or station measurement if any of the data collected during a measurement are not consistent with the flow conditions present.

- a) Point velocity measurements with regard to mean velocity, standard error and quality control reports correspond within a station measurement and adjacent stations.
- b) Station measurements with regard to location, depth, mean velocity and panel discharge correspond to adjacent stations and what is expected from the flow conditions.
- c) The total width based on station locations does that correspond with the actual width of the measurement section.
- d) The total discharge, area and mean velocity measured is within the expected flow conditions.
- e) Review measurement results against historical measurements performed at the measurement site during similar flow conditions and or staff gauge readings (if available).
- f) Review total discharge measured against discharge reading from developed Stage - Discharge Relationship (if available). Most organizations use a 5% error band to determine if the measurement results are within the required measurement standards.



The review process is a key component of overall data quality and it is recommended that this process be completed in the field directly after the measurement. Most organizations supply their hydrographers or hydrologists a copy of hydrological

database or other data formats to perform this process in the field.

7.5.3 Data Management

Data Management consists of the process involved in managing the information collected during field measurements. The steps required to ensure data continuity and safe keeping after field measurements are completed are the following.

- a) Download measurement files after measurements are completed at the measurement site or by the end of the work day using the FlowTracker2 desktop software. The files types created during a measurement are dependent if a measurement and or Beam Check tests were performed. For more information on file types see [Table 4:2](#).
- b) Create a secondary backup of the measurement files at the end of each workday by copying the files to an external USB drive. The USB drive should be stored separately from the PC or Tablet.
- c) Photographs taken with Camera or Phone during the field measurements should also be downloaded and stored on an external USB drive.



The internal recorder of the FlowTracker2 handheld should not be used as the main storage device for safe keeping of measurement files. It is good data management practice to download the measurement files at least once per day.

7.5.4 Storage

Storage guidelines of FlowTracker2 instrument and accessories are essential to ensure the safe keeping of the instrument during transport or storage at the office. The FlowTracker2 instrument is supplied in a pelican case with foam inserts, designed to house each individual component. The recommend guidelines for packing of instrument in the pelican case are the following,

- a) Place each component of the FlowTracker2 and accessories in the designated foam inserts.
- b) The probe cable must be disconnected form the handheld before it is placed in the foam inserts.
- c) The probe cable should be coiled in such a manner that it fits into the designated insert. Care should be taken that the cable is not kinked or the pelican case lid is pressing on the cable.
- d) Battery cartridge should be removed from the handheld by the end of each workday. In the case where the FlowTracker2 instrument is not used, it is recommended that the batteries are removed from the pelican case.



Batteries should not be left in the FlowTracker2 handheld for prolonged periods as damage can occur to the handheld if the batteries are leaking. It is recommended that batteries are removed from the handheld if the instrument is not used.

Section 8. Discharge Measurement

Discharge Measurement is the measurement technique involved in collecting data for discharge calculation based on the Discharge Mode (see [Data Collection Modes](#)). The data collection framework for discharge measurement is a well-designed workflow (see [Software Flow Diagram](#)) between setting up of measurements parameters, creating a measurement section, the collection of raw data and generating individual station and measurement section reports. The discharge data collection process consists of the following main components, with discussions of each component.

- Create Measurement,
- Automated Beam Check,
- Data Collection,
- Discharge Summary.

8.1. Create Measurement

Creating a new measurement consists of a number of steps before the data collection can be performed. The first step involved is to either select an existing [Configuration Template](#) or create a new template with user defined configuration parameters. The template then needs to be associated with a measurement file that is created by the user. When the measurement file is created, the software is ready for data collection.

8.1.1 Measurement

The **Measurement** function enables the user to create a new measurement in either Discharge or General mode. The Discharge mode used for the collection of discharge data during field measurements will be focused on in this section.

- a) The Measurement function can be accessed from the Main Menu on the bottom banner,
- b) *To select the Measurement function,*
 - i). Press the Right Soft Key.
- c) *The software will Navigate to the New File Type or Mode screen.*

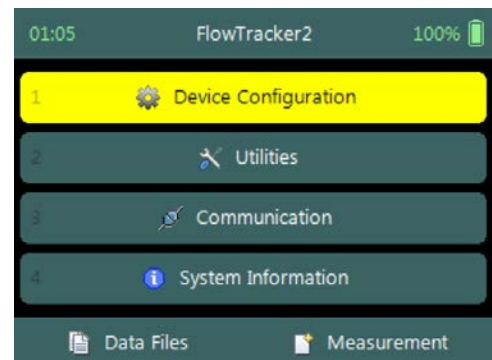

Figure 8:1 - Main Menu

8.1.2 New File Type

The **New File Type** function enables the user to determine if the new measurement file should be based on either Discharge or General mode.

The **New File Type** screen consists of the following options,

- a) Discharge,
- b) General,
- c) *To select discharge mode,*
 - i). Use up or down scroll arrows keys to select Discharge and press enter key.
- d) *The software will Navigate to the New File Template screen.*
- e) *To navigate to Home menu,*
 - i). Press the Left Soft Key.

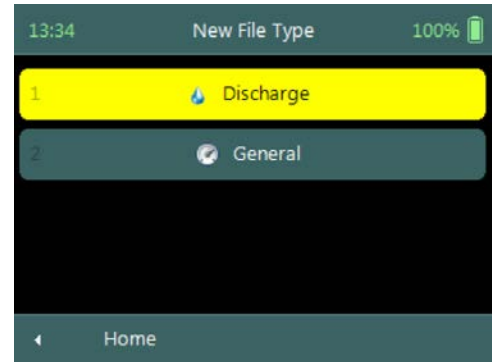

Figure 8:2 - New File Type

8.1.3 New File Template

New File Template function enables the user to create a new configuration template based on SonTek default settings or select an existing [Configuration Template](#) created by the user. The configuration template is based on user defined parameters that are dependent on measurement site details, flow conditions and organizational requirements. The configuration template selected will be assigned to the measurement file and the parameters defined in the template will be applied during the Discharge measurement.

The **New File Template** screen consists of the following options,

- a) **(default)**, the template will be based on SonTek default settings.
- b) [Configuration Templates](#), created under “Device Configuration”. A list of available templates created by the user will be displayed under the “(default)” option.
- c) *To select a template,*
 - i). Use up or down scroll arrows keys to select template and press enter key.
- d) *The software will navigate to the New Data File screen.*
- e) *To navigate to File Type menu,*
 - i). Press the Left Soft Key.

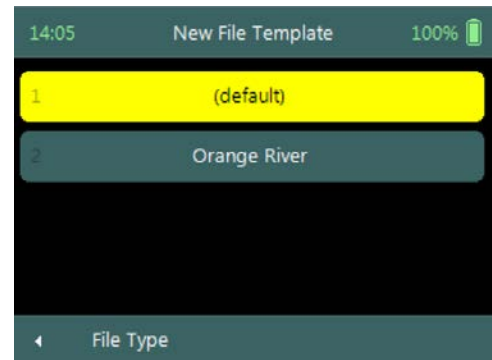

Figure 8:3 - New File Template

8.1.4 New Data File

New Data File function enables the user to populate the measurement site and operator details. The information entered for each parameter should be accurate as this

information is recorded in each measurement file and used in both the [File Naming](#) and [Folder Naming](#) conventions.

- Existing templates created under “Device Configuration”, parameters will be prepopulated from [File Properties](#) information that was captured,
- Templates based on SonTek default configuration will have no information populated and the user will need to enter the required details for each parameter.



It is not good data management practice for both measurement site references to be empty or with abbreviate terms. It is recommended that the user makes use of accurate site descriptions.

The **New Data File** screen consists of the following parameters,

- Site Number,
 - Site Name,
 - Operator,
 - Comment.
- To *select* a parameter,
 - Use up or down scroll arrows keys to select a parameter.
 - To *accept* the new data file configuration,
 - Press the Right Soft Key,
 - The software will navigate to Automated Beam Check screen.
 - To **CANCEL** new data file configuration,
 - Press the Left Soft Key,
 - The software will return to New File Template.

Figure 8:4 - New Data File

8.2. Automated Beam Check



Duplicate of [6.4 Automated Beam Check](#)

The **Automated Beam Check** function allows the user to perform a Beam Check in the region of the measurement section before data collection starts. The automated beam check perform a number of quality control checks on the data collected to determine if the flow conditions are suitable for discharge measurements. The data that is displayed graphically during the Automated BeamCheck is time series of the Quality Control parameters.



Automated BeamCheck is an automated version of Beam Check function described in [6.3 Beam Check](#). In the Original FlowTracker, the Automated Beam Check was known as “Auto QC Test”.



Automated Beam Check can be performed during any stage of the data collection process. The Automated Beam Check functions are available before data collection start and during velocity measurement from the “Data Collection Menu” (see [Data Collection Screen](#)).

8.2.1 Start Automated Beam Check

The FlowTracker2 probe should be placed in the region of the measurement section in moving water such that the probe is submerged and well away from any underwater obstacles. The FlowTracker2 collects data for about 20 seconds.

The **Automated Beam check** screen shows the steps involved in performing an automated beam check.

- a) To **start** the automated beam check,
 - i). Press the Left Soft Key.
- b) To **CANCEL** automated beam check,
 - i). Press the Right Soft Key,
 - ii). The software will navigate to Data Collection window.
- c) To **accept** Automated Beam Check,
 - i). Press the Right Soft Key,
 - ii). The software will navigate to the Data Collection window.

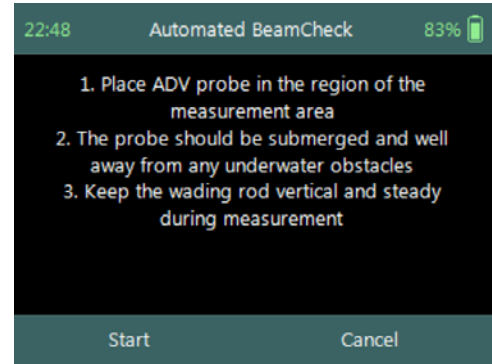

Figure 8:5 - Automated Beam Check

8.2.2 Evaluate Beam Check Results

The automated beam check quality control criteria used in the evaluation of the beam check data are listed in [Table 8:1](#),

Table 8-1 - Automated Beam Check Quality Control Criteria

Quality Control	Criteria	QC Warning	Graphic Display
Noise Level	<ul style="list-style-type: none"> • Measured electronics noise level is compared to reference data. Any significant deviation causes a warning, • A large change in noise level may indicate damage to the probe. • Noise level supplied in Automated BeamCheck is given in Counts. Multiply with 0.43 to convert to dB. 	Noise Level > QC	

Quality Control	Criteria	QC Warning	Graphic Display
SNR	<ul style="list-style-type: none"> The SNR is checked as sufficient for reliable data collection, Each beam SNR is compared to be sure all beams perform equally, A warning is issued for low SNR < 4 dB, A warning is issued for 4 dB < SNR < 7dB, Beam SNR values differ. 	SNR	
Peak Level	<ul style="list-style-type: none"> The shape of the sampling volume curve is compared to the expected shape. Any significant deviation causes a warning, This criterion can only be checked with sufficient SNR (> 7 dB). 	Peak Level > QC	
Peak Location	<ul style="list-style-type: none"> The physical location of the sampling volume is compared to the expected location. Any significant deviation causes a warning. This criterion can only be checked for sufficient SNR (> 7 dB). 	Peak Location > QC	
Temperature	<ul style="list-style-type: none"> No criteria defined for Temperature. Temperature data included in Automated BeamCheck to allow user to analyze data before measurement. 	None	

- a) The graphical display of the Quality Control parameters supplied during the Automated BeamCheck is time series of each parameter. If there are any significant variation between the beams, spikes are present in the data or Quality Control warnings are issued we recommend the following steps,
- i). Repeat the test at least once, after you verify that the probe and sampling volume are well away from any underwater obstacles.
 - ii). Perform BeamCheck, described in [6.3 Beam Check](#) to evaluate FlowTracker2 performance in more detail,
- b) The display options for individual or all beam check data are listed in [Table 8:2](#). The shortcut key on the keypad determines which beam SNR will be displayed,

Table 8-2 - Automated Beam Check Display

Beam	Line Color	Keypad Key
Beam1	Red	1
Beam2	Blue	2
Beam3	Green	3
All Beams	All	4

c) *To select a Quality Control Criteria,*

i). Use up or down scroll arrows keys to view quality control criteria.

8.3. Data Collection

Data Collection function for Discharge mode is the process involved in collecting data during a discharge measurement. The data collection process is a systematic workflow designed to follow the actual measurement process in the field. The process consist of the following main components that also describes each individual aspect of the field measurement,

- Data Collection Window,
- Station Types,
- Station Measurement,
- Data Collection Menu.

8.3.1 Data Collection Window

The **Data Collection Window** can be defined as the “*control center*” of the data collection process during a discharge measurement. All the software functions required to perform a discharge measurement is available from the data collection screen. The key features of the data collection window are explained in [Figure 8:6](#).

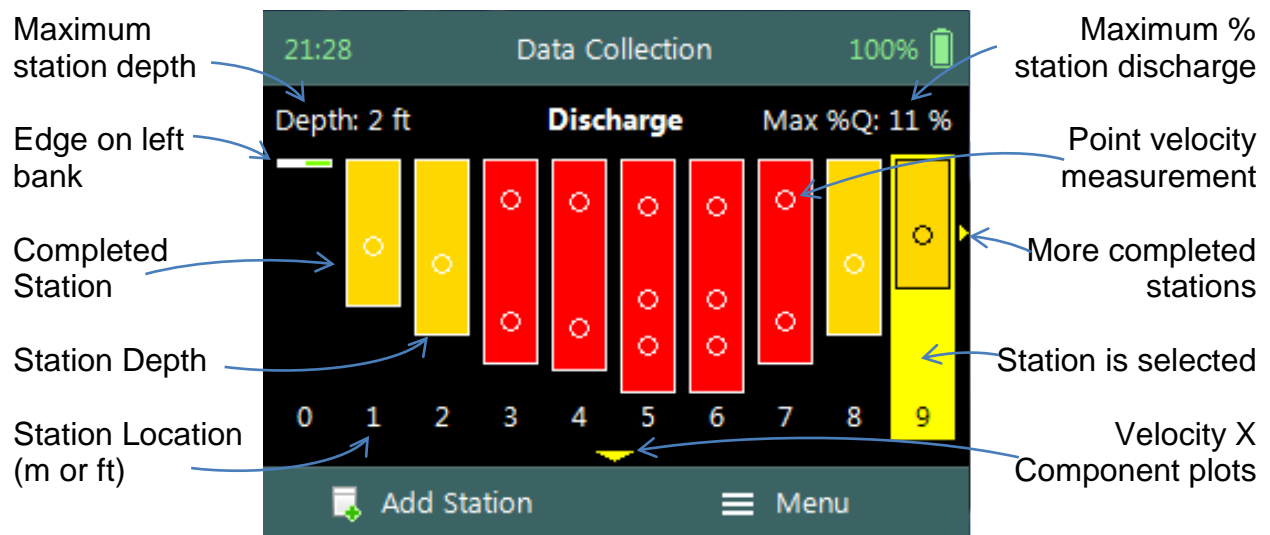

Figure 8:6 - Data Collection Window

The operations and functions available of the Data Collection Window will be discussed throughout this section with the main functions described in [Figure 8:7](#).

Data Collection Window screen of the consists of the following,

- a) Station Management area defined in [rectangle](#),
- b) Add Station,
- c) Data Collection Menu (*Menu*).
- d) To **add** a station,
 - i). Press the Left Soft Key.
- e) To **select** the data collection **menu**,
 - i). Press the Right Soft Key,
 - ii). The software will display a popup menu screen.

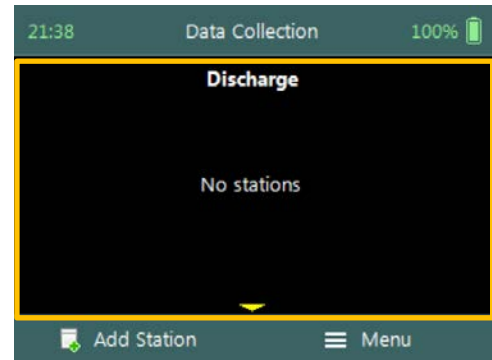

Figure 8:7 - Functions Data Collection Window

8.3.1.1 Add Station

The **Add Station** function allows the user to add a station to the measurement section based on the station types defined for Discharge Measurement technique. The parameters required for creating a station is defined by the station type as discussed under [Station Types](#). There are several common parameters that are applicable to all station types of which are listed below.

Add Station screen consist of the following common parameters that are required for all station types,

- a) Location,
- b) Depth,
- c) Station Type,
- d) Correction Factor,
- e) Comment.

The standard **functions** available for each station type are,

- f) Add Gauge Height,
- g) Record GPS Location (function availability, see [GPS Station Tagging](#)).
- h) To **add** a station or start velocity measurement,
 - i). Press the Right Soft Key.
- i) To **CANCEL** add station,
 - i). Press the Left Soft Key.

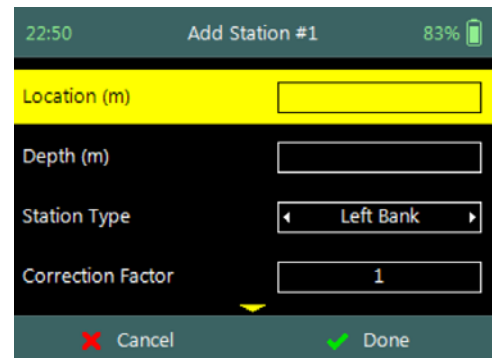

Figure 8:8 - Add Station

8.3.1.2 Delete Station

Deleting a station is performed from the **Data Collection Window** by selecting the station within the viewable window.



The station delete process is not reversible and the user must ensure that the correct station is selected. Selected station will be highlighted with a yellow background.

Delete Station is performed from the **Data Collection Window**. Up to ten completed stations will be displayed at any time,

- a) *To select a station,*
 - i). Use the left or right arrow key to scroll through the completed stations,
- b) *To **DELETE** a station,*
 - i). Press the backspace key.
 - ii). The software will navigate to the Confirmation screen.

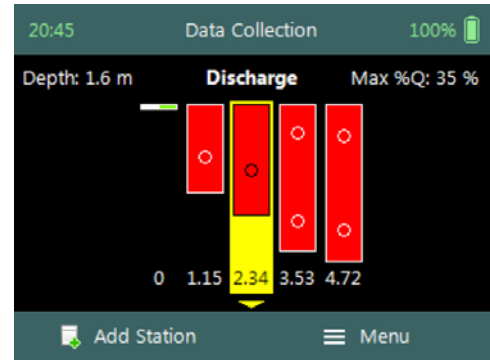

Figure 8:9 - Select Station

Confirmation screen requests confirmation of deleting the selected station by the FlowTracker2 handheld software.

- a) *To **confirm** station delete,*
 - i). Press the Right Soft Key,
- b) *To **CANCEL** station delete,*
 - i). Press the Left Soft Key,
- c) *The software will navigate to the Data Collection Window.*

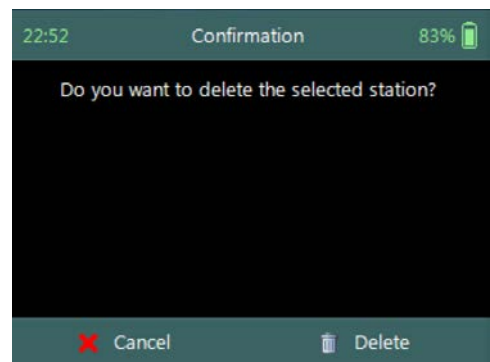

Figure 8:10 - Confirm Delete

8.3.1.3 Edit Station

Editing the station parameters can be performed from the **Data Collection Window** by selecting the station within the viewable window. The station editing process allows the user to change all the parameters original configured when the station was created from the “Add Station” screen.



Editing should not be performed on the **Velocity Method** after extended time has passed since the initial point velocity measurements were performed. The flow conditions could change during the lapsed time and additional point velocity measurements will not be representative. It's recommended that all the station measurements be repeated if additional measurements are required.

Step 1

Open Station is performed from the **Data Collection Window**. Up to ten completed stations will be displayed at any time,

- a) To *select* a station,
 - i). Use the left or right arrow key to scroll through the completed stations,
- b) To *open* a station,
 - i). Press the enter key.
- c) *The software will navigate to the Review Station screen.*

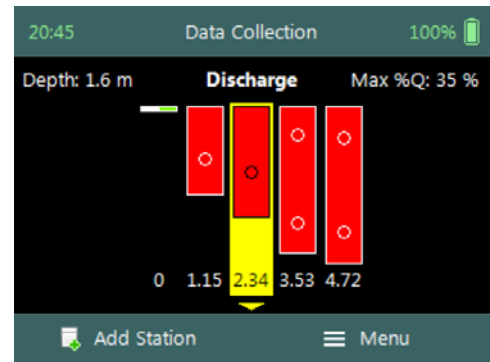
**Figure 8:11 - Open Station****Step 2**

Review Station screen display summary of the selected station. The review station allows the user to review the measurement results before editing is performed.

- a) To *EDIT* station,
 - i). Press the Left Soft Key.
- b) To *close* review station or *CANCEL* edit station,
 - i). Press the Right Soft Key.

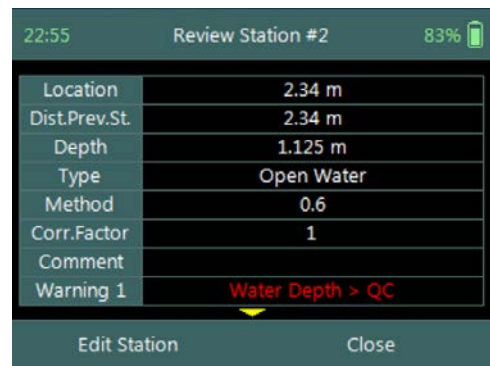
**Figure 8:12 - Review Station****Step 3**

Edit Station screen allows the user to change parameters during the original configuration. The “Edit Station” screen is similar to the “Add Station” screen.

- a) To *confirm* edit station,
 - i). Press the Right Soft Key.
- b) To *CANCEL* edit station,
 - i). Press the Left Soft Key.

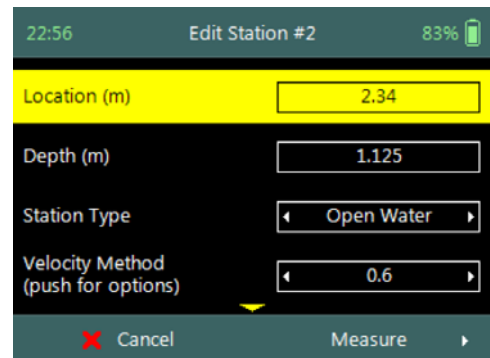
**Figure 8:13 - Edit Station****Step 4**

Confirmation screen request confirmation of discarding all incompatible point velocity measurements by the FlowTracker2 handheld software.

- a) To *confirm* discarding incompatible point velocity measurements,
 - i). Press the Right Soft Key.
- b) *The software will navigate to the Data Collection*

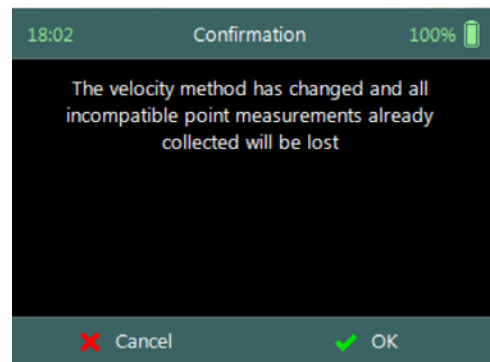
**Figure 8:14 - Confirmation**

Window.

Discarding Measurements

- c) To **CANCEL** incompatible point velocity measurements delete,
 - i). Press the Left Soft Key.



When changes are made to the Velocity Method and Station Type, existing point velocity measurements will be lost if the velocity method is incompatible with the proposed selection.

Some scenarios of velocity measurements that could be affected if changes are made to the Velocity Method and or Station Type are listed in [Table 8:3](#).

Table 8-3 - Incompatible Velocity Methods and Station Types

Parameter	Configuration		Compatibility Result
	Initial	Proposed	
Velocity Method	0.6	0.2 / 0.8	0.6 Measurement will be discarded. The 0.2 / 0.8 measurements must be performed.
Velocity Method	0.6	0.2 / 0.6 / 0.8	0.6 Measurement will remain. The 0.2 / 0.8 measurements must be performed.
Velocity Method	0.2 / 0.8	0.6	0.2 / 0.8 Measurements will be discarded. The 0.6 measurement must be performed.
Station Type	Open water	Edge	All velocity measurements will be discarded. Edge station type is assigned a “none” velocity method.



The deleting of incompatible point velocity measurements is not reversible and the user must be certain of the decision in changing the Velocity Method and or Station Type.

8.3.2 Station Types

The **Station Types** developed for the Discharge Measurement technique provide practical solutions for the different measurement scenarios that exists during field measurements. There are several common parameters that are applicable to all station types. There are also specific parameters, unique to each station type, that will be discussed in this is section. The station types implemented for the discharge measurement are the following,

- Bank (left or right),
- Island Edge,
- Open Water,
- Ice.

8.3.2.1 Bank (left or right)

The **Bank** station type is used to create a station for both the left and right banks. The one noticeable difference between the Bank station type and other station types is the fact that no velocity measurement is performed. The Discharge Calculation Methods implements a zero velocity on the bank when the depth is zero or against a boundary in the case of vertical bank based on hydraulic principles.

Bank station type parameters available on the **Add Station** screen consists of the following,

- a) Location,
- b) Depth,
- c) Station Type,
- d) Correction Factor,
- e) Comment.
- f) *To select a station type,*
 - i). Use the left or right arrow key to scroll through the station types,
- g) *To **add** bank station,*
 - i). Press the Right Soft Key.
- h) *To **CANCEL** add bank station,*
 - i). Press the Left Soft Key.

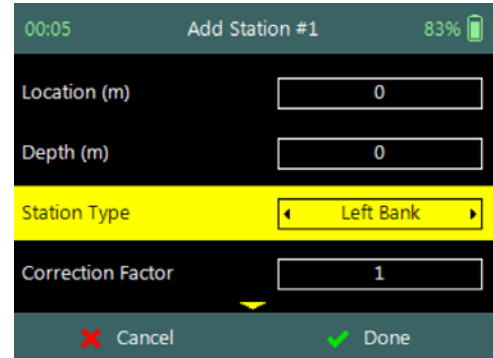

Figure 8:15 - Bank Station Type

Properties associated with the parameters for bank station type are defined in [Table 8:4](#),

Table 8-4 - Bank Station Type - Properties

Parameter	Min	Max	Default	Decimals	Units	Required
Location	-1000	1000	empty	3	m or ft	Yes
Depth	0	100	empty	3	m or ft	Yes
Station Type			Left Bank			Yes
Correction Factor	-1	1	empty	2		Yes
Comment	0	250	empty			No



The Left Bank will always be displayed on the left side of the Data Collection Window independent on which bank the measurement was started. If the measurement was started on the left bank the data collection window will be populated from the left, if the measurement was started on the right bank, the window will be populated from the right.

8.3.2.2 Island Edge

The **Island Edge** station type is used to create a station for Island Edges. Similar to Bank station types, the one noticeable difference between Island Edge station type and other station types is the fact that no velocity measurement is performed. The Discharge

Calculation Methods assumes that the velocity on the bank is zero when the depth is zero or against a boundary in the case of vertical bank.

Island Edge station type parameters available on the **Add Station** screen consists of the following,

- a) Location,
- b) Depth,
- c) Station Type,
- d) Correction Factor,
- e) Comment.
- f) *To select a station type,*
 - i). Use the left or right arrow key to scroll through the station types,
- g) *To add island edge station,*
 - i). Press the Right Soft Key.
- h) *To CANCEL add island station,*
 - i). Press the Left Soft Key.

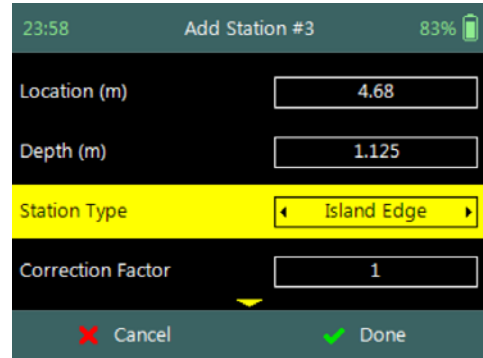

Figure 8:16 - Island Edge Station Type

Properties associated with the parameters for island edge station type are defined in [Table 8:5](#),

Table 8-5 - Island Edge Station Type - Properties

Parameter	Min	Max	Default	Decimals	Units	Required
Location	-1000	1000	empty	3	m or ft	Yes
Depth	0	100	empty	3	m or ft	Yes
Station Type			Island Edge			Yes
Correction Factor	-1	1	empty	2		Yes
Comment	0	250	empty			No



The Island Edge station type is normally selected after “Open Water” or “Ice” station types. The station type after the first Island Edge is completed will be set to “Island Edge” by default. The station type after the second Island Edge is completed will be set to “Open Water” by default.

8.3.2.3 Open Water

The **Open Water** station type is used to create a station for open water conditions, performing velocity measurements within a vertical at a station. Open Water is the main station type that will be used during most discharge measurements and the number of stations required is 23 stations for measurement sections wider than 5m.



The number of stations recommended based on measurement section width are available in the following literature,

- ISO 748 – 2007, Hydrometry - Measurement of liquid flow in open channels using

current meters or floats,

- WMO-No. 1044, Volume I – Fieldwork, 2010.

Open Water station type parameters available on the **Add Station** screen consists of the following,

- Location,
 - Depth,
 - Station Type,
 - Velocity Method,
 - Correction Factor,
 - Comment.
- g) *To select a station type and or velocity method,*
- Use the left or right arrow key to scroll through the station types and or velocity methods,
 - To add open water station and continue to velocity measurement,*
 - Press the Right Soft Key.
- i) *To CANCEL add open water station,*
- Press the Left Soft Key.

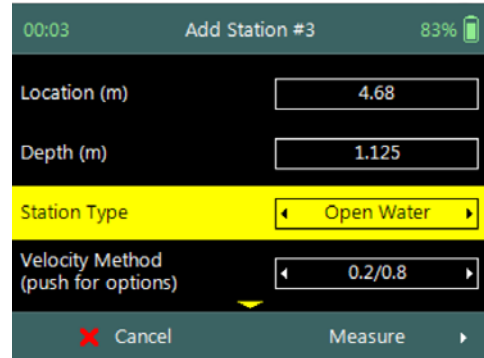



Figure 8:17 - Open Water Station Type

Properties associated with the parameters for open water station type are defined in [Table 8:6](#),

Table 8-6 - Open Water Station Type - Properties

Parameter	Min	Max	Default	Decimals	Units	Required
Location	-1000	1000	empty	3	m or ft	Yes
Depth	0	100	empty	3	m or ft	Yes
Station Type			Open Water			Yes
Velocity Method						Yes
Correction Factor	-1	1	1	2		Yes
Comment	0	250	empty			No

The default velocity method selection is performed on two methods, the Six-Tenths and Two-Point methods. The default method selection is based on water depth with the following criteria,



- Six-Tenths method for water depths below user specified depth,
- Two-Point method for water depths above user specified depth.

The default velocity method is only recommendation and the user can change the method based on their requirements.

8.3.2.4 Ice

The **Ice** station type is used to create a station for under ice conditions, performing velocity measurements within a vertical at a station. Ice station type is used for discharge measurements where an ice layer covers the water surface. The Ice station type has specific parameters for incorporating parameters associated with the ice layer.

Ice station type parameters available on the **Add Station** screen consists of the following,

- a) Location,
- b) Depth,
- c) Station Type,
- d) Velocity Method,
- e) Ice Thickness,
- f) Water Surface to Bottom of Ice,
- g) Water Surface to Bottom of Slush
- h) Correction Factor,
- i) Comment.
- j) *To **select** a station type and or velocity method,*
 - i). Use the left or right arrow key to scroll through the station types and or velocity methods,
- k) *To **add** ice station and continue to velocity measurement,*
 - i). Press the Right Soft Key.
- l) *To **CANCEL** add ice station,*
 - i). Press the Left Soft Key.

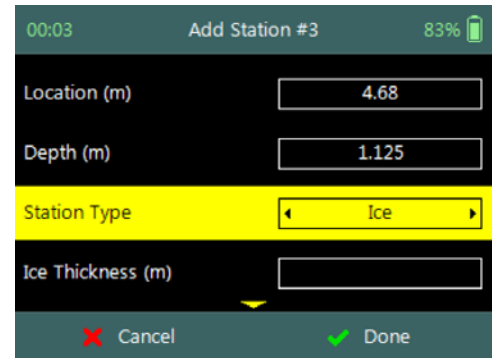

Figure 8:18 - Ice Station Type

Properties associated with the parameters for ice station type are defined in [Table 8:7](#),

Table 8-7 - Ice Station Type - Properties

Parameter	Min	Max	Default	Decimals	Units	Required
Location	-1000	1000	empty	3	m or ft	Yes
Depth	0	100	empty	3	m or ft	Yes
Station Type			Ice			Yes
Velocity Method						Yes
Ice Thickness	0	100	empty	3	m or ft	Yes
Water Surface to Bottom of Ice	0	100	empty	3	m or ft	Yes
Water Surface to Bottom of Slush	0	100	empty	3	m or ft	No
Correction Factor	-1	1	0.88	2		Yes
Comment	0	250	empty			No

8.3.3 Station Measurement (Wading Rod)

Station Measurement is performed at each station that was created from the subdivision of the measurements section into number of stations. The station measurement consists of collecting a number of different parameters and variables required for the Discharge Calculation Methods. Each station is unique with respect to the selection of the location, width between adjacent stations, velocity method, averaging interval used for velocity measurements and quality control parameters.

8.3.3.1 Station Parameters

The **Station Parameters** that need to be determined before a decision is made on what velocity method will be used are the station location with respect to the starting point on the tag line or measuring tape and the total water depth.

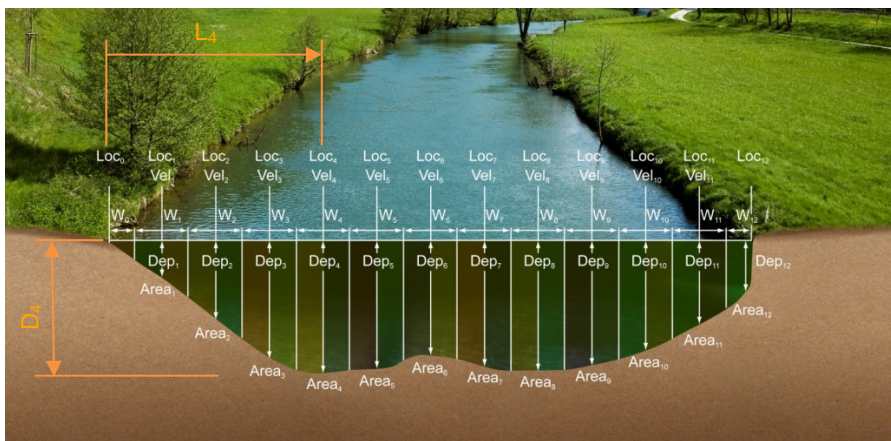

L_4 , is the distance from the start location on the tag line or measuring tape.

D_4 , is the water depth measured from the water surface to the channel bed.

Figure 8:19 - Station Parameters

The value of the start location on the tagline or measuring tape is not required to be zero (0.000m). The station location can also be entered in negative direction, with the start location at a larger value (e.g. 7.956m) and the end location at a smaller value (e.g. 0.532m). This feature assist when a measurement is performed from the left bank to the right bank and then back using the same tag line setup.



Start location of measurement at 0.532m

0.532 1.23 2.23 3.23 3.23 4.23 5.23 6.23 7.23 7.956

Start location of measurement at 7.956m

8.3.3.2 Point Velocity Measurement

The **Velocity Method** (see [Determining Mean Station Velocity](#)) selected for a station is based on the water depth, hydraulic conditions and the flow distribution within the measurement section.

- The number of point velocity measurements required within a vertical is dependent on the type of velocity method selected.

- The point velocity measurements are performed at a defined fractional depth based on the velocity method selected.

Step 1

Station parameters defined for **Velocity Measurement**, e.g., parameters of station 2m defined for velocity measurements are the following,

- Station location: 2m,
 - Water Depth: 1m,
 - Station Type: "Open Water",
 - Velocity Method: Two Point.
- To **add** open water station and continue to velocity measurement,
 - Press the Right Soft Key.
 - To **CANCEL** a new station,
 - Press the Left Soft Key.

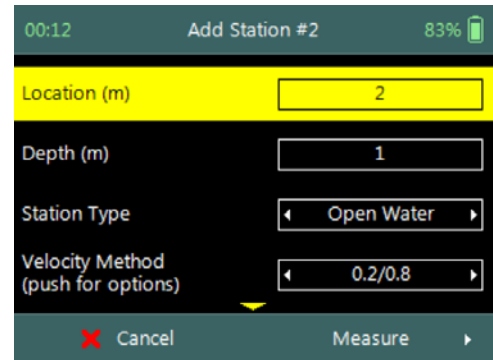

Figure 8:20 - Velocity Measurement

Step 2

Measurement screen display the point velocity measurements required at each fractional depth, e.g., the fractional depths for the two point method at station 2m with a water depth of 1m are the following,

- 0.2 x water depth, 0.2m
 - 0.8 x water depth, 0.8m
- To **select** a fractional measurement depth,
 - Use the up or down arrow key to scroll through the measurement options,
 - To **continue** to velocity measurement,
 - Press the enter key.
 - To **open** data collection menu,
 - Press the Right Soft Key.
 - To **REVERT** to add station screen,
 - Press the Left Soft Key.

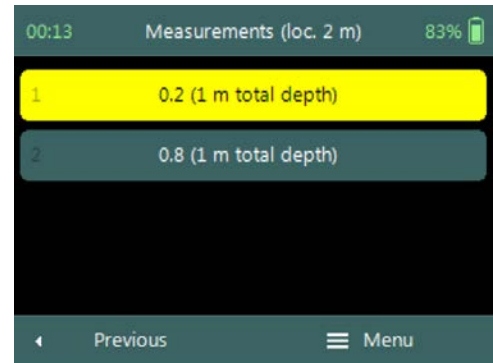
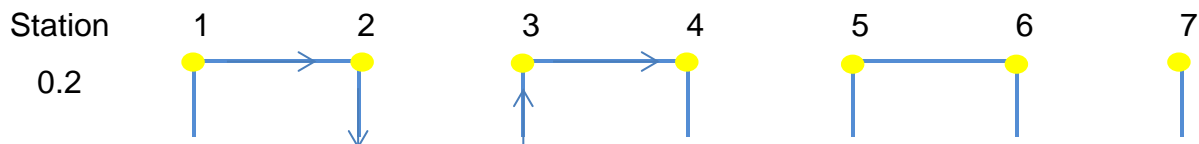

Figure 8:21 - Measurements



The order in how the point velocity measurements are performed at each fractional depth is not set and the user can perform the measurements in any order. The software highlights the same fractional depth that was measured at the previous station. This method reduces the number of key strokes and unnecessary adjustments on the wading rod.



0.8



Selecting the same fractional depth that was measured at the previous station improves the overall efficiency of the measurement. The example that is shown above shows a measurement where two-point method is performed at each station, keeping the order of measurements synced between stations improves the workflow.

Step 3

Setting Fractional Depth screen allow the setting and placement of the wading rod before velocity measurement is started,

- a) Wading rod setting,
- b) Beam Check,
- c) SNR,
- d) Tilt,
- e) Velocity angle.
- f) To **start** a velocity measurement,
 - i). Press the Right Soft Key.
- g) To **REVERT** to measurement screen,
 - i). Press the Left Soft Key.

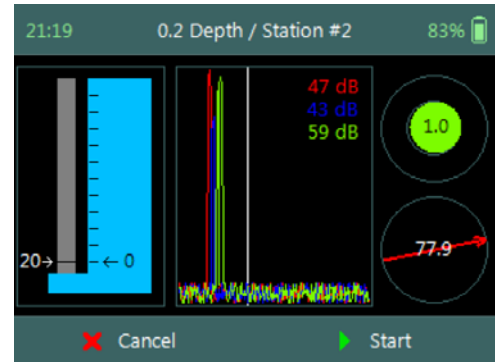

Figure 8:22 - Setting Fractional Depth

The key features of the **Setting Fractional Depth** are explained in [Figure 8:23](#).

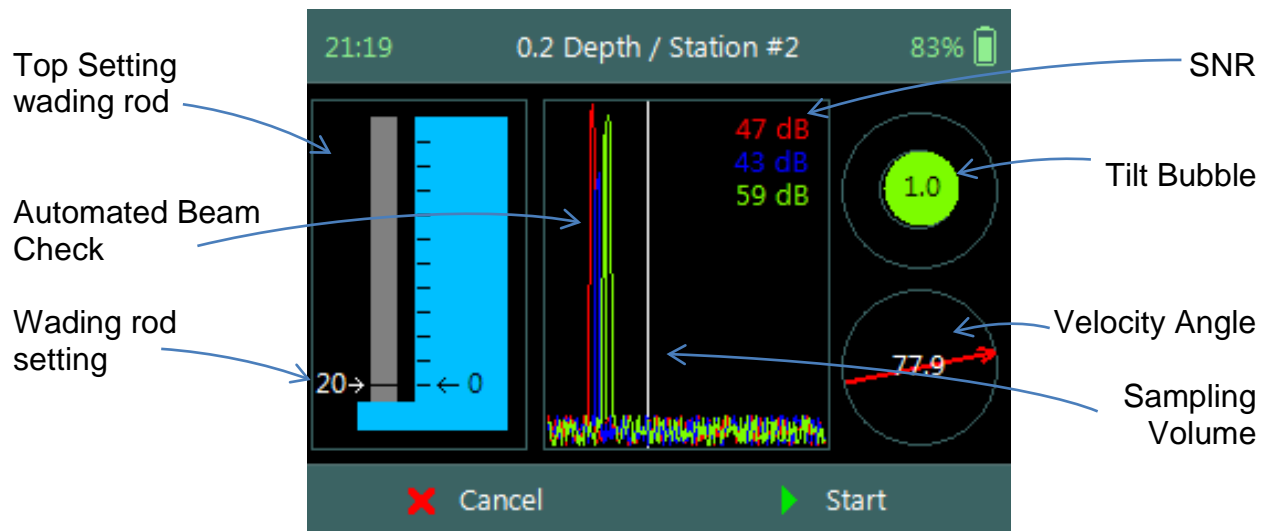

Figure 8:23 - Features of Setting Fractional Depth



The Sampling Volume of the instrument is defined by the white vertical line displayed on the Beam Profile plot in Figure 8:23. The location of the line is fixed and is based on the geometry of the beams. This is an excellent guide to indicate if the boundary is too close to the sampling volume.

Step 4

Fractional Depth Measurement screen displays graphical display of raw data of the following variables during a velocity measurement,

- a) Velocity,
- b) SNR,
- c) Temperature,
- d) Tilt,
- e) Vel. Angle,
- f) Battery.

Tilt and Velocity Angle indicators are situated on the right hand side of the screen.

- g) Tilt,
- h) Velocity Angle,
- i) Averaging Time left.
- j) *To select a variable graphical display,*
 - i). Use up or down scroll arrows keys to view a variable.
- k) *To stop sampling,*
 - i). Press the Right Soft Key.
- l) *To CANCEL velocity measurement,*
 - i). Press the Left Soft Key.

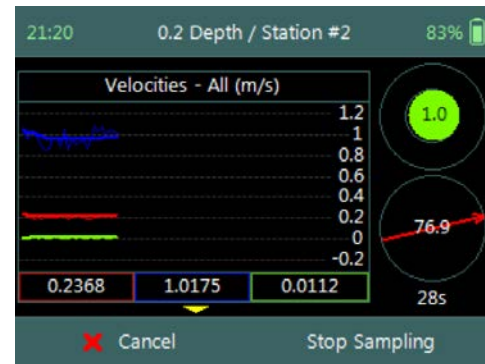

Figure 8:24 - Fractional Depth Measurement



The conventions and graphic display features used for displaying Velocity and SNR raw data are defined under [Raw Data Display](#).

8.3.3.3 Review Point Measurement

Review Point Measurement is a report supplied at the end of each point velocity measurement. The report consists of two components, tabular summary of numerical calculations performed on the raw data collected and graphical display of raw data.

Review Point Measurement screen consists of the following tabular summary and graphical displays,

Tabular Display

- a) Review Point Measurement, [Table 8:8](#)

Graphical Display of raw data are based on the following variables,

- b) Velocity,
- c) SNR,
- d) Temperature,
- e) Tilt,
- f) Velocity Angle,

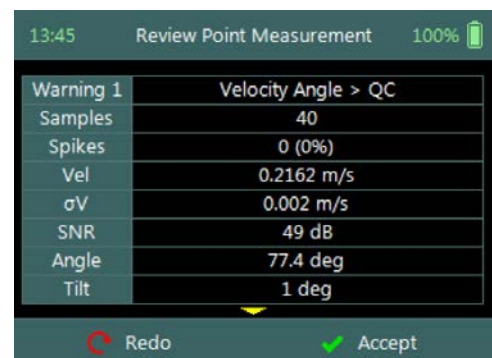

Figure 8:25 - Review Point Measurement

- g) Battery.
- h) *To select a variable,*
 - i). Use the up or down arrow key to view a variable.
- i) *To **accept** the velocity measurement,*
 - i). Press the Right Soft Key.
- j) *To **REDO** velocity measurement,*
 - i). Press the Left Soft Key.



The conventions and graphic display features used for displaying Velocity and SNR raw data are defined under [Raw Data Display](#).

Properties associated with the variable output from the numerical calculations performed on raw data collected is defined in [Table 8:8](#),

Table 8-8 - Review Point Measurement

Variable	Description	Units	Decimal
Samples	Total number of samples received.	number	n/a
Spikes	Number of spikes removed from mean velocity.	number	n/a
Vel	Mean X velocity component of all samples. Velocity is despiked and mounting correction applied (if applicable).	m/s or ft/s	4
σV	Standard error of X velocity component.	m/s or ft/s	4
SNR	Mean signal to noise ratio. Average of beam 1 and 2 SNR during point measurement.	dB	3
Angle	Flow angle relative to X direction. Angle between the mean X velocity component and mean Y velocity component.	Degree	2
Tilt	Mean wading rod angle during point velocity measurement.	Degree	2
Temp	Mean temperature during point measurement.	°C or °F	2
Bnd	Boundary QC value.	n/a	n/a

8.3.3.4 Review Station Measurement

Review Station measurement screen consist of tabular report and velocity distribution plot supplied at the completion of all point velocity measurements at a station. The variables supplied in the report are dependent on the features activated on the handheld, velocity method selected and the discharge calculation method. The velocity distribution plot gives graphical presentation of the point velocity measurements against theoretical 1/6th power law.

Review Station screen consists of tabular summary of all measurements performed at the station,

- a) Review Station, [Table 8:9](#).
- b) Velocity Distribution Plot,
 - i). Point velocity measurements at station against theoretical 1/6th power law.
 - ii). Graphical presentation of how velocity profile compare to theoretical 1/6th power law.
- c) To **close** the review station report,
 - i). Press the Right Soft Key.
 - ii). The software will navigate to the Data Collection Window.
- d) To **Add** station,
 - i). Press the Left Soft Key.

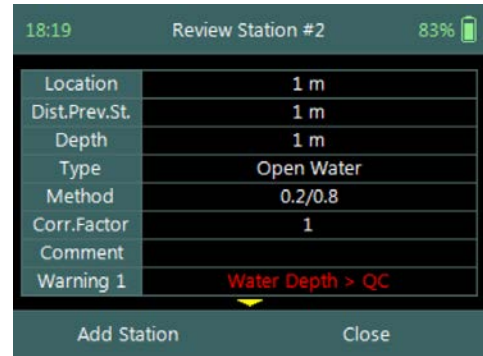

Figure 8:26 - Review Station

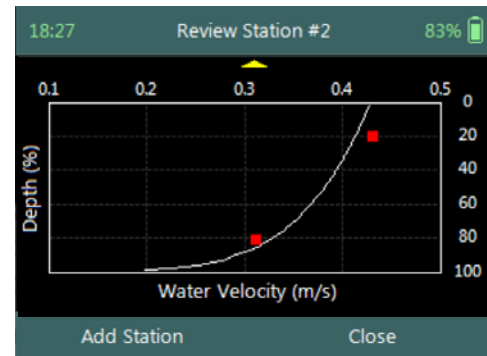

Figure 8:27 – Velocity Distribution

Properties associated with the variables and numerical calculations performed on the raw data collected at the station is defined in [Table 8:9](#),

Table 8-9 - Review Station

Variable	Description	Units	Decimal
Location	Station location measured from the start location on tag line or measuring tape.	m or ft	3
Dist. Prev. St.	Distance between current and previous station.	m or ft	3
Depth	Measured water depth or effective depth (for Ice method).	m or ft	3
Type	Station type (see Station Types).	n/a	n/a
Method	Discharge measurement method or velocity method (see Determining Mean Station Velocity).	n/a	n/a
Ice	Ice Thickness (only for Ice method).	m or ft	3
WS to BI	Water surface to bottom of ice (only for Ice method).	m or ft	3
WS to BS	Water surface to bottom of slush ice (only for Ice method).	m or ft	3
Corr. Factor	Mean station velocity (mean velocity in vertical) correction factor.		2
Comment	Text entered in comment fields during	n/a	n/a

Variable	Description	Units	Decimal
	measurement.		
%Q	Station discharge as a percent of the, <ul style="list-style-type: none"> weighted rated discharge, of rated discharge entries in supplement data or, measured discharge up to that station. 	%	2
StnQ	Station or panel discharge, per discharge method.	m ³ /s or ft ³ /s	4
TotalQ	Total discharge is the sum of all completed station or panel discharges, per discharge method.	m ³ /s or ft ³ /s	4
PanelVel	Panel velocity calculated based on discharge calculation method.	m/s or ft/s	4
MeanStVel	Mean Station Velocity or Mean Velocity in Vertical , X velocity component computed per velocity method. Velocity is despiked and mounting correction applied (if applicable).	m/s or ft/s	4
σV	Mean standard error of X velocity component of all point measurements.	m/s or ft/s	4
SNR	Mean signal to noise ratio of beams 1, 2 of all point measurements.	dB	3
Samples	Total number of samples received.	number	n/a
Spikes	Total number of spikes removed from mean velocity.	number	n/a
Angle	Mean flow angle relative to X direction. Average the velocity angle from each point measurement.	Degree	2
Tilt	Mean wading rod angle of all point velocity measurements.	Degree	2
Temperature	Mean Temperature of all point measurements.	°C or °F	2
Bnd	Lowest Boundary QC value.	n/a	n/a
GPS - Latitude	GPS derived Latitude	DDD° MM' SS.SS	
GPS - Longitude	GPS derived Longitude	DDD° MM' SS.SS	

8.3.4 Station Measurement ([Pressure Sensor](#))

Station Measurement is performed at each station that was created from the subdivision of the measurements section into number of stations. The station measurement consists of collecting a number of different parameters and variables required for the Discharge Calculation Methods. Each station is unique with respect to the selection of the location, width between adjacent stations, velocity method, averaging interval used for velocity measurements and quality control parameters.

8.3.4.1 Station Parameters

The **Station Parameters** that need to be determined before a decision is made on what velocity method will be used are the station location with respect to the starting point on the tag line or measuring tape and the total water depth.

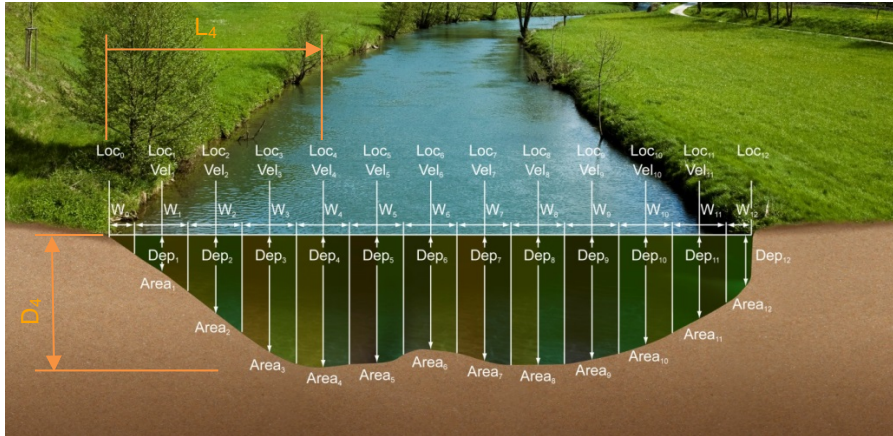

L₄, is the distance from the start location on the tag line or measuring tape.

D₄, is the water depth measured from the water surface to the channel bed.

Figure 8:28 - Station Parameters



The value of the start location on the tagline or measuring tape is not required to be zero (0.000m). The station location can also be entered in negative direction, with the start location at a larger value (e.g. 7.956m) and the end location at a smaller value (e.g. 0.532m). This feature assist when a measurement is performed from the left bank to the right bank and then back using the same tag line setup.

Start location of measurement at 0.532m

0.532 1.23 2.23 3.23 3.23

4.23 5.23 6.23 7.23 7.956

Start location of measurement at 7.956m

8.3.4.2 Point Velocity Measurement

The **Velocity Method** (see [Determining Mean Station Velocity](#)) selected for a station is based on the water depth, hydraulic conditions and the flow distribution within the measurement section.

- The number of point velocity measurements required within a vertical is dependent on the type of velocity method selected.
- The point velocity measurements are performed at a defined fractional depth based on the velocity method selected.

Step 1

Station parameters defined for **Velocity Measurement**, e.g., parameters of station 2m defined for velocity measurements are the following,

- a) Station location: 2m,
- b) Water Depth: 1m,
- c) Station Type: “Open Water”,
- d) Velocity Method: Two Point.
- e) *To **add** open water station and continue to velocity measurement,*
 - i). Press the Right Soft Key.
- f) *To **CANCEL** a new station,*
 - i). Press the Left Soft Key.

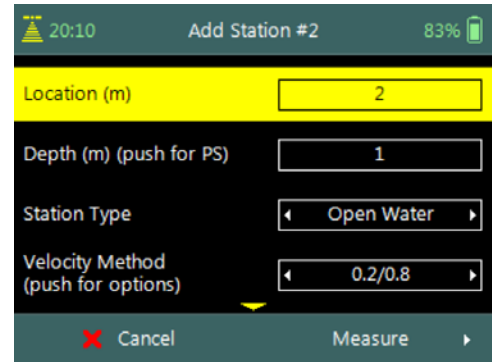

Figure 8:29 - Velocity Measurement



The water depth at each station can either be based on pressure sensor measurements or manually entered by the user. To perform pressure sensor measurement the Enter Key is pressed on the water depth parameter.

Step 2

Pressure Sensor (PS) Calibration allows the user to perform pressure sensor calibration. The screen is displayed before the first pressure sensor measurement is performed or when the **Air Pressure Cal. Period** expired.

- a) *To perform PS Calibration,*
 - i). Press the Right Soft Key.
- b) *To **CANCEL** PS Calibration,*
 - i). Press the Left Soft Key.

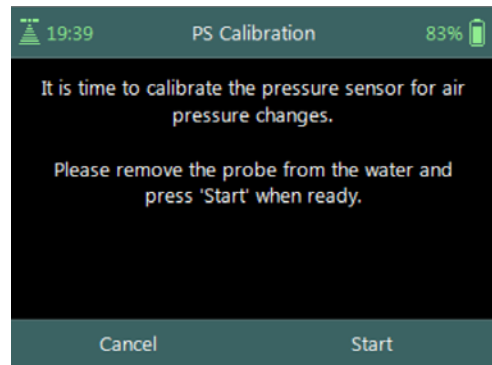

Figure 8:30 - PS Calibration

Step 3

Pressure Sensor (PS) Total Depth screen allows the user to perform depth measurement. The tilt sensor or bubble should be used to keep the instrument vertical.

- a) *To perform Depth Measurement,*
 - i). Press the Right Soft Key.
- b) *To **CANCEL** Depth Measurement,*
 - i). Press the Left Soft Key.

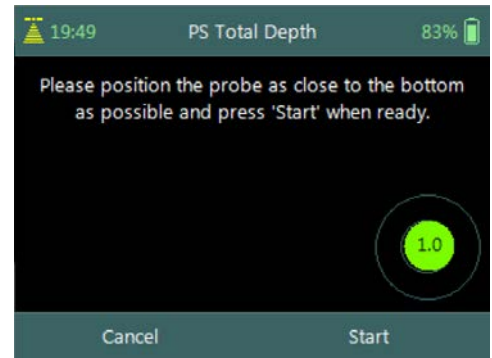

Figure 8:31 - PS Total Depth



The FlowTracker2 ADV Probe should be kept vertical during the pressure sensor measurements. Any angle on the probe will impact the pressure sensor measurements because the probe is off center of the wading rod.

Step 4

Measurement screen display the point velocity measurements required at each fractional depth, e.g., the fractional depths for the two point method at station 2m with a water depth of 1m are the following,

- 0.2 x water depth, 0.2m
 - 0.8 x water depth, 0.8m
- a) To **select** a fractional measurement depth,
 - i). Use the up or down arrow key to scroll through the measurement options,
 - b) To **continue** to velocity measurement,
 - i). Press the enter key.
 - c) To **open** data collection menu,
 - i). Press the Right Soft Key.
 - d) To **REVERT** to add station screen,
 - i). Press the Left Soft Key.

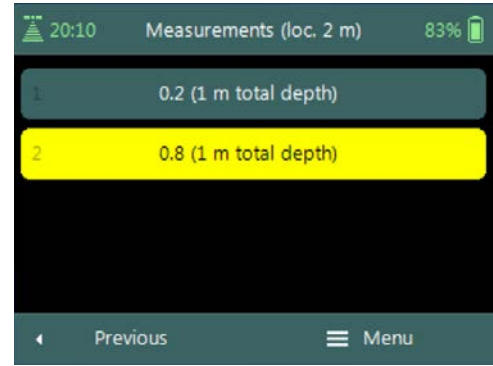
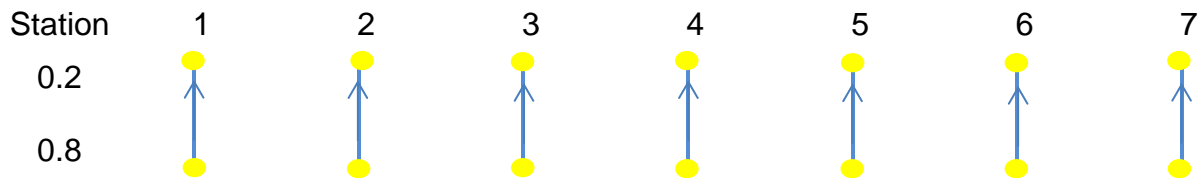

Figure 8:32 - Measurements



The order in how the point velocity measurements are performed at each fractional depth is not set and the user can perform the measurements in any order. The software will start at the bottom of each station for pressure sensor measurements.



Step 5

Setting Fractional Depth screen allow the setting and placement of the wading rod before velocity measurement is started,

- a) Pressure Sensor Depth Guide,
- b) Beam Check,
- c) SNR,
- d) Tilt,
- e) Velocity angle.
- f) To **start** a velocity measurement,
 - i). Press the Right Soft Key.
- g) To **REVERT** to measurement screen,
 - i). Press the Left Soft Key.

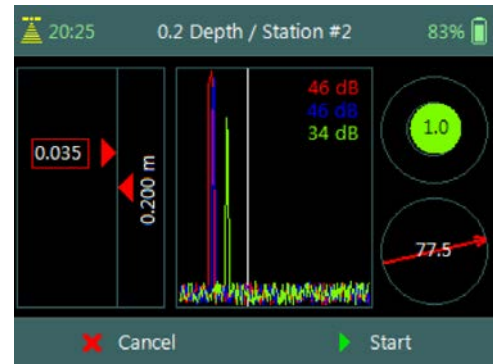

Figure 8:33 - Setting Fractional Depth

The key features of the **Setting Fractional Depth** are explained in [Figure 8:34](#).

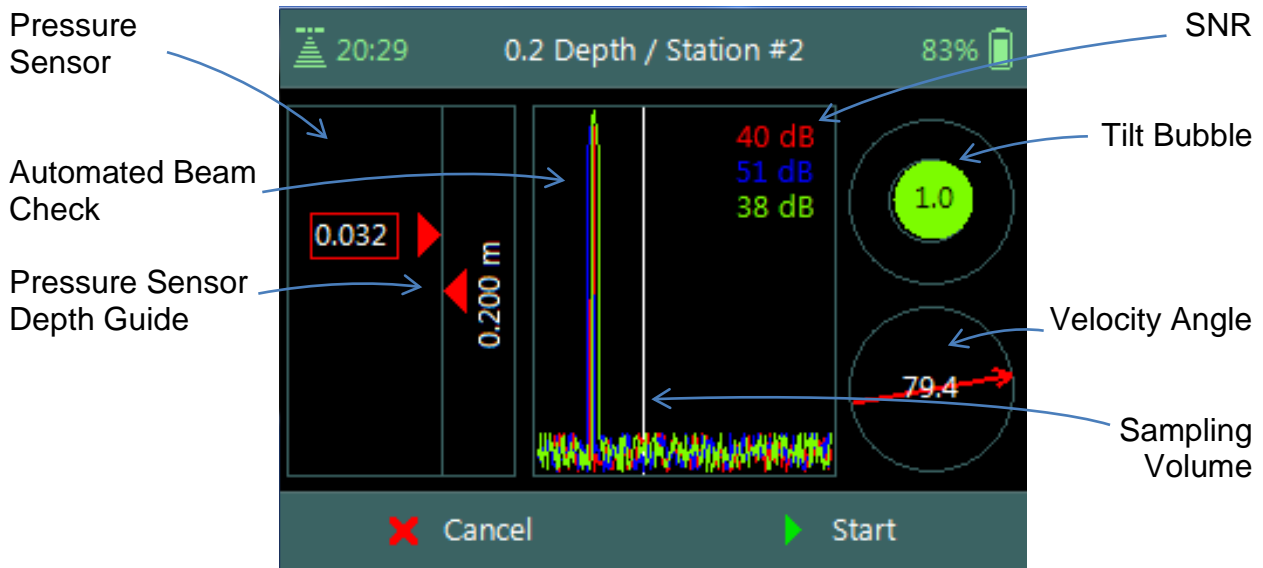

Figure 8:34 - Features of Setting Fractional Depth



The Sampling Volume of the instrument is defined by the white vertical line displayed on the Beam Profile plot in Figure 8:34. The location of the line is fixed and is based on the geometry of the beams. This is an excellent guide to indicate if the boundary is too close to the sampling volume.

Step 6

Fractional Depth Measurement screen displays graphical display of raw data of the following variables during a velocity measurement,

- a) Velocity,
- b) SNR,
- c) Temperature,
- d) Tilt,
- e) Vel. Angle,
- f) Probe Depth,
- g) Battery,
- h) Pressure.

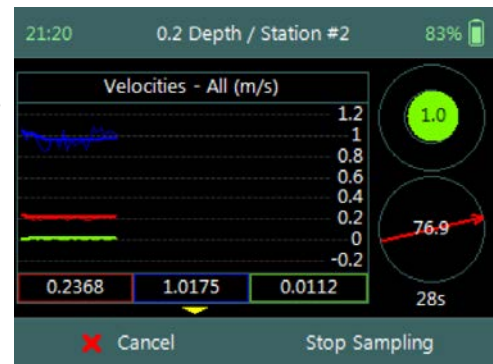

Figure 8:35 - Fractional Depth Measurement

Tilt and Velocity Angle indicators are situated on the right hand side of the screen.

- i) Tilt,
- j) Velocity Angle,
- k) Averaging Time left.
- l) *To select a variable graphical display,*
 - i). Use up or down scroll arrows keys to view a variable.
- m) *To stop sampling,*
 - i). Press the Right Soft Key.
- n) *To CANCEL velocity measurement,*
 - i). Press the Left Soft Key.



The conventions and graphic display features used for displaying Velocity and SNR raw data are defined under [Raw Data Display](#).

8.3.4.3 Review Point Measurement

Review Point Measurement is a report supplied at the end of each point velocity measurement. The report consists of two components, tabular summary of numerical calculations performed on the raw data collected and graphical display of raw data.

Review Point Measurement screen consists of the following tabular summary and graphical displays,

Tabular Display

- a) Review Point Measurement, [Table 8:10](#)

Graphical Display of raw data are based on the following variables,

- b) Velocity,
- c) SNR,
- d) Temperature,
- e) Tilt,
- f) Velocity Angle,
- g) Probe Depth,
- h) Battery,
- i) Pressure.
- j) *To select a variable,*
 - i). Use the up or down arrow key to view a variable.
- k) *To accept the velocity measurement,*
 - ii). Press the Right Soft Key.
- l) *To REDO velocity measurement,*
 - ii). Press the Left Soft Key.

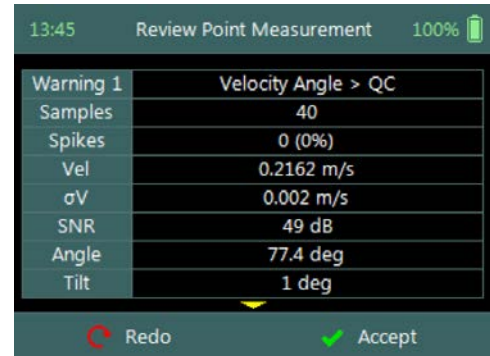

Figure 8:36 - Review Point Measurement



The conventions and graphic display features used for displaying Velocity and SNR raw data are defined under [Raw Data Display](#).

Properties associated with the variable output from the numerical calculations performed on raw data collected is defined in [Table 8:10](#),

Table 8-10 - Review Point Measurement

Variable	Description	Units	Decimal
Samples	Total number of samples received.	number	n/a
Spikes	Number of spikes removed from mean velocity.	number	n/a
Vel	Mean X velocity component of all samples. Velocity is despiked and mounting correction	m/s or ft/s	4

Variable	Description	Units	Decimal
	applied (if applicable).		
σV	Standard error of X velocity component.	m/s or ft/s	4
SNR	Mean signal to noise ratio. Average of beam 1 and 2 SNR during point measurement.	dB	3
Angle	Flow angle relative to X direction. Angle between the mean X velocity component and mean Y velocity component.	Degree	2
Bnd	Boundary QC value.	n/a	n/a
Tilt	Mean wading rod angle during point velocity measurement.	Degree	2
Temp	Mean temperature during point measurement.	°C or °F	2
Depth	Mean water depth from water surface during point measurement	m or ft	3
Pressure	Mean water pressure during point measurement	dbar	3

8.3.4.4 Review Station Measurement

Review Station measurement screen consists of tabular report and velocity distribution plot supplied at the completion of all point velocity measurements at a station. The variables supplied in the report are dependent on the features activated on the handheld, velocity method selected and the discharge calculation method. The velocity distribution plot gives graphical presentation of the point velocity measurements against theoretical 1/6th power law.

Review Station screen consists of tabular summary of all measurements performed at the station,

- a) Review Station, [Table 8:11](#).
- b) Velocity Distribution Plot,
 - i). Point velocity measurements at station against theoretical 1/6th power law.
 - ii). Graphical presentation of how velocity profile compare to theoretical 1/6th power law.

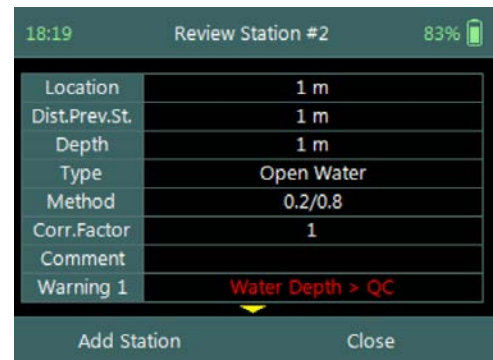

Figure 8:37 - Review Station

- c) To **close** the review station report,
 - i). Press the Right Soft Key.
 - ii). The software will navigate to the Data Collection Window.
- d) To **Add** station,
 - i). Press the Left Soft Key.

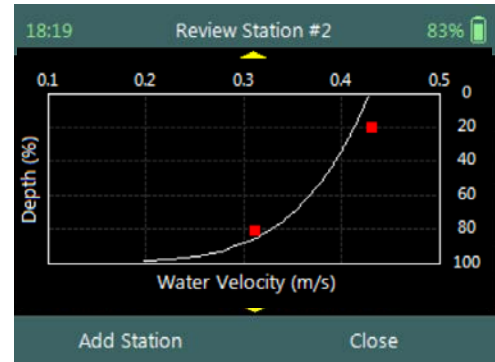

Figure 8:38 – Velocity Distribution

Properties associated with the variables and numerical calculations performed on the raw data collected at the station is defined in [Table 8:11](#),

Table 8-11 - Review Station

Variable	Description	Units	Decimal
Location	Station location measured from the start location on tag line or measuring tape.	m or ft	3
Dist. Prev. St.	Distance between current and previous station.	m or ft	3
Depth	Measured water depth or effective depth (for Ice method).	m or ft	3
Type	Station type (see Station Types).	n/a	n/a
Method	Discharge measurement method or velocity method (see Determining Mean Station Velocity).	n/a	n/a
Ice	Ice Thickness (only for Ice method).	m or ft	3
WS to BI	Water surface to bottom of ice (only for Ice method).	m or ft	3
WS to BS	Water surface to bottom of slush ice (only for Ice method).	m or ft	3
Corr. Factor	Mean station velocity (mean velocity in vertical) correction factor.		2
Comment	Text entered in comment fields during measurement.	n/a	n/a
%Q	Station discharge as a percent of the, <ul style="list-style-type: none"> • weighted rated discharge, of rated discharge entries in supplement data or, • measured discharge up to that station. 	%	2
StnQ	Station or panel discharge, per discharge method.	m ³ /s or ft ³ /s	4
TotalQ	Total discharge is the sum of all completed station or panel discharges, per discharge method.	m ³ /s or ft ³ /s	4
MeanStVel	Mean Station Velocity or Mean Velocity in	m/s or ft/s	4

Variable	Description	Units	Decimal
	Vertical , X velocity component computed per velocity method. Velocity is despiked and mounting correction applied (if applicable).		
σV	Mean standard error of X velocity component of all point measurements.	m/s or ft/s	4
SNR	Mean signal to noise ratio of beams 1, 2 of all point measurements.	dB	3
Samples	Total number of samples received.	number	n/a
Spikes	Total number of spikes removed from mean velocity.	number	n/a
Angle	Mean flow angle relative to X direction. Average the velocity angle from each point measurement.	Degree	2
Tilt	Mean wading rod angle of all point velocity measurements.	Degree	2
Temperature	Mean Temperature of all point measurements.	°C or °F	2
Bnd	Lowest Boundary QC value.	n/a	n/a
GPS - Latitude	GPS derived Latitude	DDD° MM' SS.SS	
GPS - Longitude	GPS derived Longitude	DDD° MM' SS.SS	

8.3.5 Data Collection Menu

Data Collection Menu allows the user to adjust measurement settings, enter staff gauge readings and rated discharge data and view measurement summary. The data collection menu can be accessed in between point velocity measurements or stations and this ensures that the instrument is configured for current flow conditions present.

Data Collection Menu screen consists of the following functions that are available in Discharge Mode,

- a) Complete Measurement,
- b) Settings,
- c) Supplemental Data,
- d) Discharge Summary,
- e) Stations Summary,
- f) Automated Beam Check,
- g) PS Calibration,
- h) Discard Measurement,
- i) Go to Home Screen.
- j) *To select a function,*
 - i). Use the up or down arrow key to scroll through the functions,

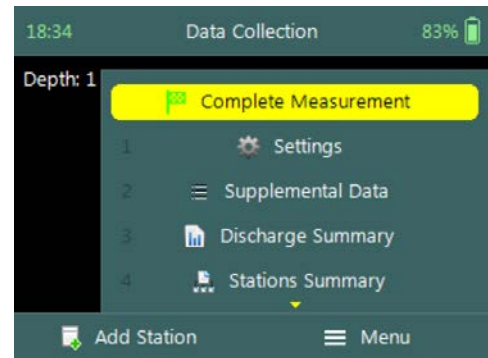

Figure 8:39 - Data Collection Menu

- k) To **open** or **CLOSE** the data collection menu,
 - i). Press the Right Soft Key.

8.3.5.1 Settings

The **Settings** menu option gives the user access to the initial measurement settings that were configured during the configuration of the discharge template.

Settings screen consists of the following functions for configuring measurement settings,

- a) File Properties,
 - b) Data Collection Settings,
 - c) Quality Control Settings
 - d) Discharge Settings.
- e) To **select** a function,
- i). Use the up or down arrow key to scroll through the functions,
- f) To **CLOSE** the settings menu,
- i). Press the Left Soft Key.

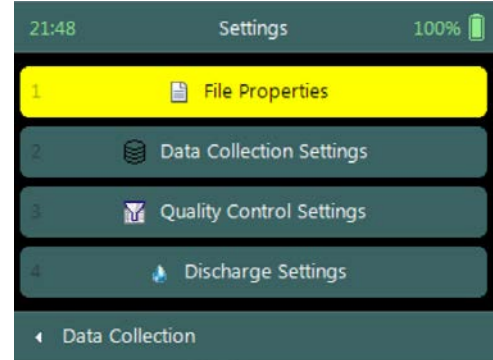

Figure 8:40 - Settings Menu



The measurement settings functions supplied in the Settings option in data collection menu are defined under [Template Functions](#).

8.3.5.2 Supplemental Data

Supplemental Data function enables the user to enter staff gauge readings, rated discharge and other variables during the discharge measurement. The staff gauge readings and rated discharge are used to compute [Weighted Gauge Height](#). The rated discharge is also used to determine percentage discharge at each station or panel during a discharge measurement.

Supplemental Data screen display the supplemental data entered and is sorted by the time the staff gauge readings were taken. The supplemental data can be entered during any stage of the measurement before the “Complete Measurement” function is selected.

- a) To **add** supplemental data,
 - i). Press the Right Soft Key,
- b) To **CLOSE** supplemental data,
 - i). Press the Left Soft Key.

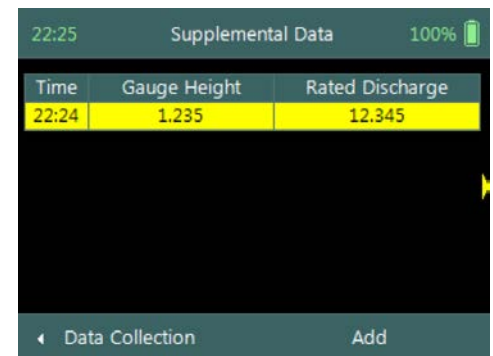

Figure 8:41 - Supplemental Data



The time and date entered for each supplemental dataset should be the time when the staff gauge reading was taken and not the time when the data was entered.

Add Gauge Height screen consists of the following variables required in supplemental data,

- a) Date,
- b) Time,
- c) Gauge Height,
- d) Rated Discharge,
- e) Temperature,
- f) Salinity,
- g) Comment.

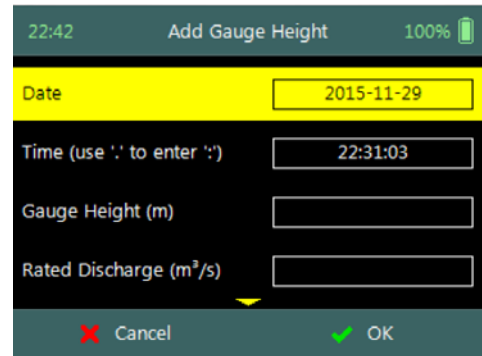

Figure 8:42 - Add Gauge Height

- c) To **accept** supplemental data,
 - i). Press the Right Soft Key,
- d) To **CANCEL** supplemental data entry,
 - i). Press the Left Soft Key.



The staff gauge readings, rated discharge and associated data captured in Supplemental Data should be accurate and complete. It is important that these variables are entered correctly for accurate calculation of weighted gauge height and or percentage discharge.

8.3.5.3 Discharge Summary

Discharge Summary from the data collection menu displays the discharge and other variables measured from all completed stations. Discharge summary requires at least one station with velocity measurements to populate the main variables in the table.

Discharge Summary screen consists of tabular summary of discharge and other variables measured up to specific point,

- a) Discharge Summary, [Table 8:12](#).
- b) To **close** the discharge summary report,
 - i). Press the Left Soft Key.
 - ii). The software will navigate to the Data Collection Window.

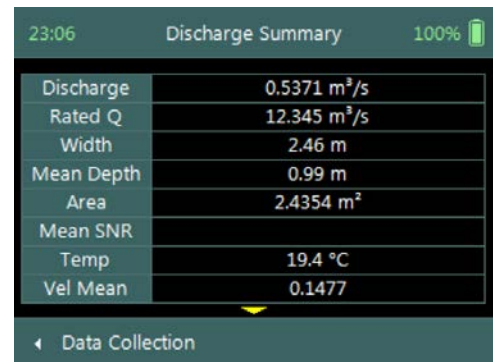

Figure 8:43 - Discharge Summary

Properties associated with the variables and numerical calculations performed on the raw data collected is defined in [Table 8:12](#),

Table 8-12 - Discharge Summary

Variable	Description	Units	Decimal
Discharge	Total discharge is the sum of all station or panel discharges, per discharge method.	m ³ /s or ft ³ /s	4
RatedQ	Rated discharge entered in supplemental data.	m ³ /s or ft ³ /s	4
Width	Total width calculated from all stations and or	m or ft	3

Variable	Description	Units	Decimal
	panels, per discharge method.		
Mean Depth	Average depth calculated from the total area and width.	m or ft	3
Area	Total area calculated from all stations or panels, per discharge method.	m ² or ft ²	4
Mean SNR	Average SNR of all completed stations. Require at least 3 stations.	dB	n/a
Temp	Average temperature of all completed stations.	°C or °F	2
Vel Mean	Average station velocity, X velocity component	m/s or ft/s	4
Vel Min	Minimum station velocity, X velocity component	m/s or ft/s	4
Vel Max	Maximum station velocity, X velocity component	m/s or ft/s	4
Height, Start	Start staff gauge reading.	m or ft	3
Height, End	End staff gauge reading.	m or ft	3
Uncertainty	Uncertainty in discharge measurement.	%	2
Largest Uncertainty	Largest uncertainty in the discharge uncertainty calculation.	%	2
GPS - Latitude	GPS derived Latitude	DDD° MM' SS.SS	
GPS - Longitude	GPS derived Longitude	DDD° MM' SS.SS	

8.3.5.4 Station Summary

The **Station Summary** from the data collection menu displays the completed stations in table format. The station summary is a good reference when evaluating measurements performed at a station against adjacent stations.

Station Summary screen consists of tabular view of all completed stations,

- a) Station Summary, [Table 8:13](#).
- b) *To close the discharge summary report,*
 - i). Press the Left Soft Key.
 - ii). The software will navigate to the Data Collection Window.



Figure 8:44 - Station Summary

Properties associated with the variables and numerical calculations performed on the raw data collected is defined in [Table 8:13](#),

Table 8-13 - Station Summary

Variable	Description	Units	Decimal
----------	-------------	-------	---------

Variable	Description	Units	Decimal
Loc	Station location measured from the start location on tag line or measuring tape.	m or ft	3
Depth	Measured water depth or effective depth (for Ice method).	m or ft	3
Type	Station type (see Station Types).	n/a	n/a
Method	Discharge measurement method or velocity method (see Determining Mean Station Velocity).	n/a	n/a
Corr. Factor	Mean station velocity (mean velocity in vertical) correction factor.	None	3
Panel Vel	Panel velocity calculated based on discharge calculation method.	m/s or ft/s	4
MeanStVel	Mean Station Velocity or Mean Velocity in Vertical , X velocity component computed per velocity method. Velocity is despiked and mounting correction applied (if applicable).	m/s or ft/s	4
Width	Panel width, per discharge method.	m or ft	3
Area	Panel area, per discharge method.	m ² /s or ft ² /s	4
Flow	Panel discharge, per discharge method.	m ³ /s or ft ³ /s	4
%Q	Station discharge as a percent of the, <ul style="list-style-type: none"> weighted rated discharge, of rated discharge entries in supplement data or, measured discharge up to that station. 	%	2
Angle	Mean flow angle relative to X direction. Average the velocity angle from each point measurement	Degree	2
Tilt	Mean wading rod angle of all point velocity measurements.	Degree	2
Temp	Mean Temperature of all point measurements.	°C or °F	2
GPS - Latitude	GPS derived Latitude	DDD° MM' SS.SS	
GPS - Longitude	GPS derived Longitude	DDD° MM' SS.SS	

8.3.5.5 Automated Beam Check

Automated Beam Check function in the data collection menu allows the user to perform beam check during any stage of the discharge measurement. The Automated Beam Check function operations, conventions and graphic display features are defined under [Automated Beam Check](#).



Automated Beam Checks performed during the discharge measurement are stored in FlowTracker2 file (.ft) that was created for the measurement site.

8.3.5.6 PS Calibration (Pressure Sensor)

The **PS Calibration** function in the data collection menu allows the user to perform Pressure Sensor Calibration during any stage between point velocity measurements.



Frequent calibration of pressure sensor for atmospheric or air pressure changes during the measurement will improve the accuracy of pressure measurements. The variation in atmospheric or air pressure will impact the accuracy of pressure measurements.

Step 1

PS Calibration screen allows the user to perform pressure sensor calibration. The user is required to remove the probe from the water.

- a) To perform PS Calibration,
 - i). Press the Right Soft Key.
- b) To **CANCEL** PS Calibration,
 - i). Press the Left Soft Key.

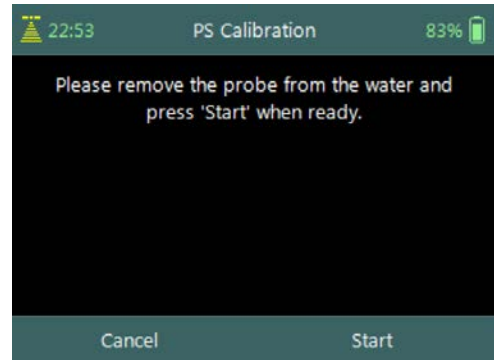

Figure 8:45 – PS calibration

Step2

PS Calibration screen with **Quality Control** warning messages based on quality control checks performed on measurement data.

- a) To **accept** quality control warning messages,
 - i). Press the Right Soft Key.
- b) To **REDO** PS Calibration,
 - i). Press the Left Soft Key.

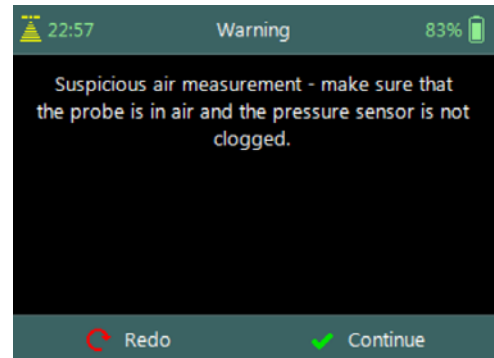

Figure 8:46 - Warning Messages

8.3.5.7 Complete Measurement

The **Complete Measurement** function closes the measurement file and the user will not be able to add additional stations and or make any changes to the data captured. The complete measurement function is a three-step process, firstly to determine if the user is satisfied with the discharge measurement, secondly to perform quality control checks against all measurement data and lastly to review discharge summary.



The Complete Measurement process allows the user to review the measurement data before the complete function is selected at Summary screen. The user will not be able to make any to changes to the measurement file from the handheld when this function is selected.

Step 1

Confirmation screen of **Complete Measurement** function confirms if the user wants to close the measurement file. User will not be able to add stations or make any changes to the data

- c) To **confirm** complete measurement operation,
 - ii). Press the Right Soft Key.
- d) To **CANCEL** complete measurement operation,
 - ii). Press the Left Soft Key.

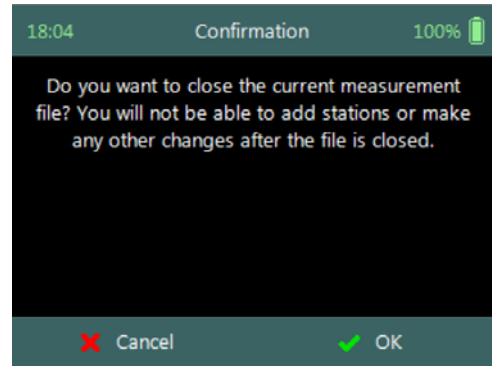

Figure 8:47 - Confirmation Complete Measurement

Step2

Confirmation screen with **Quality Control** warning messages based on quality control checks performed on measurement data.

- c) To **accept** quality control warning messages,
 - ii). Press the Right Soft Key.
- d) To **CANCEL** complete measurement operation,
 - ii). Press the Left Soft Key.

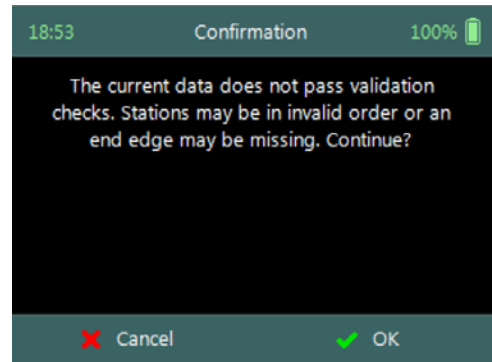

Figure 8:48 - Confirmation Quality Control Messages

Step3

Summary screen displays the discharge summary report before the measurement file is closed for further data entry and editing.

- a) To **confirm** complete measurement operation,
 - i). Press the Right Soft Key.
 - ii). The software will navigate to the Main Menu.
- b) To **CANCEL** complete measurement operation,
 - i). Press the Left Soft Key.



Figure 8:49 - Summary Discharge Measurement

8.3.5.8 Discard Measurement

The **Discard Measurement** function will discard all configuration settings, stations and other data related with the measurement.



Discarding a measurement will result in deleting all data of the measurement site that is related to the specific measurement file.

Warning screen of **Discard Measurement** function displays the warnings associated with discarding measurement file.

- a) To **DISCARD** measurement,
 - i). Press the Right Soft Key.
 - ii). The software will navigate to the Main Menu.
- b) To **CANCEL** discard measurement operation,
 - i). Press the Left Soft Key.

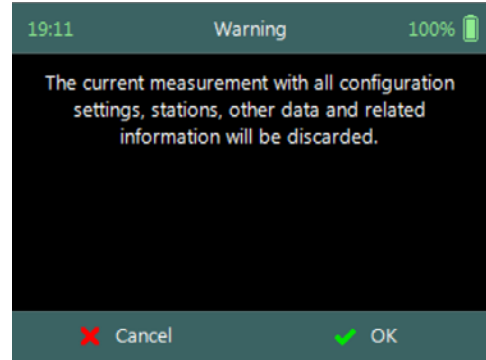

Figure 8:50 - Warning Discard Measurement

8.3.5.9 Go to Home Screen

The **Go to Home Screen** function will navigate the software to the main menu and the user will have the ability to access software functions that are not related to Discharge Mode function.



The discharge measurement can be accessed during any stage by selecting the “Data Collection” function with the Right Soft Key. The software will continue with the measurement at the exact stage when the user navigated away from the discharge mode.

8.4. Measurement Summary

Measurement Summary is supplied when the Complete Measurement function is selected and displays all the measurement results. The Measurement Summary is the last verification of the measurement results before the measurement file is closed for any further measurements or changes.

Measurement Summary screen consists of tabular summary of discharge measurement results,

- a) Discharge Summary, [Table 8:14](#).
- b) To **CANCEL** the discharge summary report,
 - i). Press the Left Soft Key.
 - ii). The software will navigate to the Data Collection Window.
- c) To **COMPLETE** the discharge measurement,
 - i). Press the Right Soft Key.
 - ii). The software will close the measurement file and navigate to the main menu.



Figure 8:51 - Measurement Summary

Properties associated with the variables and numerical calculations performed on the raw data collected is defined in [Table 8:14](#),

Table 8-14 - Measurement Summary

Variable	Description	Units	Decimal
File Type	File type based on discharge or general mode	n/a	n/a
Site Name	Site name populated by user	n/a	n/a
Site Number	Site number populated by user	n/a	n/a
Operator	Operator name populated by user	n/a	n/a
Started	Start date and time when measurement was created	yyyy-mm-dd hh:mm	
Completed	End data and time when measurement was completed	yyyy-mm-dd hh:mm	
Stations	Total number of stations within the measurement	n/a	n/a
Comment	General comment captured against measurement	n/a	n/a
Discharge	Total discharge calculated	m ³ /s or ft ³ /s	4
Rated Q	Rated discharge entered by user	m ³ /s or ft ³ /s	4
Width	Total width of the measurement section	m or ft	3
Mean Depth	The mean depth of the measurement section calculated from the total area and width.	m or ft	3
Area	Total area of the measurement section	m ² or ft ²	4
Mean SNR	Average signal to noise ration	dB	
Temp	Average temperature measured	°C or °F	
Vel Mean	Average station velocity, X velocity component	m/s or ft/s	4
Vel Min	Minimum station velocity, X velocity component	m/s or ft/s	4
Vel Max	Maximum station velocity, X velocity component	m/s or ft/s	4
Height, Start	First staff gauge reading	m or ft	3
Height, End	Last staff gauge reading	m or ft	3
Uncertainty	Uncertainty in discharge measurement	%	2
Largest Uncertainty	Largest uncertainty in the discharge uncertainty calculation	%	2
GPS - Latitude	GPS derived Latitude	DDD° MM' SS.SS	
GPS - Longitude	GPS derived Longitude	DDD° MM' SS.SS	

Section 9. General Measurement

General Measurement is the measurement technique involved in collecting velocity data based on the General Mode (see [Data Collection Modes](#)). The data collection framework designed for collecting velocity data is detailed in [Software Flow Diagram](#). Velocity data collection process consists of the following main components, with discussions of each component.

- Create Measurement,
- Automated Beam Check,
- Data Collection,
- Discharge Summary.

9.1. Create Measurement

Creating a new measurement consists of a number of steps before the data collection can be performed. The first step involved is to either select an existing [Configuration Template](#) or create a new template with user defined configuration parameters. The template then needs to be associated with a measurement file that is created by the user. When the measurement file is created, the software is ready for data collection.

9.1.1 Measurement

The **Measurement** function enables the user to create a new measurement in either Discharge or General mode. The General mode used for the collection of velocity data during field measurements will be focused on in this section.

- a) The Measurement function can be accessed from the Main Menu on the bottom banner,
- b) *To select the Measurement function,*
 - i). Press the Right Soft Key.
- c) *The software will navigate to the New File Type or Mode screen.*

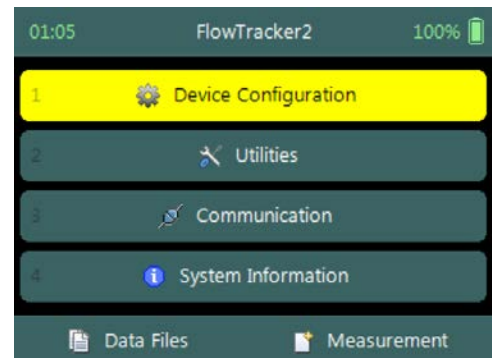

Figure 9:1 - Main Menu

9.1.2 New File Type

The **New File Type** function enables the user to determine if the new measurement file should be based on either Discharge or General mode.

The **New File Type** screen consists of the following options,

- a) Discharge,
- b) General,
- c) *To select discharge mode,*
 - i). Use up or down scroll arrows keys to select Discharge and press enter key.
- d) *The software will navigate to the New File Template screen.*
- e) *To navigate to Home menu,*
 - i). Press the Left Soft Key.

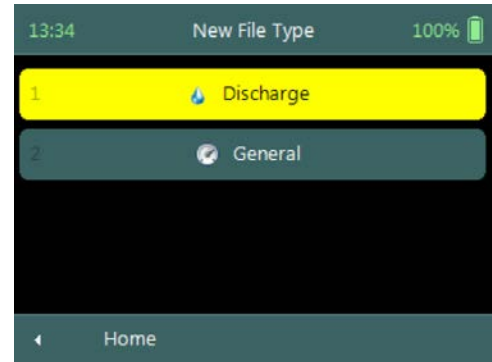

Figure 9:2 - New File Type

9.1.3 New File Template

New File Template function enables the user to create a new configuration template based on SonTek default settings or select an existing [Configuration Template](#) created by the user. The configuration template is based on user defined parameters that are dependent on measurement site details, flow conditions and organizational requirements. The configuration template selected will be assigned to the measurement file and the parameters defined in the template will be applied during the Velocity measurement.

The **New File Template** screen consists of the following options,

- a) **(default)**, the template will be based on SonTek default settings.
- b) [Existing Templates](#), created under “Device Configuration”. A list of available templates created by the user will be displayed under the “(default)” option.
- c) *To select a template,*
 - i). Use up or down scroll arrows keys to select template and press enter key.
- d) *The software will navigate to the New Data File screen.*
- e) *To navigate to File Type menu,*
 - i). Press the Left Soft Key.

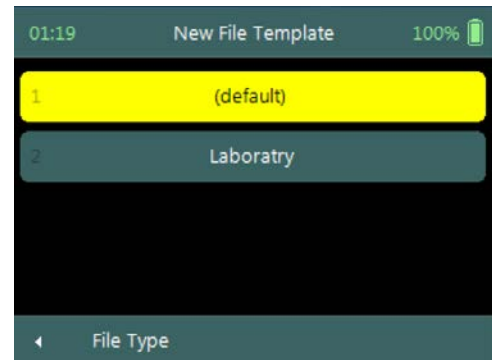

Figure 9:3 - New File Template

9.1.4 New Data File

New Data File function enables the user to populate the measurement site and operator details. The information entered for each parameter should be accurate as this

information is recorded in each measurement file and used in both the [File Naming](#) and [Folder Naming](#) conventions.

- Existing templates created under “Device Configuration”, parameters will be prepopulated from [File Properties](#) information that was captured,
- Templates based on SonTek default configuration will have no information populated and the user will need to enter the required details for each parameter.



It is not good data management practice for both measurement site references to be empty or with abbreviate terms. It is recommended that the user makes use of accurate site descriptions.

The **New Data File** screen consists of the following parameters,

- Site Number,
 - Site Name,
 - Operator,
 - Comment.
- To **select** a parameter,*
 - Use up or down scroll arrows keys to select a parameter.
 - To **accept** the new data file configuration,*
 - Press the Right Soft Key,
 - The software will navigate to Automated Beam Check screen.
 - To **CANCEL** new data file configuration,*
 - Press the Left Soft Key,
 - The software will return to New File Template.

Figure 9:4 - New Data File

9.2. Automated Beam Check



Duplicate of [6.4 Automated Beam Check](#)

The **Automated Beam Check** function allows the user to perform a Beam Check in the region of the measurement location before data collection starts. The automated beam check performs a number of quality control checks on the data collected to determine if the flow conditions are suitable for velocity measurements. The data displayed graphically during the Automated BeamCheck is a time series of the Quality Control parameters.



The **Automated BeamCheck** is an automated version of Beam Check function described in [6.3 Beam Check](#). In the Original FlowTracker, the Automated Beam Check was known as “Auto QC Test”.



Automated Beam Check can be performed during any stage of the data collection process. The Automated Beam Check functions are available before data collection start and during velocity measurement from the “Data Collection Menu” (see [Data Collection Screen](#)).

9.2.1 Start Automated Beam Check

The FlowTracker2 probe should be placed in the region of the measurement location in moving water such that the probe is submerged and well away from any underwater obstacles. The FlowTracker2 collects data for about 20 seconds.

The **Automated Beam check** screen shows the steps involved in performing an automated beam check.

- a) To **start** the automated beam check,
 - i). Press the Right Soft Key.
- b) To **CANCEL** automated beam check,
 - i). Press the Left Soft Key,
 - ii). The software will navigate to Data Collection window.
- c) To **accept** Automated Beam Check,
 - i). Press the Right Soft Key,
 - ii). The software will navigate to the Data Collection window.

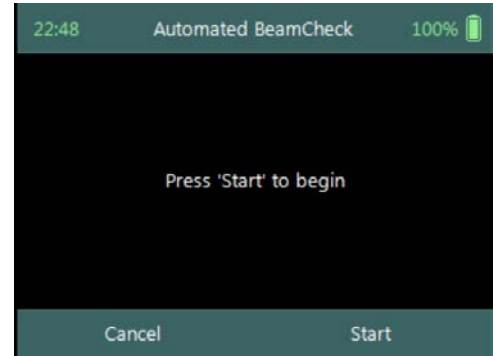

Figure 9:5 - Automated Beam Check

9.2.2 Evaluate Beam Check Results

The automated beam check quality control criteria used in the evaluation of the beam check data are listed in [Table 9:1](#),

Table 9-1 - Automated Beam Check Quality Control Criteria

Quality Control	Criteria	QC Warning	Graphic Display
Noise Level	<ul style="list-style-type: none"> • Measured electronics noise level is compared to reference data. Any significant deviation causes a warning, • A large change in noise level may indicate damage to the probe. • Noise level supplied in Automated BeamCheck is given in Counts. Multiply with 0.43 to convert to dB. 	Noise Level > QC	

Quality Control	Criteria	QC Warning	Graphic Display
SNR	<ul style="list-style-type: none"> The SNR is checked as sufficient for reliable data collection, Each beam SNR is compared to be sure all beams perform equally, A warning is issued for low SNR < 4 dB, A warning is issued for 4 dB < SNR < 7dB, Beam SNR values differ. 	SNR	
Peak Level	<ul style="list-style-type: none"> The shape of the sampling volume curve is compared to the expected shape. Any significant deviation causes a warning, This criterion can only be checked with sufficient SNR (> 7 dB). 	Peak Level > QC	
Peak Location	<ul style="list-style-type: none"> The physical location of the sampling volume is compared to the expected location. Any significant deviation causes a warning. This criterion can only be checked for sufficient SNR (> 7 dB). 	Peak Location > QC	
Temperature	<ul style="list-style-type: none"> No criteria defined for Temperature. Temperature data included in Automated BeamCheck to allow user to analyze data before measurement. 	None	

- a) The graphical display of the Quality Control parameters supplied during the Automated BeamCheck is time series of each parameter. If there are any significant variation between the beams, spikes are present in the data or Quality Control warnings are issued we recommend the following steps,
 - i). Repeat the test at least once, after you verify that the probe and sampling volume are well away from any underwater obstacles.
 - ii). Perform BeamCheck, described in [6.3 Beam Check](#) to evaluate FlowTracker2 performance in more detail.

- b) The display options for individual or all beam check data are listed in [Table 9:2](#). The shortcut key on the keypad determines which beam SNR will be displayed,

Table 9-2 - Automated Beam Check Display

Beam	Line Color	Keypad Key
Beam1	Red	1
Beam2	Blue	2
Beam3	Green	3
All Beams	All	4

c) *To select a Quality Control Criteria,*

i). Use up or down scroll arrows keys to view quality control criteria.

9.3. Data Collection

Data Collection function for General mode is the process involved in collecting velocity data. The data collection process is a systematic workflow designed to follow the actual measurement process in the field. The process consist of the following main components that also describes each individual aspect of the field measurement,

- Data Collection Window,
- Station Measurement,
- Data Collection Menu.

9.3.1 Data Collection Window

The **Data Collection Window** can be defined as the “*control center*” of the data collection process during velocity measurements. All the software functions required to perform velocity measurements is available from the data collection screen. The key features and some of the variables are explained in **Figure 9:6**.

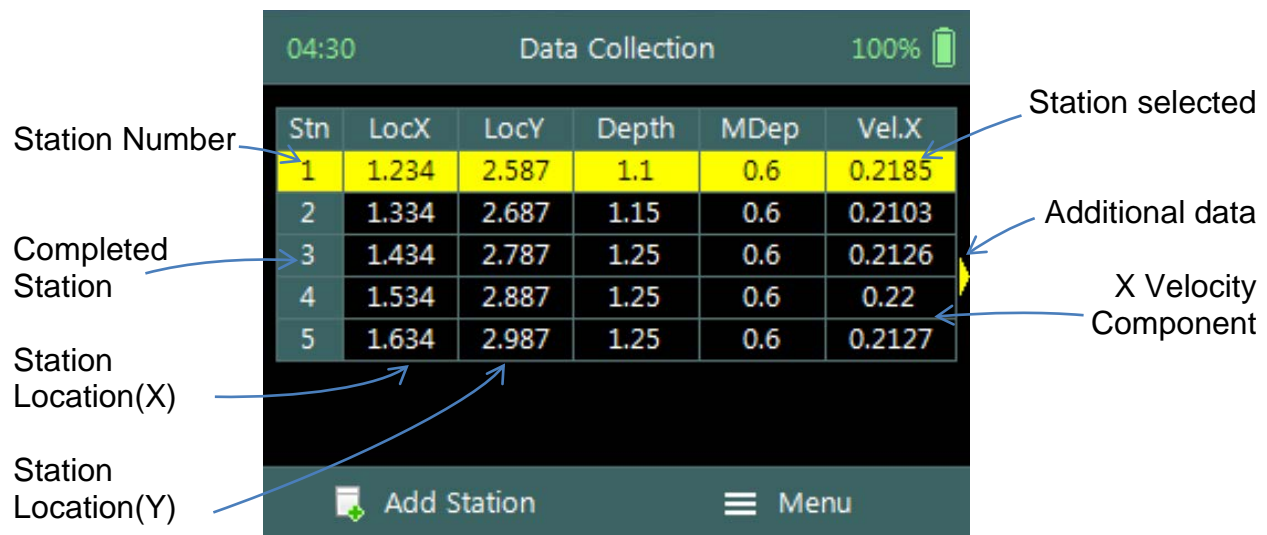

Figure 9:6 - Data Collection Window

The operations and functions available of the Data Collection Window will be discussed throughout this section with the main functions described in **Figure 9:7**.

Data Collection Window screen of the consists of the following,

- a) Station Management area defined in **rectangle**,
- b) Add Station,
- c) Data Collection Menu (*Menu*).
- d) To **add** a station,
 - i). Press the Left Soft Key.
- e) To **select** the data collection **menu**,
 - i). Press the Right Soft Key,
 - ii). The software will display a popup menu screen.

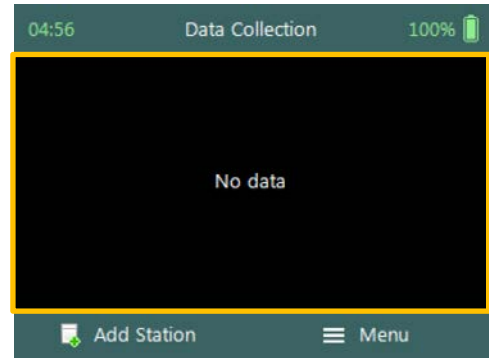

Figure 9:7 - Functions Data Collection Window

9.3.1.1 Add Station

Add Station function creates a station for each measurement location identified for velocity measurements. The process separates point velocity measurements with the same position and or different measurement locations.

Add Station screen consist of the following parameters that are required to create a station,

- a) Location X,
- b) Location Y,
- c) Water Depth,
- d) Measurement Depth,
- e) Comment.

The standard **functions** available for each station type are,

- f) Record GPS Location (function availability, see [GPS Station Tagging](#)).
- g) To **add** a station or start velocity measurement,
 - i). Press the Right Soft Key.
- h) To **CANCEL** add station,
 - i). Press the Left Soft Key.

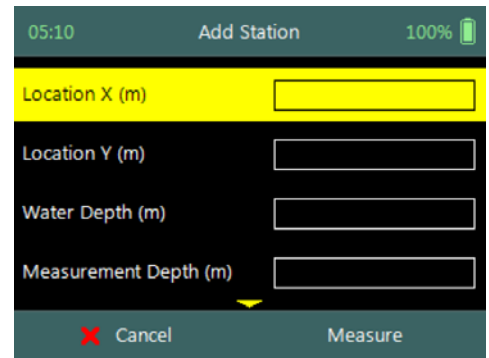

Figure 9:8 - Add Station



Unique station number is assigned to each point velocity measurement. This allows the user to perform multiple measurements at the same location without assigning a unique number or name to differentiate between the measurements.

Properties associated with the parameters for station are defined in [Table 9:3](#),

Table 9-3 - Station - Properties

Parameter	Min	Max	Default	Decimals	Units	Required
Location X	-1000	1000	empty	3	m or ft	Yes
Location Y	-1000	1000	empty	3	m or ft	Yes
Water Depth	0	100	empty	3	m or ft	Yes

Parameter	Min	Max	Default	Decimals	Units	Required
Measurement Depth	0	100	empty	3	m or ft	Yes
Comment	0	250	empty			No

9.3.1.2 Delete Station

Deleting a station is performed from the **Data Collection Window** by selecting the station within the viewable window.



The station delete process is not reversible and the user must ensure that the correct station is selected. Selected station will be highlighted with a yellow background.

Delete Station is performed from the **Data Collection Window**. Up to ten completed stations will be displayed at any time,

- a) *To select a station,*
 - i). Use the up or down arrow key to scroll through the completed stations,
- b) *To **DELETE** a station,*
 - i). Press the backspace key.
 - ii). The software will navigate to the Confirmation screen.

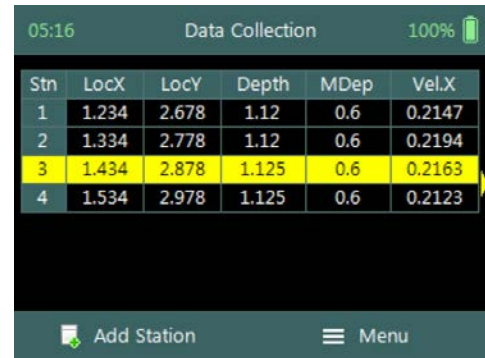

Figure 9:9 - Select Station

Confirmation screen requests confirmation of deleting the selected station.

- a) *To confirm station delete,*
 - i). Press the Right Soft Key,
- b) *To **CANCEL** station delete,*
 - i). Press the Left Soft Key,
- c) *The software will navigate to the Data Collection Window.*

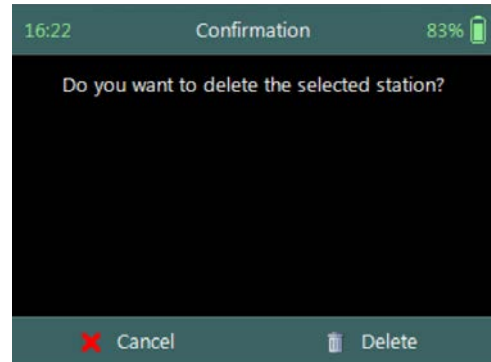

Figure 9:10 - Confirm Delete

9.3.2 Station Measurement (Wading Rod)

Station Measurement is performed at each Station based on measurement requirements. The measurement locations can either be structured such in laboratory environment where the position of the instrument is determined accurately or random where velocities on channel banks are investigated. The station measurements consist of collecting a number of different parameters and variables required by the General mode.

9.3.2.1 Point Velocity Measurement

Point Velocity Measurement in General mode is not bound to any measurement techniques and or guidelines as required in Discharge mode. The location of the station, number of point velocity measurements and depth of point velocity measurements is dependent on the user requirements.



If the velocity measurements are used to perform hydraulic analyzes of the flow conditions in a channel, either a laboratory or natural channel, it is recommended that ISO 748 – 2007 guidelines are used.

Step 1

Station parameters defined for **Velocity Measurement**, e.g., parameters of station defined for velocity measurement are the following,

- Location X: 1.534m,
- Location Y: 2.978m,
- Water Depth: 1,125m,
- Measurement Depth: 0.6m,
- Velocity Method: Two Point,
- Comment.
- To **add** station and continue velocity measurement,
 - Press the Right Soft Key.
- To **CANCEL** a new station,
 - Press the Left Soft Key.

18:08 Add Station #1 83%

Location X (m)	1.534
Location Y (m)	2.978
Water Depth (m)	1.125
Measurement Depth (m)	0.6

Cancel Measure

Figure 9:11 - Velocity Measurement

Step 2

Setting Measurement Depth screen allow the setting and placement of the wading rod before velocity measurement is started,

- Wading rod setting,
- Beam Check,
- SNR,
- Tilt,
- Velocity angle.
- To **start** a velocity measurement,
 - Press the Right Soft Key.
- To **REVERT** to measurement screen,
 - Press the Left Soft Key.

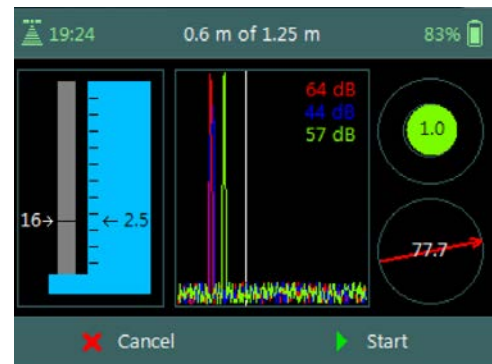

Figure 9:12 - Setting Measurement Depth

The key features of the **Setting Measurement Depth** are explained in [Figure 9:13](#).

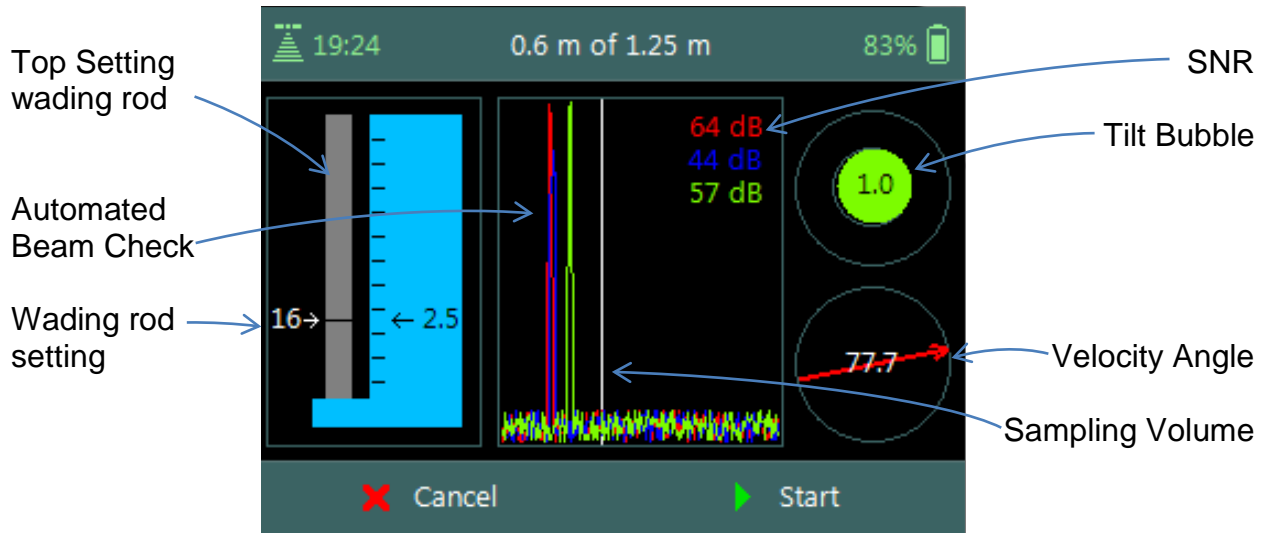

Figure 9:13 - Features of Setting Measurement Depth

The Sampling Volume of the instrument is defined by the white vertical line displayed on the Beam Profile plot in Figure 9:13. The location of the line is fixed and is based on the geometry of the beams. This is an excellent guide to indicate if the boundary is too close to the sampling volume.

Step 4

Velocity Measurement screen displays graphical display of raw data of the following variables during a velocity measurement,

- a) Velocity,
- b) SNR,
- c) Temperature,
- d) Battery,
- e) Tilt,

Tilt and Velocity Angle indicators are situated on the right hand side of the screen.

- f) Tilt,
- g) Velocity Angle,
- h) Averaging Time left.
- i) *To select a variable graphical display,*
 - i). Use up or down scroll arrows keys.
- j) *To stop sampling,*
 - i). Press the Right Soft Key.
- k) *To CANCEL velocity measurement,*
 - i). Press the Left Soft Key.

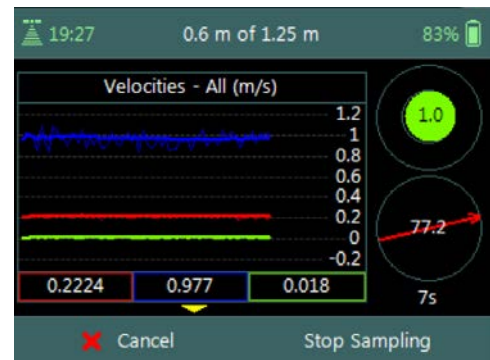

Figure 9:14 - Velocity Measurement

The conventions and graphic display features used for displaying Velocity and SNR raw data are defined under [Raw Data Display](#).

9.3.2.2 Review Point Measurement

Review Point Measurement is a report supplied at the end of each point velocity measurement. The report consists of two components, tabular summary of numerical calculations performed on the raw data collected and graphical display of raw data.

Review Point Measurement screen consists of the following tabular summary and graphical displays,

Tabular Display

- a) Review Point Measurement, [Table 9:4](#)

Graphical Display of raw data are based on the following variables,

- b) Velocity,
- c) SNR,
- d) Temperature,
- e) Tilt,
- f) Velocity Angle,
- g) Battery.
- h) *To select a variable,*
 - i). Use the up or down arrow key to view a variable,
- i) *To accept the velocity measurement,*
 - i). Press the Right Soft Key.
- j) *To REDO velocity measurement,*
 - i). Press the Left Soft Key.

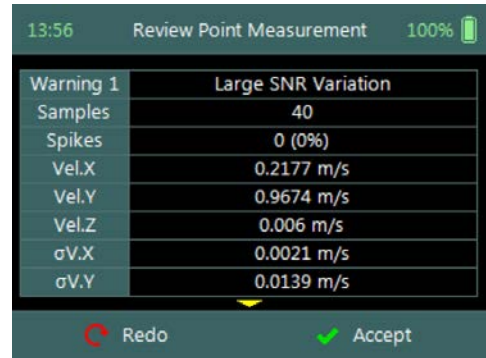

Figure 9:15 - Review Point Measurement



The conventions and graphic display features used for displaying Velocity and SNR raw data are defined under [Raw Data Display](#).

Properties associated with the variable output from the numerical calculations performed on raw data collected is defined in [Table 9:4](#),

Table 9-4 - Review Point Measurement

Variable	Description	Units	Decimal
Warning	Warning supplied based on quality control criteria	n/a	n/a
Samples	Total number of sample received	number	n/a
Spikes	Number of spikes removed from mean velocity	number	n/a
Vel. X	Mean X velocity component of all samples. Velocity is despiked and mounting correction applied (if applicable).	m/s or ft/s	4
Vel. Y	Mean Y velocity component of all samples. Velocity is despiked and mounting correction applied (if applicable).	m/s or ft/s	4

Variable	Description	Units	Decimal
Vel. Z	Mean Z velocity component of all samples. Velocity is despiked and mounting correction applied (if applicable).	m/s or ft/s	4
σV. X	Standard error of X velocity component.	m/s or ft/s	4
σV. Y	Standard error of Y velocity component.	m/s or ft/s	4
σV. Z	Standard error of Z velocity component.	m/s or ft/s	4
SNR. 1	Signal to noise ratio of Beam 1	dB	3
SNR. 2	Signal to noise ratio of Beam 2	dB	3
SNR. 3	Signal to noise ratio of Beam 3	dB	3
Angle	Flow angle relative to X direction	Degree	2
Bnd	Boundary QC value	n/a	n/a
Tilt	Mean wading rod angle during point velocity measurement	Degree	2
Temp	Mean temperature during measurement	°C or °F	2

9.3.2.3 Review Station Measurement

Review Station measurement is a tabular report that is available from the data collection window at the completion of point velocity measurement of a station.

Review Station screen consists of tabular summary of measurements performed at the station,

- a) Review Station, [Table 9:5](#).
- b) *To access review station report,*
 - i). Select the station in the data collection window,
 - ii). Press the enter key.
- c) *To EXIT review station report,*
 - i). Press the Left Soft Key.

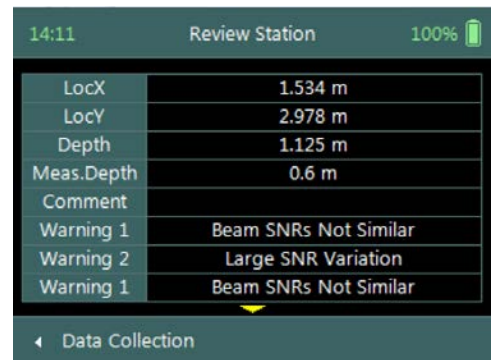

Figure 9:16 - Review Station

Properties associated with the variables and numerical calculations performed on the raw data collected at the station is defined in [Table 9:5](#),

Table 9-5 - Review Station

Variable	Description	Units	Decimal
Loc X	Location X coordinate	m or ft	3
Loc Y	Location Y coordinate	m or ft	3
Depth	Measured water depth	m or ft	3
Meas. Depth	Velocity measurement depth	m or ft	3
Comment	Comment supplied before the measurement	n/a	n/a
Warning	Warning supplied based on quality control criteria	n/a	n/a
Samples	Total number of sample received	number	n/a
Spikes	Number of spikes removed from mean velocity	number	n/a

Variable	Description	Units	Decimal
Vel. X	Mean X velocity component of all samples. Velocity is despiked and mounting correction applied (if applicable).	m/s or ft/s	4
Vel. Y	Mean Y velocity component of all samples. Velocity is despiked and mounting correction applied (if applicable).	m/s or ft/s	4
Vel. Z	Mean Z velocity component of all samples. Velocity is despiked and mounting correction applied (if applicable).	m/s or ft/s	4
σV. X	Standard error of X velocity component.	m/s or ft/s	4
σV. Y	Standard error of Y velocity component.	m/s or ft/s	4
σV. Z	Standard error of Z velocity component.	m/s or ft/s	4
SNR. 1	Signal to noise ratio of Beam 1	dB	3
SNR. 2	Signal to noise ratio of Beam 2	dB	3
SNR. 3	Signal to noise ratio of Beam 3	dB	3
Angle	Flow angle relative to X direction	Degree	2
Bnd	Boundary QC value	n/a	n/a
Tilt	Mean wading rod angle during velocity measurement	Degree	2
Temp	Mean temperature during measurement	°C or °F	2
GPS - Latitude	GPS derived Latitude	DDD° MM' SS.SS	
GPS - Longitude	GPS derived Longitude	DDD° MM' SS.SS	

9.3.3 Station Measurement (Pressure Sensor)

Station Measurement is performed at each Station based on measurement requirements. The measurement locations can either be structured such in laboratory environment where the position of the instrument is determined accurately or random where velocities on channel banks are investigated. The station measurements consist of collecting a number of different parameters and variables required by the General mode.

9.3.3.1 Point Velocity Measurement

Point Velocity Measurement in General mode is not bound to any measurement techniques and or guidelines as required in Discharge mode. The location of the station, number of point velocity measurements and depth of point velocity measurements is dependent on the user requirements.



If the velocity measurements are used to perform hydraulic analyzes of the flow conditions in a channel, either a laboratory or natural channel, it is recommended that ISO 748 – 2007 guidelines are used.

Step 1

Station parameters defined for **Velocity Measurement**, e.g., parameters of station defined for velocity measurement are the following,

- a) Location X: 1.534m,
- b) Location Y: 2.978m,
- c) Water Depth: 1,125m,
- d) Measurement Depth: 0.6m,
- e) Velocity Method: Two Point,
- f) Comment.
- g) To **add** station and continue velocity measurement,
 - i). Press the Right Soft Key.
- h) To **CANCEL** a new station,
 - i). Press the Left Soft Key.

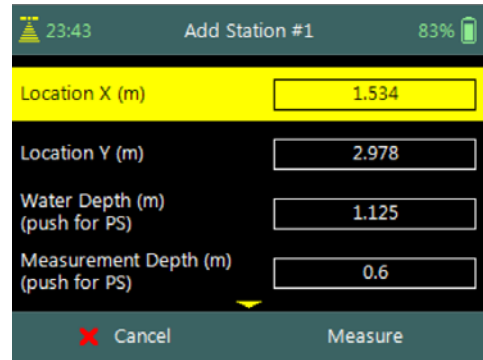

Figure 9:17 - Velocity Measurement



The water depth at each station can either be based on pressure sensor measurements or manually entered by the user. To perform pressure sensor measurement the Enter Key is pressed on the Water Depth and Measurement Depth parameter.

Step 2

Pressure Sensor (PS) Calibration allows the user to perform pressure sensor calibration. The screen is displayed before the first pressure sensor measurement is performed or when the **Air Pressure Cal. Period** expired.

- a) To perform PS Calibration,
 - i). Press the Right Soft Key.
- b) To **CANCEL** PS Calibration,
 - i). Press the Left Soft Key.

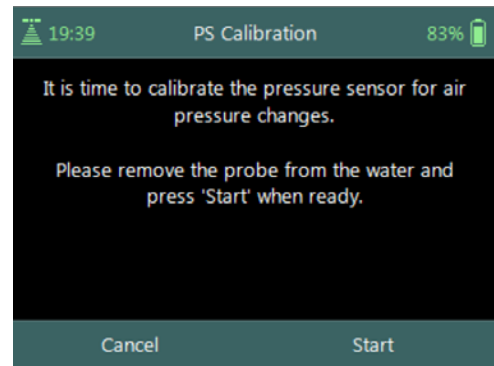

Figure 9:18 - PS Calibration

Step 3

Pressure Sensor (PS) Total Depth screen allows the user to perform depth measurement. The tilt sensor or bubble should be used to keep the instrument vertical.

- a) To perform Depth Measurement,
 - i). Press the Right Soft Key.
- b) To **CANCEL** PS Calibration,
 - i). Press the Left Soft Key.

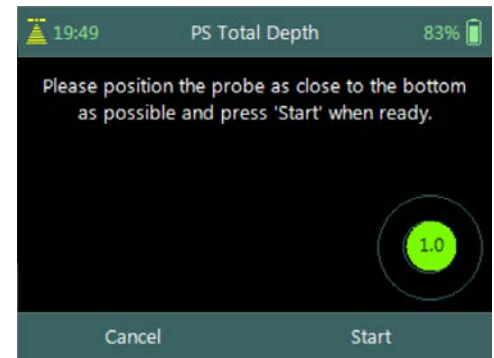

Figure 9:19 - PS Total Depth



The FlowTracker2 ADV Probe should be kept vertical during the pressure sensor measurements. Any angle on the probe will impact the pressure sensor measurements because the probe is off center of the wading rod.

Step 4

Pressure Sensor (PS) Instrument Depth screen allows the user to perform instrument depth measurement. The tilt sensor or bubble should be used to keep the instrument vertical.

- a) To perform Instrument Depth Measurement,
 - i). Press the Right Soft Key.
- b) To **CANCEL** Instrument Depth Measurement,
 - i). Press the Left Soft Key.



Figure 9:20 - PS Instrument Depth

Step 5

Setting Measurement Depth screen allow the adjustment of the pressure sensor before velocity measurement is started,

- a) Pressure Sensor Depth Guide,
- b) Beam Check,
- c) SNR,
- d) Tilt,
- e) Velocity angle.
- f) To **start** a velocity measurement,
 - ii). Press the Right Soft Key.
- g) To **REVERT** to measurement screen,
 - ii). Press the Left Soft Key.



Figure 9:21 - Setting Measurement Depth

The key features of the **Setting Measurement Depth** are explained in [Figure 9:22](#).

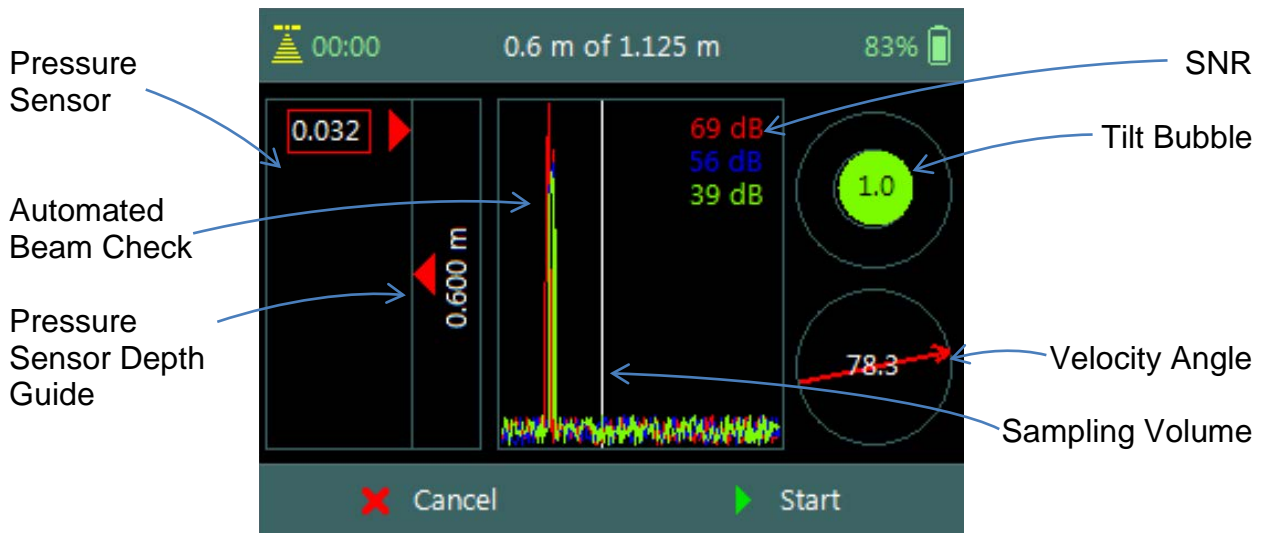

Figure 9:22 - Features of Setting Measurement Depth



The Sampling Volume of the instrument is defined by the white vertical line displayed on the Beam Profile plot in Figure 9:22. The location of the line is fixed and is based on the geometry of the beams. This is an excellent guide to indicate if the boundary is too

close to the sampling volume.

Step 4

Velocity Measurement screen displays graphical display of raw data of the following variables during a velocity measurement,

- a) Velocity,
- b) SNR,
- c) Temperature,
- d) Tilt,
- e) Vel. Angle,
- f) Probe Depth,
- g) Battery,
- h) Pressure.

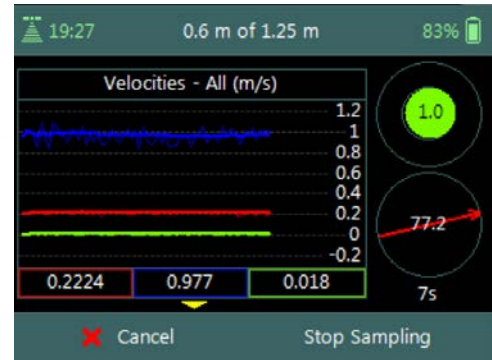

Figure 9:23 - Velocity Measurement

Tilt and Velocity Angle indicators are situated on the right hand side of the screen.

- i) Tilt,
- j) Velocity Angle,
- k) Averaging Time left.
- l) *To select a variable graphical display,*
 - i). Use up or down scroll arrows keys.
- m) *To stop sampling,*
 - i). Press the Right Soft Key.
- n) *To CANCEL velocity measurement,*
 - i). Press the Left Soft Key.



The conventions and graphic display features used for displaying Velocity and SNR raw data are defined under [Raw Data Display](#).

9.3.3.2 Review Point Measurement

Review Point Measurement is a report supplied at the end of each point velocity measurement. The report consists of two components, tabular summary of numerical calculations performed on the raw data collected and graphical display of raw data.

Review Point Measurement screen consists of the following tabular summary and graphical displays,

Tabular Display

- a) Review Point Measurement, [Table 9:6](#)

Graphical Display of raw data are based on the following variables,

- b) Velocity,
- c) SNR,
- d) Temperature,

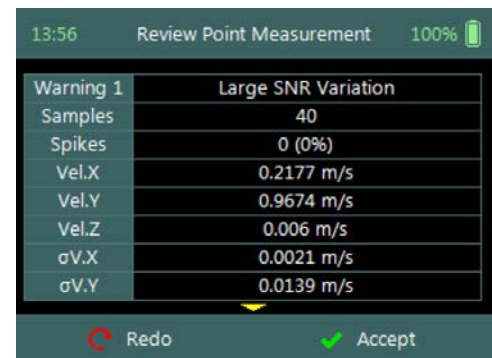

Figure 9:24 - Review Point

- Measurement**
- e) Tilt,
 - f) Velocity Angle,
 - g) Probe Depth,
 - h) Battery,
 - i) Pressure.
 - j) *To **select** a variable,*
 - i). Use the up or down arrow key to view a variable,
 - k) *To **accept** the velocity measurement,*
 - i). Press the Right Soft Key.
 - l) *To **REDO** velocity measurement,*
 - i). Press the Left Soft Key.



The conventions and graphic display features used for displaying Velocity and SNR raw data are defined under [Raw Data Display](#).

Properties associated with the variable output from the numerical calculations performed on raw data collected is defined in [Table 9:6](#),

Table 9-6 - Review Point Measurement

Variable	Description	Units	Decimal
Warning	Warning supplied based on quality control criteria	n/a	n/a
Samples	Total number of sample received	number	n/a
Spikes	Number of spikes removed from mean velocity	number	n/a
Vel. X	Mean X velocity component of all samples. Velocity is despiked and mounting correction applied (if applicable).	m/s or ft/s	4
Vel. Y	Mean Y velocity component of all samples. Velocity is despiked and mounting correction applied (if applicable).	m/s or ft/s	4
Vel. Z	Mean Z velocity component of all samples. Velocity is despiked and mounting correction applied (if applicable).	m/s or ft/s	4
σV. X	Standard error of X velocity component.	m/s or ft/s	4
σV. Y	Standard error of Y velocity component.	m/s or ft/s	4
σV. Z	Standard error of Z velocity component.	m/s or ft/s	4
SNR. 1	Signal to noise ratio of Beam 1	dB	3
SNR. 2	Signal to noise ratio of Beam 2	dB	3
SNR. 3	Signal to noise ratio of Beam 3	dB	3
Angle	Flow angle relative to X direction	Degree	2
Bnd	Boundary QC value	n/a	n/a
Tilt	Mean wading rod angle during point velocity measurement	Degree	2

Variable	Description	Units	Decimal
Temp	Mean temperature during measurement	°C or °F	2
Depth	Mean water depth from water surface during point measurement	m or ft	3
Pressure	Mean water pressure during point measurement	dbar	3

9.3.3.3 Review Station Measurement

Review Station measurement is a tabular report that is available from the data collection window at the completion of point velocity measurement of a station.

Review Station screen consists of tabular summary of measurements performed at the station,

- a) Review Station, [Table 9:7](#).
- b) To *access review station report*,
 - i). Select the station in the data collection window,
 - ii). Press the enter key.
- c) To *EXIT review station report*,
 - i). Press the Left Soft Key.

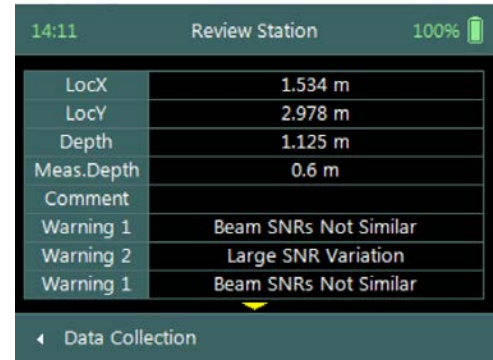

Figure 9:25 - Review Station

Properties associated with the variables and numerical calculations performed on the raw data collected at the station is defined in [Table 9:7](#),

Table 9-7 - Review Station

Variable	Description	Units	Decimal
Loc X	Location X coordinate	m or ft	3
Loc Y	Location Y coordinate	m or ft	3
Depth	Measured water depth	m or ft	3
Meas. Depth	Velocity measurement depth	m or ft	3
Comment	Comment supplied before the measurement	n/a	n/a
Warning	Warning supplied based on quality control criteria	n/a	n/a
Samples	Total number of sample received	number	n/a
Spikes	Number of spikes removed from mean velocity	number	n/a
Vel. X	Mean X velocity component of all samples. Velocity is despiked and mounting correction applied (if applicable).	m/s or ft/s	4
Vel. Y	Mean Y velocity component of all samples. Velocity is despiked and mounting correction applied (if applicable).	m/s or ft/s	4
Vel. Z	Mean Z velocity component of all samples. Velocity is despiked and mounting correction applied (if applicable).	m/s or ft/s	4
σV. X	Standard error of X velocity component.	m/s or ft/s	4

Variable	Description	Units	Decimal
$\sigma V. Y$	Standard error of Y velocity component.	m/s or ft/s	4
$\sigma V. Z$	Standard error of Z velocity component.	m/s or ft/s	4
SNR. 1	Signal to noise ratio of Beam 1	dB	3
SNR. 2	Signal to noise ratio of Beam 2	dB	3
SNR. 3	Signal to noise ratio of Beam 3	dB	3
Angle	Flow angle relative to X direction	Degree	2
Bnd	Boundary QC value	n/a	n/a
Tilt	Mean wading rod angle during velocity measurement	Degree	2
Temp	Mean temperature during measurement	°C or °F	2
Depth	Mean water depth from water surface during point measurement	m or ft	3
Pressure	Mean water pressure during point measurement	dbar	3
GPS - Latitude	GPS derived Latitude	DDD° MM' SS.SS	
GPS - Longitude	GPS derived Longitude	DDD° MM' SS.SS	

9.3.4 Data Collection Menu

Data Collection Menu allows the user to adjust measurement settings, view measurement summary, perform automated beam check and complete the measurement. The data collection menu can be accessed between station measurements and this ensures that the instrument is configured for current flow conditions present.

Data Collection Menu screen consists of the following functions that are available in General Mode,

- a) Settings,
- b) Summary,
- c) Automated Beam Check,
- d) PS Calibration,
- e) Complete Measurement,
- f) Discard Measurement,
- g) Go to Home Screen.
- h) *To select a function,*
 - i). Use the up or down arrow key to scroll through the functions,
- i) *To open or **CLOSE** the data collection menu,*
 - i). Press the Right Soft Key.

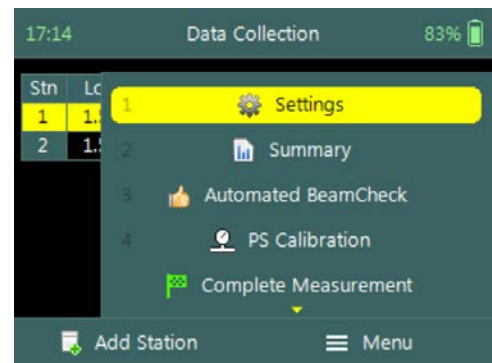

Figure 9:26 - Data Collection Menu

9.3.4.1 Settings

The **Settings** menu option gives the user access to the initial measurement settings that were configured during the configuration of the general template.

Settings screen consists of the following functions for configuring measurement settings,

- a) File Properties,
- b) Data Collection Settings,
- c) Quality Control Settings.
- d) *To select a function,*
 - i). Use the up or down arrow key to scroll through the functions,
- e) *To **CLOSE** the settings menu,*
 - i). Press the Left Soft Key.

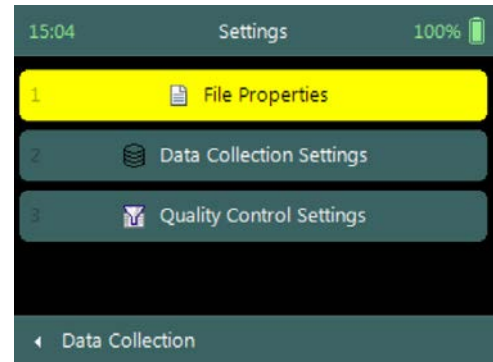

Figure 9:27 - Settings Menu



The measurement settings functions supplied in the Settings option in data collection menu are defined under [Template Functions](#).

9.3.4.2 Velocity Summary

Velocity Summary from the data collection menu displays the mean velocity and other variables measured from all completed stations. The velocity summary requires at least one station with velocity measurements to populate the main variables in the table.

Velocity Summary screen consists of tabular summary of velocity and other variables measured up to specific point,

- a) Velocity Summary, [Table 9:8](#).
- b) *To **close** the velocity summary report,*
 - i). Press the Left Soft Key,
 - ii). The software will navigate to the Data Collection Window.

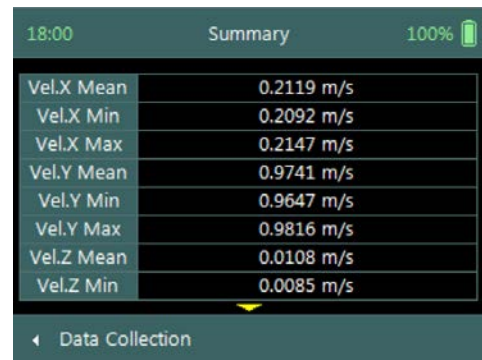

Figure 9:28 - Velocity Summary

Properties associated with the variables and numerical calculations performed on the raw data collected is defined in [Table 9:8](#),

Table 9-8 - Velocity Summary

Variable	Description	Units	Decimal
Vel. X Mean	Average station velocity, X velocity component of all stations.	m/s or ft/s	4
Vel. X Min	Minimum station velocity, X velocity component.	m/s or ft/s	4
Vel. X Max	Maximum station velocity, X velocity	m/s or ft/s	4

Variable	Description	Units	Decimal
	component.		
Vel. Y Mean	Average station velocity, Y velocity component of all stations.	m/s or ft/s	4
Vel. Y Min	Minimum station velocity, Y velocity component.	m/s or ft/s	4
Vel. Y Max	Maximum station velocity, Y velocity component.	m/s or ft/s	4
Vel. Z Mean	Average station velocity, Z velocity component of all stations.	m/s or ft/s	4
Vel. Z Min	Minimum station velocity, Z velocity component.	m/s or ft/s	4
Vel. Z Max	Maximum station velocity, Z velocity component.	m/s or ft/s	4
σV. Mean	Average standard error, X velocity component of all stations.	m/s or ft/s	4
σV. Min	Minimum standard error, X velocity component of all stations.	m/s or ft/s	4
σV. Max	Maximum standard error, X velocity component of all stations.	m/s or ft/s	4
SNR Mean	Average SNR of all stations.	dB	2

9.3.4.3 Automated Beam Check

Automated Beam Check function in the data collection menu allows the user to perform beam check during any stage of the velocity measurement. The Automated Beam Check function operations, conventions and graphic display features are defined under [Automated Beam Check](#).



Automated Beam Checks performed during the discharge measurement are stored in FlowTracker2 file (.ft) that was created for the measurement site.

9.3.4.4 PS Calibration ([Pressure Sensor](#))

The **PS Calibration** function in the data collection menu allows the user to perform Pressure Sensor Calibration during any stage between point velocity measurements.



Frequent calibration of pressure sensor for atmospheric or air pressure changes during the measurement will improve the accuracy of pressure measurements. The variation in atmospheric or air pressure will impact the accuracy of pressure measurements.

Step 1

PS Calibration screen allows the user to perform pressure sensor calibration. The user is required to remove the probe from the water.

- a) *To perform PS Calibration,*
 - i). Press the Right Soft Key.
- b) *To **CANCEL** PS Calibration,*
 - i). Press the Left Soft Key.

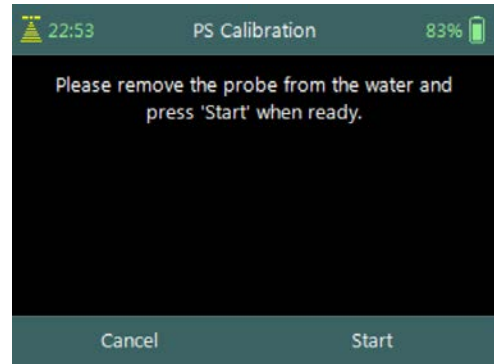

Figure 8:29 – PS calibration

Step2

PS Calibration screen with **Quality Control** warning messages based on quality control checks performed on measurement data.

- a) *To **accept** quality control warning messages,*
 - i). Press the Right Soft Key.
- b) *To **REDO** PS Calibration,*
 - i). Press the Left Soft Key.

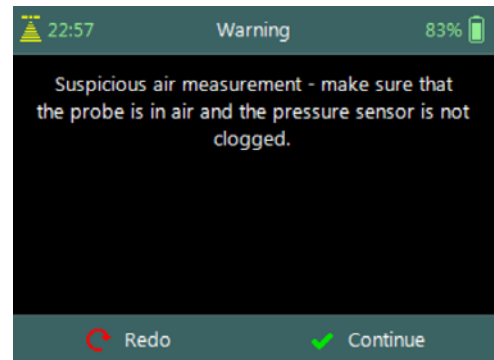

Figure 8:30 - Warning Messages

9.3.4.5 Complete Measurement

The **Complete Measurement** function closes the measurement file and the user will not be able to add additional stations and or make any changes to the data captured. The complete measurement function is a three-step process, firstly to determine if the user is satisfied with the velocity measurements, secondly to perform quality control checks against all measurement data and lastly to review measurement summary.



The Complete Measurement process allows the user to review the measurement data before the complete function is selected at Summary screen. The user will not be able to make any to changes to the measurement file from the handheld when this function is selected.

Step 1

Confirmation screen of **Complete Measurement** function confirms if the user wants to close the measurement file. User will not be able to add stations or make any changes to the data

- a) *To **confirm** complete measurement operation,*
 - i). Press the Right Soft Key.
- b) *To **CANCEL** complete measurement operation,*
 - i). Press the Left Soft Key.

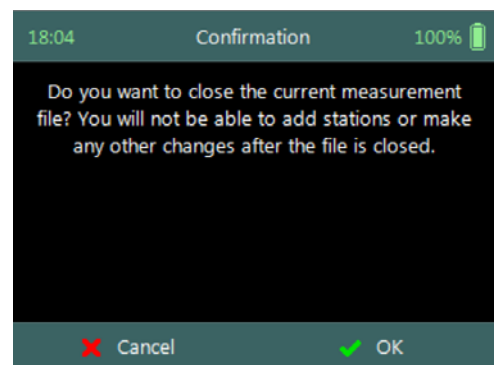

Figure 9:31 - Confirmation

Complete Measurement

Step2

Confirmation screen with **Quality Control** warning messages based on quality control checks performed on measurement data.

- a) To **accept** quality control warning messages,
 - i). Press the Right Soft Key.
- b) To **CANCEL** complete measurement operation,
 - i). Press the Left Soft Key.

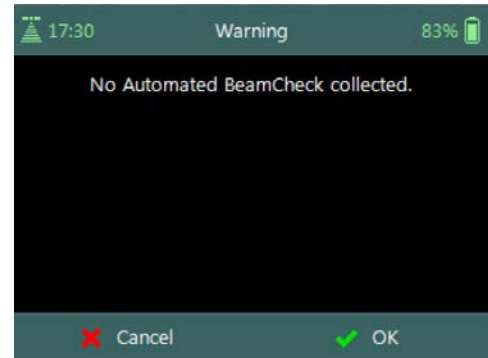

Figure 9:32 - Confirmation Quality Control Messages

Step3

Summary screen displays the velocity summary report before the measurement file is closed for further data entry and editing.

- a) To **confirm** complete measurement operation,
 - i). Press the Right Soft Key,
 - ii). The software will navigate to the Main Menu.
- b) To **CANCEL** complete measurement operation,
 - i). Press the Left Soft Key.

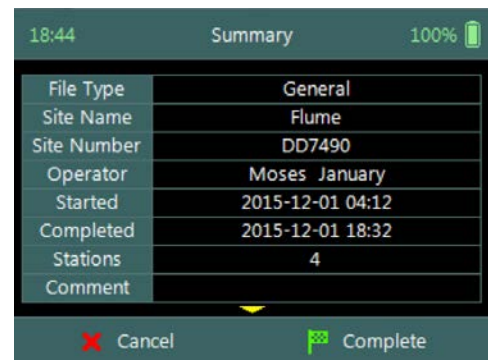

Figure 9:33 - Summary Discharge Measurement

9.3.4.6 Discard Measurement

The **Discard Measurement** function will discard all configuration settings, stations and other data related with the measurement.



Discarding a measurement will result in deleting all data of the measurement site that is related to the specific measurement file.

Warning screen of **Discard Measurement** function displays the warnings associated with discarding measurement file.

- a) To **DISCARD** measurement,
 - i). Press the Right Soft Key.
 - ii). The software will navigate to the Main Menu.
- b) To **CANCEL** discard measurement operation,
 - i). Press the Left Soft Key.

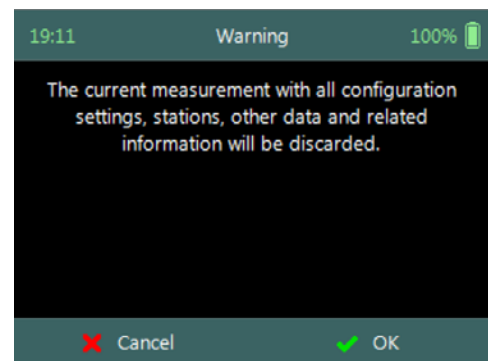

Figure 9:34 - Warning Discard Measurement

9.3.4.7 Go to Home Screen

The **Go to Home Screen** function will navigate the software to the main menu and the user will have the ability to access software functions that are not related to General Mode function.



The velocity measurements can be accessed during any stage by selecting the “Data Collection” function with the Right Soft Key. The software will continue with the measurement at the exact stage when the user navigated away from the general mode.

9.4. Measurement Summary

Measurement Summary is supplied when the Complete Measurement function is selected and displays all the measurement results. The Measurement Summary is the last verification of the measurement results before the measurement file is closed for any further measurements or changes.

Measurement Summary screen consists of tabular summary of velocity measurement results,

- a) Velocity Summary, [Table 9:9](#).
- b) To **CANCEL** the general summary report,
 - i). Press the Left Soft Key.
 - ii). The software will navigate to the Data Collection Window.
- c) To **COMPLETE** the general measurement,
 - i). Press the Right Soft Key.
 - ii). The software will close the measurement file and navigate to the main menu.

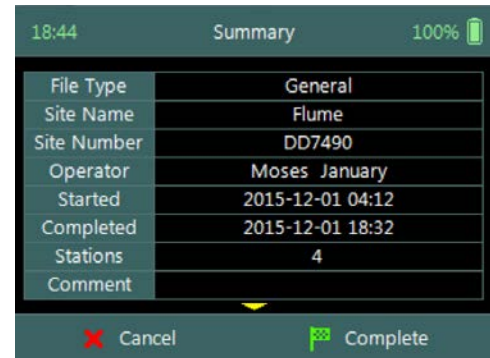

Figure 9:35 - Measurement Summary

Properties associated with the variables and numerical calculations performed on the raw data collected is defined in [Table 9:9](#),

Table 9-9 - Measurement Summary

Variable	Description	Units	Decimal
File Type	File type based on discharge or general mode	n/a	n/a
Site Name	Site name populated by user	n/a	n/a
Site Number	Site number populated by user	n/a	n/a
Operator	Operator name populated by user	n/a	n/a
Started	Start date and time when measurement was created	yyyy-mm-dd hh:mm	
Completed	End data and time when measurement was completed	yyyy-mm-dd hh:mm	
Stations	Total number of stations within the measurement	n/a	n/a

Variable	Description	Units	Decimal
Comment	General comment captured against measurement	n/a	n/a
Vel. X Mean	Average station velocity, X velocity component of all stations.	m/s or ft/s	4
Vel. X Min	Minimum station velocity, X velocity component.	m/s or ft/s	4
Vel. X Max	Maximum station velocity, X velocity component.	m/s or ft/s	4
Vel. Y Mean	Average station velocity, Y velocity component of all stations.	m/s or ft/s	4
Vel. Y Min	Minimum station velocity, Y velocity component.	m/s or ft/s	4
Vel. Y Max	Maximum station velocity, Y velocity component.	m/s or ft/s	4
Vel. Z Mean	Average station velocity, Z velocity component of all stations.	m/s or ft/s	4
Vel. Z Min	Minimum station velocity, Z velocity component.	m/s or ft/s	4
Vel. Z Max	Maximum station velocity, Z velocity component.	m/s or ft/s	4
σV. Mean	Average standard error, X velocity component of all stations.	m/s or ft/s	4
σV. Min	Minimum standard error, X velocity component of all stations.	m/s or ft/s	4
σV. Max	Maximum standard error, X velocity component of all stations.	m/s or ft/s	4
SNR Mean	Average SNR of all stations.	dB	2
GPS - Latitude	GPS derived Latitude	DDD° MM' SS.SS	
GPS - Longitude	GPS derived Longitude	DDD° MM' SS.SS	

Section 10. FlowTracker2 Hardware

10.1. ADV Probe

The FlowTracker2 ADV Probe and internal sensors that were implemented specifications are listed in [Table 10:1](#),



Table 10-1- ADV Probe Specifications

Hardware		Specification	
Velocity Range		±0.001 to 4.0m/s (0.003 to 13ft/s)	
Velocity Resolution		0.0001m/s (0.0003ft/s)	
Velocity Accuracy		±1% of measured velocity, 0.25 cm/s	
Acoustic Frequency		10.0MHz	
Sampling Volume Location		10cm (3.93in) from the center transducer	
Minimum Depth		0.02m (0.79in)	
Depth Measurement Range		0 to 10m (0 to 32.81ft)	
Depth Measurement Resolution		0.001m (0.003ft)	
Depth Sensor Accuracy		i). +/- 0.1% of FS (temperature compensated over full operating range), ii). +/- 0.05% Static (steady-state at 25C), iii). Additionally compensated for real-time water velocity, temperature, salinity, and altitude.	
Temperature Sensor		Resolution: 0.01°C, Accuracy: 0.1°C	
Tilt Sensor		Accuracy: 1.0°	
Communication Protocol		RS-232	
Temperature	Operating	Alkaline	-20° to 45°C (-4°F to 113°F)
		NiMH	-20° to 50°C (-4°F to 122°F)
	Storage	-30° to 70°C (-22°F to 158°F)	
		Remove batteries from FlowTracker2 handheld if storage temperatures exceed the operating temperature of Alkaline and NiMH batteries as stipulated above.	
Physical Specifications	Probe Head Dimensions	No Pressure Sensor	(L)13.3cm (5.22in); (W) 6.1cm (2.39in); (H) 2.3cm (0.90in)
		Pressure Sensor	(L) 13.3cm (5.22in); (W)6.9cm (2.72in); (H)2.3cm (0.90in)
	Standard Cable Length	1.500m (4.92ft)	
	Weight in Air	0.90kg (1.98lbs)	
	Weight in Water	0.30kg (0.66lbs)	

10.2. Handheld

The FlowTracker2 Handheld and internal sensors implemented specifications are listed in [Table 10:2](#),

Table 10-2- Handheld Specifications

Hardware		Specification	
Battery Power	Input Battery Voltage	8 - 12 VDC	
	Power Supply	Alkaline	8 x size AA/LR6 Alkaline batteries
		NiMH	8 x size AA, Panasonic, Type BK200AAB, 1.2Vdc, 1900mAh
		The use of NiMH Rechargeable Batteries is only CE certified per IEC 62133 for FlowTracker2 part number FT2-HH-2 and above.	
		Only this type of NiMH rechargeable batteries with IEC 62133 approvals can be used, or else safety protection will be void.	
	Battery Life	8 x size AA	15 hours continuous use, typical settings*
*Defined as power on with screen on at 100% brightness, ADV sensor pinging 50% of the time, GPS off, and no sleep periods. Actual battery life will vary depending on FT2 settings, manner of use and brand of battery.			
Power Consumption		1 W (Average)	
Direct Power (ADV Lab Probe only)	Power Supply	POWER SUPPLY ASSY, 12V, 20W, 1.67A	
Coin cell	Type	<i>Coin Cell type is ML2020 Manganese Lithium</i>	
GPS	Horizontal Position Accuracy	<2.5m (8.2ft)	
	Frequency	L1 (1.575 MHz), SBAS compensation (WAAS, EGNOS, MSAS, GAGAN)	
LCD	Resolution	320 X 240 TFT Trans missive	
	LED Backlight Luminance	450 cd / m2	
Probe Interface	Battery Power to Probe	8 - 12 VDC	
	Direct Power to Probe	12 VDC	
	Data Transfer	RS-232	
	Data Storage	16 GB. Up to 10k discharge measurements. Up to 10 million velocity samples	
Physical Specifications	Waterproof Rating	IP-67 (1m submersible)	
	Handheld Dimensions	(L)10.4cm (4.1in); (W) 6.4cm (2.5in); (H) 23.7cm (9.3in)	
	Weight in Air	0.75kg (1.65lbs)	
	Weight in Water	-0.25kg (-0.55lbs)	
Operating Altitude	Maximum operating altitude is 2000m		

Hardware		Specification	
Temperature	Operating	Alkaline	-20° to 45°C (-4°F to 113°F)
		NiMH	-20° to 50°C (-4°F to 122°F)
	Storage	-30° to 70°C (-22°F to 158°F)	
		Remove batteries from FlowTracker2 handheld if storage temperatures exceed the operating temperature of Alkaline and NiMH batteries as stipulated above.	
Bluetooth	Class	Class 2, Range = 10m (32.8ft) nominal	
	FCC	Intentional radiator (FCC Part 15.247 Subpart C; ANSI C-63.4-2003 RSS-210 and ISSUE No. :8 Date :2010) <ul style="list-style-type: none"> a. FCC IDENTIFIER: S7AIW03 b. Labeling requirements (FCC ID on product & text in manual) c. Drop in, use as intended from OEM – use OEM’s FCC ID (eg, FlowTracker 2 Bluetooth) d. Modify use or signal/output – Analytics Site applies for FCC ID <ul style="list-style-type: none"> • Takes 3-4 weeks through Nemko e. Operate at specific frequency w/o interference <ul style="list-style-type: none"> • Will require FCC license to operate 	
USB	Micro USB, IP-67		

10.3. Cables and Connectors

The FlowTracker2 cable and connector specifications are listed in [Table 10:3](#),

Table 10-3- Cable and Connector Specifications

Hardware	Specification
Connector type	MCIL-8-MP wet-mate able
Standard length	1.500m (4.92ft)
Extension cable lengths	1.500m (4.920ft), 3.500m (11.5ft), 8.500m (27.9ft)
Maximum operating length	10m (32.8ft)

10.4. Certifications

The FlowTracker2 and all related hardware components comply with the following certification.

- For P/N FT2-HH-1

- CE (per IEC/EN 61010-1:2010 3rd ed, EMC directive 2004/108/EC EN61326-1) for AA Alkaline batteries, FCC, IP-67
- For P/N FT2-HH-2
 - CE (per IEC/EN 61010-1:2010 3rd ed, EMC directive 2004/108/EC EN61326-1) for AA Alkaline batteries, FCC, IP-67
 - CE (per IEC/EN 61010-1:2010 3rd ed, EMC directive 2004/108/EC EN61326-1) for NiMH rechargeable batteries that are certified to IEC 62133*, FCC, IP-67

For further questions on certification standards, contact support@sontek.com. Approved batteries are discussed further in [Section 4.3.1](#).

10.5. PC System Requirements

The PC System Requirements for operating FlowTracker2 desktop software are summarized under the following criteria,

- Microsoft Windows 7 or newer
- 1GHz processor or better (2 GHz recommended)
- 2GB memory (4GB recommended)
- 500 MB available disk space (1GB recommended)
- Monitor capable of 1024x768 resolution, or better

Section 11. Operational Considerations

The procedures outlined for operating of the FlowTracker2 instrument and the maintenance requirements should be followed to ensure that the instrumentation is in a working condition.



The user should follow operating instructions as outlined in this manual, failure to do so can void manufacturer's warranty.

11.1. Software Upgrade

The FlowTracker2 handheld and ADV are operating on unique software and firmware respectively developed specifically for the FlowTracker2 instrument. Periodic updates will be supplied by SonTek to users that are normally associated with either improvement on existing or new features. The periodic update will consist of FlowTracker2 installation file that includes the Desktop Software, Handheld Software and ADV Firmware files.

The FlowTracker2 installation file will be available from the SonTek website (<http://www.sontek.com>) or by contacting SonTek Technical Support.

11.1.1 Upgrading Handheld Software

The upgrading of handheld software and or ADV firmware is performed by uploading a single firmware file with .ft_firmware extension onto the handheld from the FlowTracker2 desktop software. The handheld upgrade is a three-step process, firstly activate handheld communication function, secondly connect desktop software with handheld using either bluetooth or USB and lastly upgrade the handheld.

Step 1 - Handheld

Activate **Communication** function on handheld to allow the user to connect to FlowTracker2 desktop software using either bluetooth or USB.

- a) *To select communication function,*
 - i). Use the up or down arrow key to scroll through the functions,
 - ii). Press the enter key to activate the communication function.

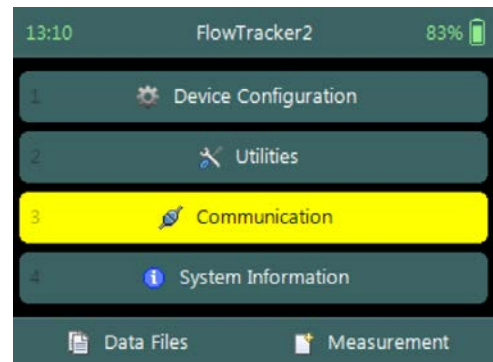

Figure 11:1 - Communication Function

The communication window displays the following instructions to enable connection between the handheld and FlowTracker2 desktop software,

- a) Open FlowTracker2 desktop software,
- b) Select “Device” menu option,
- c) Is USB cable connected or Bluetooth enabled,
- d) Select communication medium.
- e) To **CLOSE** the communication function,
 - i). Press the Left Soft Key.

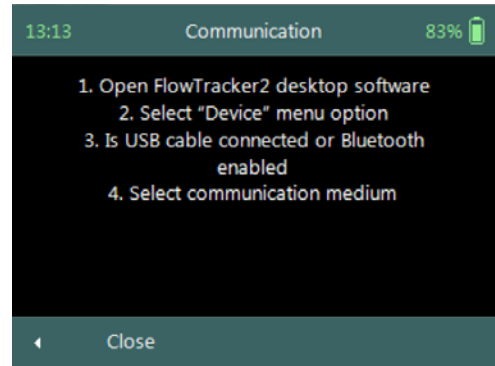

Figure 11:2 - Communication Window

Step2 – Desktop Software

Connect FlowTracker2 desktop software with handheld using either USB or Bluetooth communication.

- a) **Connect to FlowTracker2 handheld Device**,
 - i). Select “Device” menu option on main menu banner,
 - ii). Connection window will appear on software window with USB and Bluetooth communication options.
- b) **Select communication medium**,
 - i). USB - Make sure USB cable is connected before USB option is selected,
 - ii). Bluetooth – Select handheld serial number from dropdown list and select the “Connect” function.

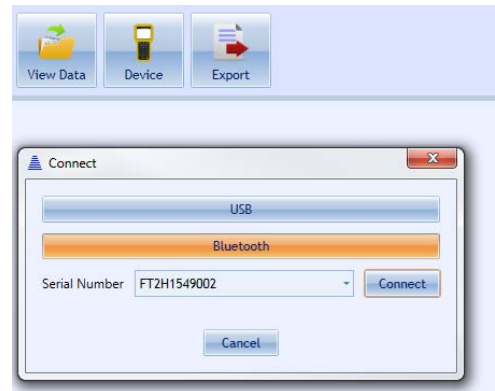

Figure 11:3 - Device Communication Window



If the handheld serial number is not listed, select the content in the box using mouse and start typing the serial number. When the serial number is entered, select “Connect” function. The desktop software will connect to the handheld using bluetooth and the serial number will be stored for future use.

Step3 – Desktop Software

Perform **Upgrade** of handheld software and or ADV firmware by selecting the upgrade function on the FlowTracker2 desktop software.

- a) **Perform Upgrade of FlowTracker2 device**,
 - i). Select “Upgrade” menu option,
 - ii). Open file window will appear with the available firmware file.
 - iii). Select the firmware file within the “Open File” window and select “Open” function.

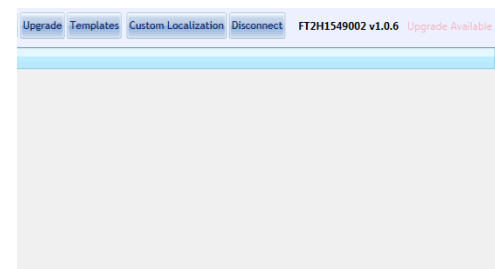

Figure 11:4 - Upgrade Function

b) *Upgrade progress Status*

- i). The FlowTracker2 desktop software gives progress status in percentage of the upgrade.

11.1.2 Upgrading ADV Firmware

The ADV firmware upgrade is performed separately from the FlowTracker2 handheld software upgrade. The user is required to either request system information or initiate data collection from the ADV to activate the firmware upgrade process.



Requesting the **Probe System Information** under [System Information \(Main Menu\)](#) on the handheld is the most efficient way of activating the ADV to initiate the ADV firmware upgrade process.

11.2. Mounting and Installation

The FlowTracker2 is commonly mounted on a top-setting wading rod. The probe and handheld mounting have been designed with wading rod use in mind, but the design is flexible enough to allow a variety of mounting arrangements. Top-setting wading rods are available from SonTek.

11.2.1 FlowTracker2 Handheld

The handheld should be secured during operation and it is recommended that the handheld is mounted to the wading rod during measurements. If the FlowTracker2 is not in use, the handheld should be stored in the carry case supplied.



The protective yellow jacket that is supplied with the FlowTracker2 handheld should stay on during operation. The jacket supply protection to the handheld casing, battery cap, USB port and LCD screen.

11.2.2 Handheld Mounting Bracket

Top Setting Rod mounting bracket to connect the handheld to the top of top setting wading rod.

- a) A mounting bracket compatible with the mounting pin on a top-setting wading rod is available from SonTek.
- b) The handheld includes one threaded insert on the back, which secures the SonTek-supplied mounting brackets.
- c) The handheld mounting simplifies the measurement process and allow the user to focus on the measurement and orientation of the probe.



Figure 11:5 - Top Setting Rod

Handheld Mounting

Universal Rod mounting bracket to connect the handheld to the universal wading rod.

- d) A mounting bracket compatible with a 20mm universal-style wading rod is available from SonTek.
- e) Neck/shoulder strap for the handheld which fits the threaded insert is available from SonTek.



Figure 11:6 - Universal Rod Handheld Mounting



The threaded insert can also be used to secure a user-supplied mounting bracket. The size of the threaded insert is $\frac{1}{4}$ -20. User-supplied mounting brackets should avoid direct contact with the keypad and screen.

11.2.3 Probe Mounting Bracket

Top Setting Rod J-Bracket to connect the 2D or 2D/3D Flowtraker2 probe to the top setting wading rod.

- a) The J-Bracket is available for mounting the probe from a top-setting wading rod. Both the bracket and complete wading rods are available from SonTek.
- b) The J-Bracket offsets the probe to one side of the wading rod, placing the sampling volume closer to the wading rod, approximately 5 cm (2 in) to one side.
- c) The bracket allows the wading rod to be used in its standard “forward” orientation.



Figure 11:7 - Top Setting Rod J-Bracket

Universal Rod J-Bracket to connect the 2D or 2D/3D Flowtraker2 probe to the universal wading rod.

- d) A J-Bracket compatible with a 20mm universal-style wading rod is available from SonTek.



Figure 11:8 – Universal Rod J-Bracket

11.3. Routine Maintenance

11.3.1 Battery Power Supply

Batteries should be checked on a routine basis and it is recommend that the following tasks are performed during routine maintenance and or completion of measurement exercise,

- a) The battery voltage level should be verified by using the battery raw data graphics displayed in [Battery Indicator](#).



Batteries should not be left in the FlowTracker2 handheld for prolonged periods as damage can occur to the handheld if the batteries are leaking. It is recommended that batteries are removed from the handheld if the instrument is not used.

- b) The use-by date should be recorded and referenced during routine maintenance and it is recommended that expired batteries should not be used in FlowTracker2.



Battery manufacturer guidelines must be followed during normal use, long term storage and charging requirements. The disposal of batteries must be done with care and it is recommended that local authority guidelines be used.

11.3.2 Cleaning Instrument

11.3.2.1 Handheld

The handheld will require some cleaning after use as the accumulation of dirt on the handheld can damage the component such as the LCD screen, USB port, probe cable connector and keypad. It is recommended that a cloth is used to wipe the handheld or soft brush.

In the case where the handheld was submerged under water or where it is covered in mud and need to be rinsed, the following guidelines should be followed,

- a) Do not remove the probe cable or battery cap while the handheld is under water or drenched.
- b) Use a dry cloth and remove excess moisture on the outside of the handheld.
- c) Remove the “yellow Jacket” from the handheld casing and apply a dry cloth to the handheld casing.
- d) Remove the probe cable and inspect if the connector pins are dry. This can indicate if there was water ingress into the connector.
- e) Remove the battery cap and battery cartridge. Inspect both the battery cap and cartridge for moisture as this can indicate water ingress.
- f) Remove batteries from battery cartridge and inspect for moisture.
- g) Place handheld, battery cartridge, batteries and yellow jacket on a dry place (not in direct sunlight) and allow to dry.



If water ingress was identified during inspection in the battery compartment or probe cable connector contact SonTek. It is not recommended to use the instrument if there is moisture in the battery compartment.

11.3.2.2 Transducers

Biological growth on the transducers does not affect velocity measurements, but can decrease acoustic signal strength and potentially increase noise in velocity data in clear water.

- a) Periodic cleaning of the FlowTracker2 transducers may be needed to maintain optimal performance in areas of high biological activity,
- b) FlowTracker2 transducers are encapsulated in an epoxy that is impervious to damage from barnacles or other types of growth,
- c) To remove growth, simply clean with a cloth or stiff (non-metallic) brush. The transducer epoxy is very durable and cannot be easily damaged except by direct impact.

11.3.3 Cable Maintenance

The FlowTracker2 probe cable is often the most vulnerable part of the system.

- a) The cable uses a durable polyurethane jacket that provides excellent long-term wear and abrasion resistance,
- b) Any cable is susceptible to damage and reasonable precautions should be taken,
- c) Inspect the cable and all connectors on a regular basis,
- d) This cable is highly noise-sensitive and should not be modified by the user.

11.3.4 O-rings

The FlowTracker2 handheld makes use of two O-ring seals and it is important that the following guidelines are followed.

11.3.4.1 Housing

- a) The handheld is designed to withstand temporary submersion, but is not intended for underwater operation.
- b) We do not recommend opening the handheld housing without specific instructions from SonTek.

11.3.4.2 Battery Cap

- a) The O-ring located on the battery cap prevents moisture entering the battery compartment.
- b) Inspection of the O-ring should be during [Hardware Inspection](#) for any cracks or defects that may exist on the O-ring.
- c) The batter cap, O-ring and battery compartment must be inspected for any moisture, dirt or material that can damage the O-ring, battery or battery connectors.

11.3.5 Condensation in FlowTracker2 Housing

Moisture in the air can potentially damage FlowTracker2 electronics if allowed to condense inside the handheld housing.

- a) The handheld is shipped with a desiccant pack inside to absorb moisture,
- b) We do not recommend opening the handheld housing without specific instructions from SonTek. If the housing has not been opened, the desiccant should not need to be replaced.

11.3.6 Zinc Anodes for Corrosion Protection

When using the FlowTracker2 in salt water, additional precautions must be taken to prevent corrosion.

- a) A sacrificial zinc anode should be installed on the probe (attached to the metal portion of the probe stem),
- b) Anode condition should be inspected regularly, and the anode should be replaced when necessary. Zinc anodes are available from SonTek,
- c) To check anode condition, try to chip away part of the anode with a screwdriver. If large portions of the anode easily fall away, the anode should be replaced,
- d) The probe and cable should be thoroughly rinsed with fresh water after each use.

11.4. Seeding

11.4.1 Scattering Material

If FlowTracker2 velocity data appears “noisy”, the most common cause is a lack of scattering material in the water.

- a) Acoustic Doppler Velocimeters require scattering material for velocity measurements (see [Principle of Operations](#)),
- b) A lack of scattering material can increase noise in velocity data. If insufficient scattering material is present, the FlowTracker2 will not be able to accurately measure velocity,
- c) In most field applications, there is sufficient scattering material naturally present,
- d) Large, quiet laboratory tanks often have insufficient natural scattering material,
- e) To evaluate seeding requirements, use the raw data display from the handheld interface,
 - i). For ideal operating conditions, the SNR should be above 10 dB,
 - ii). The FlowTracker2 can operate reliably with SNR as low as 3-4 dB.
- f) A lack of scattering material can be remedied by adding seeding.

11.4.2 Field Applications

For field applications, seeding can be introduced by stirring the bottom (e.g., walking across the river upstream of the measurement location). In some situations, seeding material will need to be introduced. An ideal seeding material should have the following qualities.

- Neutrally buoyant (to remain in suspension for a long period),
- Mean particle diameter of 10-20 μm (for peak sensitivity of the acoustic signal),
- Inexpensive, readily available, with no adverse effects on the operating environment.

The best seeding material we have found (from an acoustics point of view) are hollow glass spheres with a mean diameter about 10 μm and a mean density close to that of water.

- Small quantities of this material are available from SonTek,
- Larger quantities can be purchased from the manufacturer at the address below,

Potters Industries
Valley Forge PA USA
Phone: +1-610-651-4700
Internet: www.pottersbeads.com
Part name: Potters Spherichel

For most applications, a more practical seeding material is lime or pulverized limestone (the chalk commonly used on athletic fields).

- Large bags are inexpensive and readily available from most hardware stores,
- While not perfect, the acoustic performance is sufficient for most applications,
- A variety of distribution arrangements can be arranged to seed even very large tanks,
- A note of caution: repeated addition will gradually increase the pH in a tank (in addition to creating a layer of lime/limestone on the bottom of the tank).

11.5. Troubleshooting

This section provides suggestions for diagnosing problems with the FlowTracker2. If you have trouble finding the source of a problem, please contact SonTek.

11.5.1 Cannot Turn System On

FlowTracker power-up problems are usually related to the power supply.

- a) Check or replace the existing batteries.
- b) Verify that all batteries are correctly oriented as shown on the battery holder.
- c) Ensure the battery cap is threaded correctly and securely screwed-down.
- d) Press the On/Off power button for at least one second.
- e) Try to establish direct communication using USB cable.

11.5.2 Cannot Communicate with the FlowTracker2

If you are unable to establish external communications with the FlowTracker2 using the FlowTracker2 desktop software, the following may be helpful in identifying the cause.

11.5.2.1 Handheld

- a) Verify the power supply of the FlowTracker2 handheld by reviewing the battery indicator in the top banner or [Battery Data](#) under Utilities menu.
- b) The [Communication](#) function on the main menu must be selected.

11.5.2.2 Communication

- a) If using USB connection,
 - i). Inspect the cable and connectors for any defects,
 - ii). Verify both cable connectors between the FlowTracker2 and PC are securely connected.
 - iii). Verify the PC's USB port is functioning correctly by communicating with a different USB device.
 - iv). If the communication is still unsuccessful use a different USB cable and or PC.

-
- b) If using Bluetooth connection,
 - i). Verify the PC's Bluetooth function is turned on and enabled.
 - ii). In the FlowTracker2 software, ensure the instrument serial number is typed in correctly, in the "Connect" dialog box.
 - iii). Ensure the FlowTracker2 and PC is within nominal range of each other (10m or 32.8 ft). If possible, decrease the distance between the FlowTracker2 and PC.
 - iv). Verify the PC's Bluetooth is functioning correctly by communicating with a different Bluetooth device.
 - v). If communication is still unsuccessful use a different PC.

11.5.3 Cannot Retrieve Data from Internal Recorder

- Verify through the FlowTracker2 handheld screen that the data files are present on the recorder.
- Ensure you are waiting an adequate amount of time for the download to complete. Download times can vary with computer hardware.

11.5.4 Velocity Data Appears Noisy or Unreasonable

If the velocity data from the FlowTracker2 do not seem reasonable, the following list may help establish the cause.

- a) Lack of scattering material in the water is the most common problem (particularly in large laboratory tanks). See the FlowTracker2 Principles of Operation for details about seeding requirements.
- b) Run Beam Check as described in [Beam Check](#). This can address all aspects of FlowTracker2 operation, in particular, signal strength (scattering/seeding issues) and probe operation.
- c) Inspect the FlowTracker2 to be sure debris is not fouling the probe.
- d) Verify the FlowTracker2 mounting is stable and that instrument motion is not causing noise in the velocity data.
- e) Consider any possible environmental influences, particularly flow interference from underwater structures or obstacles.
- f) Consider the measurement environment. Highly turbulent or highly aerated water will greatly affect FlowTracker2 operation. In highly aerated water, the FlowTracker2 may not be able to operate reliably.
- g) Consider the orientation of the probe with respect to the flow direction to be sure the probe is not causing flow interference in the sampling volume.

11.5.5 Recovery Mode

The FlowTracker2 handheld software has a "recovery" feature that is used in case the software becomes non-operational. Several precautions have been taken during the

design process of the software to minimize the possibility of this occurring. The recovery mode process are described under the following steps,

- a) Power the device ON,
- b) Hold the '5' button,
- c) Recovery mode will load (you need to keep holding '5' until it loads),
- d) Recovery mode is only in English (not translated),
- e) Enabled functions:
 - i). Communication - use Desktop software to download files or upgrade handheld software and or probe firmware,
 - ii). Reset to factory defaults - will format the SD card and return to factory state (all files will be deleted, the upgraded handheld software and or probe firmware will be erased as well).

11.6. Health and Safety

Safety in the work environment is a key requirement in most organizations and this also applies to the application of FlowTracker2 instrument. The following aspects need to be considered when planning to perform discharge measurements using FlowTracker2 instrument.



It is imperative that the user follow their respective organization and or local authority guidelines in Health and Safety requirements in the work environment.

11.6.1 Planning Field Work

Planning and developing a field trip itinerary is the first step of the discharge measurement process. The following components should be included in the field trip itinerary,

- a) Contact number (mobile or satellite phone),
- b) Personnel included in field trip,
- c) Vehicle description (make, model, registration),
- d) Departure and Return date from field trip,
- e) Date of visiting measurement site and or group of sites,
- f) Measurement Site Location and or Hydrographic Site Numbers,
- g) Work to be performed at each measurement site,
- h) Contact details of accommodation (if overnight destination is required)

11.6.2 Communication

Field communication is essential for operational purposes and it improves the Health and Safety process. It is suggested that the following criteria be followed where feasible,

- a) Contact office before and after measurement is completed. Normally this is only required during flood events to inform the office that the measurements were completed and all personnel is safely off the water,
- b) Contact office at scheduled times when staying overnight, e.g., 8am and or 4pm every day. This allows the field personnel to give feedback on fieldwork and or measurements, discussing additional work that need to be performed and verify health and safety aspects,
- c) Property owners such as farmers, local authority, etc. require persons to acquire approval in advance before accessing their property. In certain cases it is also required to contact the property owner when departing and this need to be verified with the owner.

11.6.3 Measurement Site Conditions

Measurement site conditions encapsulate a number of hydraulic and physical factors that determines if it is feasible to perform a discharge measurement. The application of the FlowTracker2 instrument using the “wading” method is directly related to these conditions. The following are some aspects that need to be taken into account before a measurement is undertaken,

- a) Total water depth,
- b) Maximum water velocity,
- c) Surface waves present,
- d) Moving bed present(sediment or rocks)
- e) Debris on water surface
- f) Wild life (Alligators, Crocodiles, etc.)

If measurement site conditions are such that it is unsafe to perform a wading measurement with a FlowTracker2 instrument it is suggested that a different approach is taken in determining the discharge.

SonTek manufactures RiverSurveyor S5 and M9 instruments that are based on the Acoustic Doppler Current Profiler principle. These instruments can be used from multiple platforms such hydroboards, manned boats or remote control boats in the following discharge measurement methods,

- i). Moving Boat Measurement,

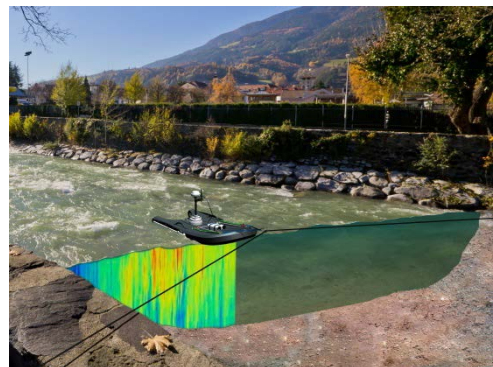

**Figure 11:9 – RiverSurveyor M9
– Moving Boat Method**

ii). Stationary Measurement.

Section 12. FlowTracker2 File Format

12.1. FlowTracker2 JSON File

The FlowTracker2 measurement file was developed on the JSON format. The handheld and desktop software uses the FlowTracker2 measurement files structure (see [Table 4:2](#)) as the primary format for the storage of system information, configuration, raw data, calculations and post processing. The measurement files with .ft extension created from the FlowTracker2 handheld can be directly imported into the FlowTracker2 desktop software for evaluation and post processing if required.

The FlowTracker2 measurement file with .ft extension is essentially a ZIP file that combines the different JSON files created during the measurement.



Changing the extension from .ft to .zip should not be performed on the original FlowTracker2 measurement file. It is recommended that if this action is required a duplicate copy of the measurement file is created. It is expected that this action is only required by advanced users to extract the data in either a database or 3rd party evaluation software.

The FlowTracker2 measurement file consists of three different file types given below. The Beam Check and Point measurement files are placed in sub folders to separate from the main Data File.

- a) Beam Check,
- b) Point Measurements
- c) Data File

20151106-150032_09522600.zip

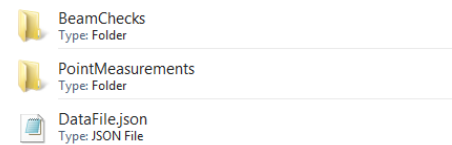

Figure 12:1 - FlowTracker2 Measurement File

JSON file is created for each Beam Check and Point Measurement performed during the FlowTracker2 measurement and stored in respective sub folders. The number of point measurement files can be significant depending on the number of point velocity measurement performed in Discharge or General Mode.



KISTERS developed an import script for the FlowTracker2 measurement file (JSON) for both Hydstra and WISKI Time Series Data Management Systems. SonTek involved KISTERS from the initial development stage of the measurement file structure to ensure that the import of FlowTracker2 data is seamless.

Further information on the JSON format can be accessed from the JSON website (www.json.org/).

12.1.1 Measurement File Framework

FlowTracker2 Measurement File Framework

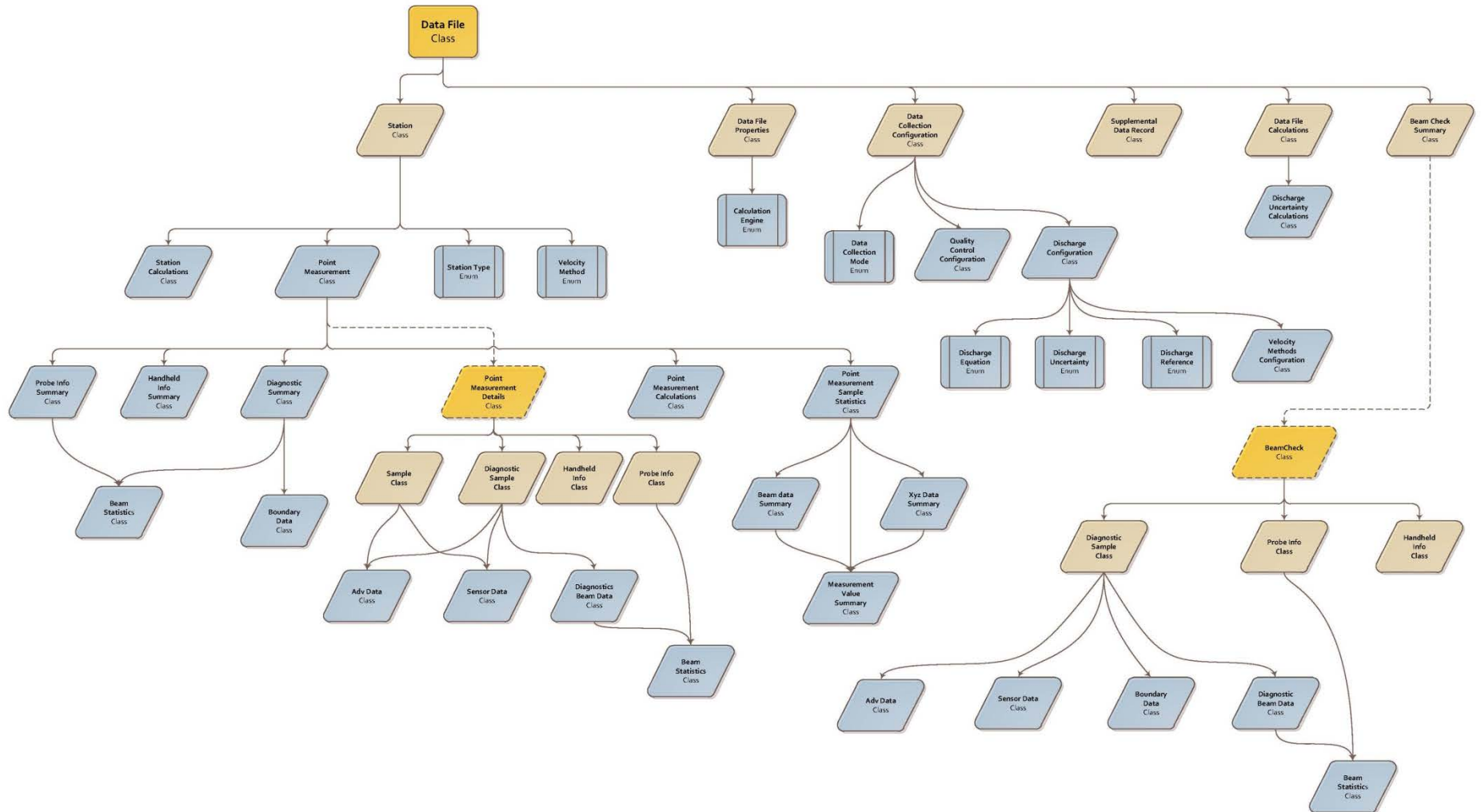

12.1.2 Measurement File Structure

DataFile						Base Type	Description	
Main Tier	1 st Tier	2 nd Tier	3 rd Tier	4 th Tier	5 th Tier			
Properties: DataFileProperties	StartTime					DateTime		
	EndTime					DateTime		
	SiteNumber					String		
	SiteName					String		
	Operator					String		
	Comment					String		
	LocalTimeUtcOffset					TimeSpan		
	CalculationsEngine					CalculationsEngine		
Configuration: DataCollectionConfiguration	DataCollectionMode					DataCollectionMode		
	AveragingTime					TimeSpan		
	SamplingRate					Double		
	Salinity					Double		
	Temperature					Double		
	SoundSpeed					Double		
	MountingCorrection					Double		
	QualityControl: QualityControlConfiguration	SnrThreshold					Double	
		StdErrorThreshold					Double	
		SpikeThreshold					Double	
		VelocityAngleForWarning					Double	
		TiltAngleForWarning					Double	
	Discharge: DischargeConfiguration (optional)	DischargeEquation					DischargeEquation	
		DischargeUncertainty					DischargeUncertainty	
		DischargeReference					DischargeReference	
		MaxStationDischargeForCaution					Double	
		MaxStationDischargeForWarning					Double	
		MaxDepthChangeForWarning					Double	
		MaxSpacingChangeForWarning					Double	
		SixTenthsMethodDepth					Double	
VelocityMethods: VelocityMethodsConfiguration	TwoTenthsSixTenthsEightTenths					Boolean		
	Kreps					Boolean		
	FivePoint					Boolean		
	SixPoint					Boolean		
	VerticalVelocityCurve					Boolean		
HandheldInfo: HandheldInfo								
Stations: List<Station>	Id					Guid		
	CreationTime					DateTime		
	Gps					GpsRecord (optional)		
	Location					Double		
	LocationY					Double (optional)		
	Depth					Double		
	Depth2					Double (optional)		

DataFile						Base Type	Description		
Main Tier	1 st Tier	2 nd Tier	3 rd Tier	4 th Tier	5 th Tier				
	StationType					StationType			
	VelocityMethod					VelocityMethod			
	ManualVelocity					Double (optional)			
	IceThickness					Double (optional)			
	WaterSurfaceToBottomOfIce					Double (optional)			
	WaterSurfaceToBottomOfSlush					Double (optional)			
	CorrectionFactor					Double			
	Comment					String			
	PointMeasurements: List<PointMeasurement>(optional)	Id					Guid		
		FractionalDepth					Double		
		DistanceFromBottom					Double		
		StartTime					DateTime		
		EndTime					DateTime		
		SampleStatistics: PointMeasurementSampleStatistics	OriginalVelocity: XyzDataSummary			X: MeasurementValueSummary	Min	Double	
							Max	Double	
							Average	Double	
							StandardDeviation	Double	
							Count	Int32	
						Y: MeasurementValueSummary	Min	Double	
							Max	Double	
							Average	Double	
							StandardDeviation	Double	
	Z: MeasurementValueSummary					Min	Double		
						Max	Double		
						Average	Double		
		StandardDeviation	Double						
	DespikedVelocity: XyzDataSummary				X: MeasurementValueSummary	Min	Double		
Max						Double			
Average						Double			
StandardDeviation						Double			
Y: MeasurementValueSummary					Min	Double			
					Max	Double			
					Average	Double			
					StandardDeviation	Double			
Z: MeasurementValueSummary					Min	Double			
					Max	Double			
					Average	Double			
					StandardDeviation	Double			
Temperature:				Min	Double				

DataFile						Base Type	Description	
Main Tier	1 st Tier	2 nd Tier	3 rd Tier	4 th Tier	5 th Tier			
			MeasurementValueSummary	Max		Double		
				Average		Double		
				StandardDeviation		Double		
				Count		Int32		
			Pressure: MeasurementValueSummary	Min		Double		
				Max		Double		
				Average		Double		
				StandardDeviation		Double		
			BatteryVoltage: MeasurementValueSummary	Count		Int32		
				Min		Double		
				Max		Double		
				Average		Double		
			Tilt: MeasurementValueSummary	StandardDeviation		Double		
				Count		Int32		
				Min		Double		
				Max		Double		
			Pressure: MeasurementValueSummary	Average		Double		
				StandardDeviation		Double		
				Count		Int32		
				Min		Double		
			ProbeDepth: MeasurementValueSummary	Max		Double		
				Average		Double		
				StandardDeviation		Double		
				Count		Int32		
			Snr: BeamDataSummary	Beam0: MeasurementValueSummary	Min		Double	
					Max		Double	
					Average		Double	
					StandardDeviation		Double	
Beam1: MeasurementValueSummary	Count			Int32				
	Min			Double				
	Max			Double				
	Average			Double				
Beam2: MeasurementValueSummary	StandardDeviation			Double				
	Count			Int32				
	Min			Double				
	Max			Double				
			Average		Double			
			StandardDeviation		Double			
			Count		Int32			

DataFile						Base Type	Description		
Main Tier	1 st Tier	2 nd Tier	3 rd Tier	4 th Tier	5 th Tier				
		Calculations: PointMeasurementCalculations	Warnings			QualityControlWarnings			
			Velocity			XyzData			
			VelocityStandardError			XyzData			
			FlowAngle			Double			
			Snr			BeamData			
			SnrStandardDeviation			BeamData			
			Samples			Int32			
			Spikes			Int32			
			Tilt			Double			
			BoundaryAvoidance			BoundaryAvoidanceStatus			
		Diagnostics: DiagnosticsSummary	Boundary: BoundaryData	BoundaryRange			Double		
				VelocityAmbiguity			Double		
				VelocityResolution			Double		
			Beams: ReadOnlyCollection<BeamStatistics>	NoiseLevel			Double		
				PeakLocation			Double		
		PeakLevel				Double			
		HandheldInfo: HandheldInfoSummary	SoftwareVersion:				String		
			WadingRod				WadingRod		
			Units				UnitType		
		ProbeInfo: ProbeInfoSummary	SerialNumber				String		
			FirmwareVersion				String		
			NumberOfBeams				Int32		
			NominalBeamStatistics: ReadOnlyCollection<BeamStatistics>	NoiseLevel				Double	
				PeakLocation				Double	
		Calculations: StationCalculations	Warnings				QualityControlWarnings		
			MeanVelocityInVertical				XyzData		
			MeanPanelVelocity				XyzData		
	Width					Double			
	Area					Double			
	Discharge					Double			
	FractionOfTotalDischarge					Double			
	Snr					BeamData			
	Temperature					Double			
VelocityAngle					Double				
BoundaryAvoidance					BoundaryAvoidanceStatus				
Samples					Int32				
Spikes					Int32				
Tilt					Double				
VelocityStandardError					XyzData				
SupplementalDataRecord: List<SupplementalDataRecord	Time				DateTime				
	GaugeHeight				Double				

DataFile						Base Type	Description	
Main Tier	1 st Tier	2 nd Tier	3 rd Tier	4 th Tier	5 th Tier			
> (optional)	RatedDischarge					Double		
	Temperature					Double		
	Salinity					Double		
	Comment					String		
Calculations: DataFileCalculations	Warnings					QualityControlWarnings		
	Area					Double		
	Discharge					Double		
	Width					Double		
	Velocity					XyzData		
	VelocityStandardError					XyzData		
	Depth					Double		
	Snr					Double		
	Temperature					Double		
	RatedDischarge					Double		
	GaugeHeight					Double		
	UncertaintyIso: DischargeUncertaintyCalculations	Accuracy					Double	
		Depth					Double	
		Velocity					Double	
		Width					Double	
		Method					Double	
		NumberOfStations					Double	
	UncertaintyIve: DischargeUncertaintyCalculations	Overall					Double	
		Accuracy					Double	
		Depth					Double	
Velocity						Double		
Width						Double		
Method						Double		
BeamChecks: List<BeamCheckSummary>	NumberOfStations					Double		
	Overall					Double		
	Id					Guid		
	Time					DateTime		
AirPressureMeasurements:List <PressureReading>	NumberofSamples					Int32		
	AutoQualityControlWarnings					QualityControlWarnings		
AirPressureMeasurements:List <PressureReading>	Time					DateTime		
	Pressure					Double		

Point Measurement Details					Base Type	Description	
Main Tier	1 st Tier	2 nd Tier	3 rd Tier	4 th Tier			
Id					Guid		
SamplingRate					Double		
Samples: ReadOnlyCollection<Sample>	Time				DateTime		
	Adv: AdvData	Velocity			XyzData		
		Snr				Double	
	Sensors: SensorData	Temperature				Double	
		SoundSpeed				Double	
		Pressure				Double	
		Voltage				Double	
Accelerometer				XyzData			
Diagnostics: DiagnosticsSample	Time				DateTime		
	Adv: AdvData	Velocity			XyzData		
		Snr				Double	
	Sensors: SensorData	Temperature				Double	
		SoundSpeed				Double	
		Pressure				Double	
		Voltage				Double	
	Accelerometer				XyzData		
	Boundary				BoundaryData		
	ProfileRange: ReadOnlyCollection				Double		
	Beams: ReadOnlyCollection<DiagnosticsBeamData>	Statistics: BeamStatistics	NoiseLevel			Double	
PeakPosition					Double		
PeakLevel					Double		
Profile: ReadOnlyCollection				Double			
DataCollectionConfiguration: DataCollectionConfiguration (optional)							
HandheldInfo: HandheldInfo	SerialNumber				String		
	SoftwareVersion				String		
	BoardsInfo				String		
	CpuSerialNumber				String		
	OperatingSystem				String		
	Settings				Object (optional)		
ProbeInfo: ProbeInfo	InstrumentType				String		
	SerialNumber				String		
	FirmwareVersion				String		
	NumberOfBeams				Int32		
	IsPressureSensorPresent				Boolean		
	PressureSensorLocation				XyzData		
	ProbeBottomZ				Double		
	NominalBeamStatistics: ReadOnlyCollection<BeamStatistics>	NoiseLevel				Double	
		PeakPosition				Double	
PeakLevel					Double		
RawConfiguration				Object (optional)			
Spikes: ReadOnlyCollection					Int32		
AirPressure					Double		
SiteLocation: GpsRecord					Object (optional)		

Point Measurement Details					Base Type	Description
Main Tier	1st Tier	2nd Tier	3rd Tier	4th Tier		
ProbeDepths: ReadOnlyCollection					Double	

Beam Check					Base Type	Description	
Main Tier	1 st Tier	2 nd Tier	3 rd Tier	4 th Tier			
Id					Guid		
HandheldInfo: HandheldInfo	SerialNumber				String		
	SoftwareVersion				String		
	BoardsInfo				String		
	CpuSerialNumber				String		
	OperatingSystem				String		
	Settings				Object (optional)		
ProbeInfo: ProbeInfo	InstrumentType				String		
	SerialNumber				String		
	FirmwareVersion				String		
	NumberOfBeams				Int32		
	NominalBeamStatistics: ReadOnlyCollection<BeamStatistics>	NoiseLevel				Double	
		PeakPosition				Double	
		PeakLevel				Double	
RawConfiguration				Object (optional)			
Samples: ReadOnlyCollection<DiagnosticSample>	Time				DateTime		
	Adv: AdvData	Velocity				XYZData	
		Snr				Double	
	Sensors: SensorData	Temperature				Double	
		SoundSpeed				Double	
		Pressure				Double	
		Voltage				Double	
		Accelerometer				XYZData	
	Boundary: BoundaryData	BoundaryRange				Double	
		VelocityAmbiguity				Double	
		MaxPingPrecision				Double	
	ProfileRange: ReadOnlyCollection				Double		
	Beams: ReadOnlyCollection<DiagnosticsBeamData>	Statistics: BeamStatistics	NoiseLevel			Double	
			PeakPosition			Double	
PeakLevel					Double		
Profile: ReadOnlyCollection					Double		
AutoQualityControlWarnings					QualityControlWarnings		

XYZData					Base Type	Description
Main Tier	1st Tier	2nd Tier	3rd Tier	4th Tier		
X					Double	
Y					Double	
Z					Double	

BeamData					Base Type	Description
Main Tier	1st Tier	2nd Tier	3rd Tier	4th Tier		
Beam0					Double	
Beam1					Double	
Beam2					Double	

GpsRecord					Base Type	Description
Main Tier	1st Tier	2nd Tier	3rd Tier	4th Tier		
DeviceTime					DateTime	
SatelliteTime					TimeSpan	
Latitude					Double	
Longitude					Double	
FixQuality					Int32	
NumberOfSatellites					Int32	
Hdop					Double	
Altitude					Double	
GeoidalSeparation					Double	

12.2. FlowTracker2 CSV Output

Comma Separated Values (CSV) file format is a basic output designed for easy access and interpretation of the data with the most common variables of FlowTracker2 incorporated.



The variables included in the CSV format are similar to Original FlowTracker2 ASCII exports and existing users will be familiar with the layout and content.

12.2.1 CSV File Structure

The **Comma Separated Values** files created during the export process consists of four CSV files, defined by unique file name that summarizes the content of the file as described in [Table 12:1](#).

Table 12-1 - CSV File Types

File	Name	Description	Data Layout
ctl	Control	System configuration data	Rows
dat	Raw Data	Raw, one-second velocity and SNR data	Columns
dis	Discharge	Final data results in a self-explanatory form that is easy to integrate with database utilities	Rows, Columns
sum	Summary	Velocity and quality control data from all measurements	Columns

The layout of the data in each of the CSV files is organized based on Rows, Columns or a combination of both. The data descriptions for the Row or Column layout are defined in [Table 12:2](#).



The Desktop Software Build Version is written in the first row of each CSV file independent if the file layout is based on Row or Columns. The units included for each variable in the CSV files are separated from the file name and data.

Table 12-2 - CSV Row and Column

Type	Number	Description
Row \ Column	1 st	Row contain Desktop Software Build version
Column	2 nd	Row contain the variable \ parameter name
	3 rd	Row contain the units
	4 th	Row contain the first data line
Row	2 nd	Column contain variable \ parameter name
	3 rd	Column contain the units
	4 th	Column contain X component or Beam 1
	5 th	Column contain Y component or Beam 2

12.2.2 CSV Variables

The **Variables** that are exported in each of the Comma Separated Values files are defined in the following tables with the variable name, description and applicability to either the Discharge or General Modes.

The **Control** file consists of all the system information for both the handheld and probe and the quality control parameter settings based on either default or user configuration. The variables exported in the control file are given in [Table 12:3](#).

Table 12-3 - Control File Variables

Variable	Mode	Description
Desktop_Software_Build_Version	D, G	Version of desktop software
Number_Of_Stations	D, G	Station number
Start_Time	D, G	Start time of measurement
End_Time	D, G	End time of measurement
Local_Time_UTC_Offset_Hours	D, G	Local time offset for UTC in hours
Handheld_Serial_Number	D, G	Handheld serial number
Handheld_CPU_Serial_Number	D, G	Handheld CPU serial number
Handheld_Boards_Info	D, G	Handheld boards info
Handheld_Software_Version	D, G	Handheld software version
Handheld_Operating_System	D, G	Handheld operating system
Wading_Rod	D	Type of wading rod
ADV_System_Frequency	D, G	ADV system frequency
ADV_Serial_Number	D, G	ADV serial number
ADV_Firmware_Version	D, G	ADV firmware version
ADV_Number_Of_Beams	D, G	ADV number of beams
ADV_Noise_Level	D, G	ADV noise level
ADV_Peak_Position	D, G	ADV peak position
ADV_Peak_Level	D, G	ADV peak level
Configuration_Data_Collection_Mode	D, G	Data collection mode
Configuration_Averaging_Time	D, G	Averaging time
Configuration_Sampling_Rate	D, G	Sampling rate
Configuration_Salinity	D, G	Salinity measured using external sensor
Configuration_Temperature	D, G	Temperature internal or external measured
Configuration_Sound_Speed	D, G	Sound Speed calculated or external measured
Configuration_Mounting_Correction	D, G	Mounting Correction in percentage
Configuration_Quality_Control_SNR_Threshold	D, G	SNR Threshold for quality control process
Configuration_Quality_Control_Std_Error_Threshold	D, G	Std Error Threshold for quality control process
Configuration_Quality_Control_Spike_Threshold	D, G	Spike Threshold for quality control process
Configuration_Quality_Control_Velocity_Angle_For_Warning	D, G	Velocity Angle for quality control process
Configuration_Quality_Control_Tilt_Angle_For_Warning	D, G	Tilt Angle for quality control process

Variable	Mode	Description
Configuration_Discharge_Equation	D	Discharge equation used for discharge calculation in measurement section
Configuration_Discharge_Reference	D	Specify type of external discharge used to reference discharge measurement
Configuration_Discharge_Quality_Control_Max_Station_Discharge_For_Warning	D	Max station discharge for quality control process
Configuration_Discharge_Quality_Control_Max_Depth_Change_For_Warning	D	Max depth change for quality control process
Configuration_Discharge_Quality_Control_Max_Spacing_Change_For_Warning	D	Max spacing change for quality control process
Configuration_Discharge_Velocity_Methods	D	Discharge velocity methods used in determining mean velocity

The **Raw Data** file consists of the one second velocity, SNR and acceleration data with date and time stamp. The variables exported in the raw data file are given in [Table 12:4](#).

Table 12-4 - Raw Data File Variables

Variable	Mode	Description
#	D, G	Burst or measurements number
Year	D, G	Year
Month	D, G	Month
Day	D, G	Day
Hour	D, G	Hour
Minute	D, G	Minute
Second	D, G	Second
VelX	D, G	Raw 1 second X velocity
VelY	D, G	Raw 1 second Y velocity
VelZ	D, G	Raw 1 second Z velocity
SNR1	D, G	Signal-to-Noise Ratio beam 1
SNR2	D, G	Signal-to-Noise Ratio beam 2
SNR3	D, G	Signal-to-Noise Ratio beam 3
AccX	D, G	Raw 1 second X acceleration
AccY	D, G	Raw 1 second Y acceleration
AccZ	D, G	Raw 1 second Z acceleration

The **Discharge** file consists of system information, site details, quality control checks, Beam Checks, uncertainty calculations, supplemental data and all station data related to discharge measurement. The variables exported in the discharge file are given in [Table 12:5](#).

Table 12-5 - Discharge File Variables

Variable	Mode	Description
Desktop_Software_Build_Version	D, G	Version of desktop software
Site_Name	D, G	Name of measurement site

Variable	Mode	Description
Site_Number	D, G	Number of measurement site
Local_Start_Time	D, G	Local start time of measurement
Local_End_Time	D, G	Local end time of measurement
Local_Time_UTC_Offset_Hours	D, G	Local time offset for UTC in hours
Operator	D, G	Operator
Handheld_Serial_Number	D, G	Serial number of handheld
Handheld_Software_Version	D, G	Software version of handheld
Wading_Rod	D	Type of wading rod
Handheld_Units_System	D, G	Metric or English
Number_Of_Probes	D, G	Number of ADV used during measurement. Software allows user to interchange ADV during measurement
ADV_Serial_Number	D, G	Serial number of ADV
ADV_Firmware_Version	D, G	Firmware version of ADV
ADV_Number_Of_Beams	D, G	Number of beams
Comment	D, G	Comment entry field
Calculations_Engine	D, G	Calculation engine
Number_Of_Stations	D, G	Number of stations in a measurement
Discharge_Equation	D	Discharge equation used for calculation
Rated_Discharge	D	Rated flow based on measuring site stage discharge relationship
Rated_Height	D	Gauge Height taken for water level reference
Minimum_Boundary_Status	D, G	Undefined or lowest of boundary conditions found
Total_Width	D	Total width of measurement section
Total_Area	D	Total area of measurement section
Total_Discharge	D	Total discharge of measurement
Mean_Depth	D, G	Average depth of the section
Mean_Velocity_Vx	D	The area-weighted panel velocity averaged over the entire section for X velocity
	G	Mean Vx is the mean of the X velocity of all point velocity measurements.
Mean_Velocity_Vy	D	The area-weighted panel velocity averaged over the entire section for Y velocity
	G	Mean Vy is the mean of the Y velocity of all point velocity measurements.
Mean_Velocity_Vz	D	The area-weighted panel velocity averaged over the entire section for Z velocity
	G	Mean Vz is the mean of the Z velocity of all point velocity measurements.
Mean_SNR	D, G	Mean SNR of all point velocity measurements
Mean_VxErr	D	Mean Vx Standard Error of each station X velocity standard error.
	G	Mean Vx Standard Error is the mean of the X velocity standard error of all point velocity measurements.
Mean_VyErr	D	Mean Vy Standard Error of each station Y velocity

Variable	Mode	Description
		standard error.
	G	Mean Vy Standard Error is the mean of the Y velocity standard error of all point velocity measurements.
Mean_VzErr	D	Mean Vz Standard Error of each station Z velocity standard error.
	G	Mean Vz Standard Error is the mean of the Z velocity standard error of all point velocity measurements.
Mean_Temp	D	Mean Temperature is the mean of all the station temperature measurements
	G	Mean Temperature of all point temperature measurements
Quality_Control_Checks	D, G	Quality_Control_Checks
Station_Spacing	D	Spacing between stations has changed by more than Max Location Change %.
Station_Order	D	Station location out of sequence or outside river edge.
Water_Depth	D, G	Station depth differs from adjacent stations by more than Max Depth Change %.
Boundary_Interference	D, G	Evaluates the measurement environment for interference from underwater obstacles
Fractional_Depth	D	Verify ratio between measurement depth and total depth and this should not >1
Low_SNR	D, G	Warning if SNR below 4dB
Approaching_Low_SNR	D, G	Warning if SNR between 4dB and 7 dB
Beam_SNRs_Not_Similar	D, G	Difference in SNR for any 2 beams is > SNR Threshold
Large_SNR_Variation	D, G	One-second SNR data varies more than expected during a measurement along a single beam.
SNR_Threshold_Variation	D	SNR more than SNR Threshold different previous measurements
Velocity_Standard_Error	D, G	σ_V (standard error of velocity) is a direct measure of the accuracy of velocity data.
Percent_Of_Spikes	D, G	The percentage of spikes within a point velocity measurement.
Velocity_Angle	D, G	The flow angle towards the ADV.
Rod_Angle	D, G	The angle of the wading rod from the vertical
Station_Discharge	D	Station contains a large portion of the total discharge.
End_Edge_Location	D	Station location out of sequence or outside river edge.
Noise_Level	D, G	Shows the electronics noise level for the receiver of each beam
Peak_Location	D, G	The physical location of the sampling volume
Peak_Shape	D, G	The shape of the sampling volume
Pre_Calculation_Validation	D, G	Consistency check on station data (e.g. edges, island edges, etc.)

Variable	Mode	Description
Discharge_Uncertainty_ISO	D	Discharge_Uncertainty_ISO
Overall	D	Overall
Accuracy	D	Accuracy
Depth	D	Depth
Velocity	D	Velocity
Width	D	Width
Method	D	Method
#_Stations	D	Number of Stations
Discharge_Uncertainty_IVE	D	Discharge_Uncertainty_IVE
Overall	D	Overall
Accuracy	D	Accuracy
Depth	D	Depth
Velocity	D	Velocity
Width	D	Width
Supplemental_Data	D	Supplemental_Data
Record_Number	D	Sequence number assigned to each data entry
Date_And_Time	D, G	Date and time when the supplement data was recorded.
Gauge_Height (m)	D, G	Gauge height reading
Rated_Discharge (m ³ /s)	D, G	Rated flow based on stage discharge relationship
Comments	D, G	Comments regarding supplement data
Automated_BeamCheck	D, G	Automated_BeamCheck
Record_Number	D, G	Sequence number assigned to each automated beam check.
Date_And_Time	D, G	Date and time of automated beam check.
Noise_Level_Check	D, G	Measured electronics noise level is compared to reference data.
SNR_Check	D, G	The SNR is checked as sufficient for reliable data collection
Peak_Location_Check	D, G	The physical location of the sampling volume is compared to the expected location
Peak_Shape_Check	D, G	The shape of the sampling volume curve is compared to the expected shape.
Station Data	D, G	Station Data
St	D, G	Station number
Clock	D, G	Measurement time from FlowTracker2 clock
GPSLat	D, G	GPS Latitude
GPSLon	D, G	GPS Longitude
Loc	D, G	Station location
LocY	D, G	Station location Y
FinalD	D, G	Mid and Mean Section methods, same as Depth. Japanese method, average of Depth and Depth2
IceD	D, G	Ice thickness
WsIceD	D, G	Water surface to bottom of ice
WsSlushD	D, G	Water surface to bottom of slush

Variable	Mode	Description
%Dep	D, G	Measurement depth location, as fraction of the effective depth
MeasD	D, G	Point measurement depth, measured from the water surface
Npts	D, G	Number of samples in measurement; one sample collected per second
Spike	D, G	Number of spikes removed before calculating mean values
VelX	D, G	Mean X velocity component of point velocity measurement
VelY	D, G	Mean Y velocity component of point velocity measurement
VelZ	D, G	Mean Z velocity component of point velocity measurement
Angle	D, G	Velocity angle calculated as $\text{atan}(V_y/V_x)$
VxErr	D, G	Standard error of X velocity
VyErr	D, G	Standard error of Y velocity
VzErr	D, G	Standard error of Z velocity
SNR1	D, G	Signal-to-Noise Ratio beam 1
SNR2	D, G	Signal-to-Noise Ratio beam 2
SNR3	D, G	Signal-to-Noise Ratio beam 3
Bnd	D, G	Boundary QC measurement
Temp	D, G	Water temperature
CorrFact	D, G	Correction factor used to scale mean station velocity
Tilt	D, G	Mean wading rod angle during point velocity measurement
MeanV	D	Mean panel velocity based on panel discharge and area.
	G	Mean V is the mean of the X velocity of all point velocity measurements.
Area	D	Station area
Flow	D	Station discharge
%Q	D	Percent of total discharge

The **Summary** file consists of the velocity method, velocity, SNR and standard error data of each point velocity measurement. The variables exported in the summary file are given in [Table 12-6](#).

Table 12-6 - Summary File Variables

Variable	Mode	Description
Desktop_Software_Build_Version	D, G	Version of desktop software
#	D, G	Burst or measurements number

Variable	Mode	Description
St	D, G	Station Number
Method	D, G	Discharge Measurement Method
%Dep	D, G	Measurement depth location, as fraction of the effective depth
MeasD	D, G	Point measurement depth, measured from the water surface
Npts	D, G	Number of samples in measurement; one sample collected per second
Spike	D, G	Number of spikes removed before calculating mean values
CorrFact	D, G	Correction factor used to scale mean station velocity
Loc	D, G	Station location
LocY	D, G	Station location Y
Depth1	D, G	Total Water Depth1
Depth2	D, G	Total Water Depth2
FinalD	D, G	Mid and Mean Section methods, same as Depth. Japanese method, average of Depth and Depth2
IceD	D, G	Ice thickness
WslceD	D, G	Water surface to bottom of ice
WsSlushD	D, G	Water surface to bottom of slush
VelX	D, G	Mean X velocity component of point velocity measurement
VelY	D, G	Mean Y velocity component of point velocity measurement
VelZ	D, G	Mean Z velocity component of point velocity measurement
Angle	D, G	Velocity angle calculated as $\text{atan}(V_y/V_x)$
VxErr	D, G	Standard error of X velocity
VyErr	D, G	Standard error of Y velocity
VzErr	D, G	Standard error of Z velocity
SNR1	D, G	Signal-to-Noise Ratio beam 1
SNR2	D, G	Signal-to-Noise Ratio beam 2
SNR3	D, G	Signal-to-Noise Ratio beam 3
SNRStd1	D, G	Standard Deviation of Signal-to-Noise Ratio beam 1
SNRStd2	D, G	Standard Deviation of Signal-to-Noise Ratio beam 2
SNRStd3	D, G	Standard Deviation of Signal-to-Noise Ratio beam 3
Temp	D, G	Water temperature
Batt	D, G	Battery Voltage
Tilt	D, G	Mean wading rod angle during point velocity

Variable	Mode	Description
		measurement

12.3. Original FlowTracker ASCII vs JSON

Data File			Variable	Comment
Next of Kin	Variable	Base Type		
Properties: DataFileProperties	StartTime	DateTime	DIS.StartDateAndTime	
	EndTime	DateTime	last DAT.ymdhms, or other	
	SiteNumber	String	--	
	SiteName	String	DIS.SiteName	
	Operator	String	DIS.Operators	
	Comment	String		
	LocalTimeUtcOffset	TimeSpan		
	CalculationsEngine	CalculationsEngine	CalculationsEngine FlowTracker1	
Configuration: DataCollectionConfiguration	DataCollectionMode	DataCollectionMode	CTL.KeypadMode	
	AveragingTime	TimeSpan	CTL.SamplesPerBurst	
	SamplingRate	Double	CTL.SampleInterval	
	Salinity	Double	CTL.DefaultSalinity	
	Temperature	Double	CTL.DefaultTemperature, or NaN if CTL.TemperatureMode is MEASURED	
	SoundSpeed	Double	CTL.DefaultSoundSpeed, or NaN if CTL.TemperatureMode is MEASURED	
	MountingCorrection	Double	CTL.MountingCorrection	
QualityControl: QualityControlConfiguration	SnrThreshold	Double	--	
	StdErrorThreshold	Double	--	
	SpikeThreshold	Double	--	
	VelocityAngleForWarning	Double	--	
	TiltAngleForWarning	Double	--	
Discharge: DischargeConfiguration (optional)	DischargeEquation	DischargeEquation	DIS.DischargeEquation	
	DischargeUncertainty	DischargeUncertainty	--	Not exported (not useful)
	DischargeReference	DischargeReference	DIS.Rated if any supplemental data recs, else Measured	
	MaxStationDischargeForCaution	Double		
	MaxStationDischargeForWarning	Double	--	
	MaxDepthChangeForWarning	Double	--	
	MaxSpacingChangeForWarning	Double	--	
VelocityMethods: VelocityMethodsConfiguration	TwoTenthsSixTenthsEightTenths	Boolean	--	
	Kreps	Boolean	--	
	FivePoint	Boolean	--	

Data File			Variable	Comment
Next of Kin	Variable	Base Type		
	SixPoint	Boolean	--	
	VerticalVelocityCurve	Boolean	--	
HandheldInfo: HandheldInfo			--	
Stations: List<Station>	Id	Guid	--	Not exported
	CreationTime	DateTime	DIS.StartDateAndTime plus first DIS.Clock	Exported when no point measurements at this station.
	Gps	GpsRecord (optional)	--	Only GPS lat/lon exported
	Location	Double	SUM.Loc (or DIS.Loc) (General mode: SUM.Loc1 or DIS.Loc1)	
	LocationY	Double (optional)	SUM.Loc2 or DIS.Loc2	
	Depth	Double	DIS.Depth or DIS.Depth1	Only final depth exported
	Depth2	Double (optional)	DIS.Depth2	Only final depth exported
	StationType	StationType	uses DIS.IceD, DIS.NPts, and DIS.Vel to decide	Not exported
	VelocityMethod	VelocityMethod	Guessed from DIS.FractionalDepth and DIS.Vel	
	ManualVelocity	Double (optional)	Guessed from DIS.FractionalDepth and DIS.Vel	Not exported separately but can be inferred
	IceThickness	Double (optional)	DIS.IceD	
	WaterSurfaceToBottomOfIce	Double (optional)	DIS.IceD	
	WaterSurfaceToBottomOfSlush	Double (optional)	--	
	CorrectionFactor	Double	DIS.CorrFact	
Comment	String	--	Not exported	
PointMeasurements: List<PointMeasurement>>(optional)	Id	Guid	--	Not exported
	FractionalDepth	Double	DIS.FractionalDepth	
	DistanceFromBottom	Double	DIS.MeasD	Distance from water surface exported
	StartTime	DateTime	first DAT.ymdhms	
	EndTime	DateTime	last DAT.ymdhms	Not exported
OriginalVelocity: X: MeasurementValueSummary	Min	Double	Calculated from DAT file samples	Not exported
	Max	Double	Calculated from DAT file samples	Not exported
	Average	Double	Calculated from DAT file samples	Not exported
	StandardDeviation	Double	Calculated from DAT file samples	Not exported
	Count	Int32	Calculated from DAT file samples	Not exported
OriginalVelocity: Y: MeasurementValueSummary	Min	Double	Calculated from DAT file samples	Not exported
	Max	Double	Calculated from DAT file samples	Not exported
	Average	Double	Calculated from DAT file samples	Not exported
	StandardDeviation	Double	Calculated from DAT file samples	Not exported
	Count	Int32	Calculated from DAT file samples	Not exported
OriginalVelocity: Z: MeasurementValueSummary	Min	Double	Calculated from DAT file samples	Not exported
	Max	Double	Calculated from DAT file samples	Not exported
	Average	Double	Calculated from DAT file samples	Not exported

Data File			Variable	Comment
Next of Kin	Variable	Base Type		
	StandardDeviation	Double	Calculated from DAT file samples	Not exported
	Count	Int32	Calculated from DAT file samples	Not exported
DespikedVelocity: X: MeasurementValueSummary	Min	Double	Calculated from DAT file samples	Not exported
	Max	Double	Calculated from DAT file samples	Not exported
	Average	Double	Calculated from DAT file samples	Export
	StandardDeviation	Double	Calculated from DAT file samples	Not exported
	Count	Int32	Calculated from DAT file samples	Not exported
	DespikedVelocity: Y: MeasurementValueSummary	Min	Double	Calculated from DAT file samples
DespikedVelocity: Y: MeasurementValueSummary	Max	Double	Calculated from DAT file samples	Not exported
	Average	Double	Calculated from DAT file samples	Export
	StandardDeviation	Double	Calculated from DAT file samples	Not exported
	Count	Int32	Calculated from DAT file samples	Not exported
	DespikedVelocity: Z: MeasurementValueSummary	Min	Double	Calculated from DAT file samples
DespikedVelocity: Z: MeasurementValueSummary	Max	Double	Calculated from DAT file samples	Not exported
	Average	Double	Calculated from DAT file samples	Export
	StandardDeviation	Double	Calculated from DAT file samples	Not exported
	Count	Int32	Calculated from DAT file samples	Not exported
	Temperature: MeasurementValueSummary	Min	Double	Calculated from DAT file samples
Temperature: MeasurementValueSummary	Max	Double	Calculated from DAT file samples	Not exported
	Average	Double	Calculated from DAT file samples	Export
	StandardDeviation	Double	Calculated from DAT file samples	Not exported
	Count	Int32	Calculated from DAT file samples	Not exported
	Pressure: MeasurementValueSummary	Min	Double	--
Pressure: MeasurementValueSummary	Max	Double	--	Not exported
	Average	Double	--	Not exported
	StandardDeviation	Double	--	Not exported
	Count	Int32	--	Not exported
	BatteryVoltage: MeasurementValueSummary	Min	Double	Calculated from DAT file samples
BatteryVoltage: MeasurementValueSummary	Max	Double	Calculated from DAT file samples	Not exported
	Average	Double	Calculated from DAT file samples	Export
	StandardDeviation	Double	Calculated from DAT file samples	Not exported
	Count	Int32	Calculated from DAT file samples	Not exported
	Tilt: MeasurementValueSummary	Min	Double	--
Tilt: MeasurementValueSummary	Max	Double	--	Not exported
	Average	Double	--	Export
	StandardDeviation	Double	--	Not exported
	Count	Int32	--	Not exported
	Pressure:	Min	Double	--

Data File			Variable	Comment
Next of Kin	Variable	Base Type		
MeasurementValueSummary	Max	Double	--	Not exported
	Average	Double	--	Export
	StandardDeviation	Double	--	Not exported
	Count	Int32	--	Not exported
ProbeDepth: MeasurementValueSummary	Min	Double	--	Not exported
	Max	Double	--	Not exported
	Average	Double	--	Export
	StandardDeviation	Double	--	Not exported
	Count	Int32	--	Not exported
Beam0: MeasurementValueSummary	Min	Double	Calculated from DAT file samples	Not exported
	Max	Double	Calculated from DAT file samples	Not exported
	Average	Double	Calculated from DAT file samples	Export
	StandardDeviation	Double	Calculated from DAT file samples	Export
	Count	Int32	Calculated from DAT file samples	Not exported
Beam1: MeasurementValueSummary	Min	Double	Calculated from DAT file samples	Not exported
	Max	Double	Calculated from DAT file samples	Not exported
	Average	Double	Calculated from DAT file samples	Export
	StandardDeviation	Double	Calculated from DAT file samples	Export
	Count	Int32	Calculated from DAT file samples	Not exported
Beam2: MeasurementValueSummary	Min	Double	Calculated from DAT file samples	Not exported
	Max	Double	Calculated from DAT file samples	Not exported
	Average	Double	Calculated from DAT file samples	Export
	StandardDeviation	Double	Calculated from DAT file samples	Export
	Count	Int32	Calculated from DAT file samples	Not exported
Calculations: PointMeasurementCalculations	Warnings	QualityControlWarnings	--	Not exported
	Velocity	XyzData	SUM.Vel (VelX, VelY, VelZ in General mode)	
	VelocityStandardError	XyzData	SUM.Verr (VxErr, VyErr, VzErr in General mode)	
	FlowAngle	Double	DIS.Angle	
	Snr	BeamData	SUM.Snr (Snr1, Snr2, Snr3 in General mode)	
	SnrStandardDeviation	BeamData	SUM.ASD1, ASD2, ASD3	
	Samples	Int32	DIS.NPts	
	Spikes	Int32	DIS.Spike	
	Tilt	Double	--	
	BoundaryAvoidance	BoundaryAvoidanceStatus	DIS.Bnd	
Boundary: BoundaryData	BoundaryRange	Double	--	Not exported
	VelocityAmbiguity	Double	--	Not exported

Data File			Variable	Comment
Next of Kin	Variable	Base Type		
	VelocityResolution	Double	--	Not exported
Beams: ReadOnlyCollection<BeamStatistics>	NoiseLevel	Double	--	
	PeakLocation	Double	--	
	PeakLevel	Double	--	
HandheldInfo: HandheldInfoSummary	SoftwareVersion:	String	DIS.SoftwareVer	Not exported (pmd value exported)
	WadingRod	WadingRod	WadingRod.Unknown	Unknown is assigned, wading rod not defined in FT1
	Units	UnitType	DIS.UnitSystem	
ProbeInfo: ProbeInfoSummary	SerialNumber	String	CTL.AdvSerialnumber	
	FirmwareVersion	String	CTL.CpuFirmwareVersion	
	NumberOfBeams	Int32	CTL.AdvNumberOfBeams	
NominalBeamStatistics: ReadOnlyCollection<BeamStatistics>	NoiseLevel	Double	--	
	PeakLocation	Double	--	
	PeakLevel	Double	--	
Calculations: StationCalculations	Warnings	QualityControlWarnings	--	Not exported
	MeanVelocityInVertical	XyzData	--	Not exported
	MeanPanelVelocity	XyzData	DIS.MeanV	Only Vx is exported
	Width	Double	--	Not exported
	Area	Double	DIS.Area	
	Discharge	Double	DIS.Flow	
	FractionOfTotalDischarge	Double	DIS.%Q	
	Snr	BeamData	--	Not exported
	Temperature	Double	--	Not exported
	VelocityAngle	Double	--	Not exported
	BoundaryAvoidance	BoundaryAvoidanceStatus	DIS.Bnd	Not exported
	Samples	Int32	--	Not exported
	Spikes	Int32	--	Not exported
	Tilt	Double	--	Not exported
VelocityStandardError	XyzData	--	Not exported	
SupplementalDataRecord: List<SupplementalDataRecord> (optional)	Time	DateTime	record yyyy/MM/dd HH:mm:ss	
	GaugeHeight	Double	record GaugeHeigh	
	RatedDischarge	Double	record RatedDischarge	
	Temperature	Double	--	
	Salinity	Double	--	
Calculations: DataFileCalculations	Comment	String	record Comment	
	Warnings	QualityControlWarnings	use the final DIS.BeamCheck as AutoQC, plus the	

Data File			Variable	Comment
Next of Kin	Variable	Base Type		
			DIS.MeanBoundary as SmartQC, plus FT2 SmartQC.	
	Area	Double	DIS.TotalArea	
	Discharge	Double	DIS.TotalDischarge	
	Width	Double	DIS.TotalWidth	
	Velocity	XyzData	DIS.MeanVelocity (or DIS.MeanVelocityVx, DIS.MeanVelocityVy in General Mode)	
	VelocityStandardError	XyzData	DIS.MeanVerr	
	Depth	Double	DIS.MeanDepth	
	Snr	Double	DIS.MeanSnr	
	Temperature	Double	DIS.MeanTemperature	
	RatedDischarge	Double	--	
GaugeHeight	Double	--		
UncertaintyIso: DischargeUncertaintyCalculations	Accuracy	Double	DIS.UncertaintyIso.Accuracy	
	Depth	Double	DIS.UncertaintyIso.Depth	
	Velocity	Double	DIS.UncertaintyIso.Velocity	
	Width	Double	DIS.UncertaintyIso.Width	
	Method	Double	DIS.UncertaintyIso.Method	
	NumberOfStations	Double	DIS.UncertaintyIso.#_Stations	
	Overall	Double	DIS.UncertaintyIso.Overall	
UncertaintyIve: DischargeUncertaintyCalculations	Accuracy	Double	DIS.UncertaintyIve.Accuracy	
	Depth	Double	DIS.UncertaintyIve.Depth	
	Velocity	Double	DIS.UncertaintyIve.Velocity	
	Width	Double	DIS.UncertaintyIve.Width	
	Method	Double	DIS.UncertaintyIve.Method	Not exported (not in IVE)
	NumberOfStations	Double	DIS.UncertaintyIve.#_Stations	Not exported (not in IVE)
	Overall	Double	DIS.UncertaintyIve.Overall	
BeamChecks: List<BeamCheckSummary>	Id	Guid	--	
	Time	DateTime	DIS.BeamCheck	
	NumberOfSamples	Int32	--	
	AutoQualityControlWarnings	QualityControlWarnings	DIS.BeamCheck	
AirPressureMeasurements:List<Pressure Reading>	Time	DateTime	--	
	Pressure	Double	--	

Point Measurement Details			Variable	Comment
Next of Kin	Variable	Base Type		
	Id	Guid	--	Not exported
	SamplingRate	Double	1.0/CTL.SampleInterval	Not exported
Samples: ReadOnlyCollection<Sample>	Time	DateTime	DAT.ymdhms	
Adv: AdvData	Velocity	XyzData	DAT.VelX, VelY, VelZ	
	Snr	Double	DAT.Snr1, Snr2, Snr3	
Sensors: SensorData	Temperature	Double	SUM.Temp	Not exported
	SoundSpeed	Double	--	Not exported
	Pressure	Double	--	Not exported
	Voltage	Double	SUM.Batt	Not exported
	Accelerometer	XyzData	--	
Diagnostics: DiagnosticsSample	Time	DateTime	--	Not exported
Adv: AdvData	Velocity	XyzData	--	Not exported
	Snr	Double		Not exported
Sensors: SensorData	Temperature	Double	SUM.Temp	Not exported
	SoundSpeed	Double	--	Not exported
	Pressure	Double	--	Not exported
	Voltage	Double	SUM.Batt	Not exported
	Accelerometer	XyzData	--	Not exported
Diagnostics: DiagnosticsSample	Boundary	BoundaryData	--	Not exported
	ProfileRange: ReadOnlyCollection	Double	--	
Statistics: BeamStatistics	NoiseLevel	Double	--	Not exported
	PeakPosition	Double	--	Not exported
	PeakLevel	Double	--	Not exported
Beams: ReadOnlyCollection<DiagnosticsBeamData>	Profile: ReadOnlyCollection	Double	--	Not exported
DataCollectionConfiguration: DataCollectionConfiguration (optional)			--	
HandheldInfo: HandheldInfo	SerialNumber	String	CTL.SerialNumber	
	SoftwareVersion	String	CTL.SoftwareVer	
	BoardsInfo	String	CTL.CpuBoardRev	Not exported
	CpuSerialNumber	String	--	
	OperatingSystem	String	--	
	Settings	Object	--	Not exported
ProbeInfo: ProbeInfo	InstrumentType	String	CTL.AdvProbeType	Not exported

Point Measurement Details			Variable	Comment
Next of Kin	Variable	Base Type		
	SerialNumber	String	CTL.AdvSerialNumber	Not exported
	FirmwareVersion	String	CTL.CpuFirmwareVersion	Not exported
	NumberOfBeams	Int32	CTL.AdvNumberOfBeams	Not exported
	IsPressureSensorPresent	Boolean	--	
	PressureSensorLocation	XyzData	--	
	ProbeBottomZ	Double	--	
NominalBeamStatistics: ReadOnlyCollection<BeamStatistics>	NoiseLevel	Double	--	Not exported
	PeakPosition	Double	--	Not exported
	PeakLevel	Double	--	Not exported
ProbeInfo: ProbeInfo	RawConfiguration	Object (optional)	--	Not exported
	Spikes: ReadOnlyCollection	Int32	Set by FT2 de-spike	Not exported
	AirPressure	Double	--	
	SiteLocation: GpsRecord	Object (optional)	--	
	ProbeDepths: ReadOnlyCollection	Double	--	

Section 13. Principle of Operations

13.1. FlowTracker2 Overview

The FlowTracker2 Handheld ADV is a single-point Doppler current meter designed for field velocity measurements. The FlowTracker2 uses the proven Doppler technology of the SonTek Acoustic Doppler Velocimeter (ADV), the leading high-resolution velocity sensor. ADV technology provides several advantages.

- Accurate velocity measurements in a remote sampling volume,
- 2D or 3D velocity measurements (depending on probe configuration),
- Invariant factory calibration, no periodic recalibration required,
- Rapid response time,
- Simple operation,
- Excellent performance for low and high flows – accuracy 1% of measured velocity,
- Built-in temperature sensor.

The FlowTracker2 offers ADV performance from a simple handheld interface, allowing rapid data collection without the use of a computer. Some common applications include:

- River discharge measurements (using established methodology, including USGS/ISO),
- Open-channel flow measurements,
- Current measurements in large pipes,
- Rapid, multi-point current surveys,
- Current monitoring in water treatment facilities.

13.2. The Doppler Shift

The FlowTracker2 uses a highly sophisticated form of this technique, which processes underwater sound (sonar) reflected from particulate matter suspended in the water.

- The Doppler principle says that if a source of sound is moving relative to the receiver, the frequency of the sound at the receiver is shifted from the transmit frequency.

$$F_{doppler} = F_{source} \times \left(\frac{V}{C}\right)$$

where,

- $F_{doppler}$ = change in received frequency (Doppler shift),
- F_{source} = frequency of transmitted sound,
- V = velocity of source relative to receiver,
- C = speed of sound.

- b) The velocity, V , represents the relative speed between source and receiver (motion that changes the distance between the two).
 - i). If the distance between the two objects is decreasing, frequency increases.
 - ii). If the distance is increasing, frequency decreases.
 - iii). Motion perpendicular to the line connecting source and receiver does not introduce a Doppler shift.

13.3. Bistatic Doppler Current Meters

13.3.1 Bistatic Doppler Operation

The FlowTracker2 is a Bistatic Doppler current meter with the 2D side looking probe design and sampling volume shown in [Figure 13:1](#).

- a) Bistatic means separate acoustic transducers are used for transmitter and receiver.
- b) The transmitter generates sound concentrated in a narrow beam.
- c) The receivers are sensitive to sound coming from a narrow beam.
- d) The receivers are mounted such that the beams intersect at a volume of water located a fixed distance (10 cm; 4 in) from the tip of the probe.
- e) The beam intersection determines the location of the sampling volume (the volume of water in which measurements are made).

13.3.2 The FlowTracker2 Measurement Principle

- a) The transmitter generates a short pulse of sound at a known frequency.
- b) The sound travels through the water along the transmitter beam axis.
- c) As the pulse passes through the sampling volume, sound is reflected in all directions by particulate matter (sediment, small organisms, bubbles).
- d) Some portion of the reflected energy travels back along the receiver beam axes.
- e) The reflected signal is sampled by the acoustic receivers.
- f) The FlowTracker2 measures the change in frequency (Doppler shift) for each receiver.
- g) The Doppler shift is proportional to the velocity of the particles along the bistatic axis of the receiver and transmitter. The bistatic axis is located halfway between transmit and receive axes.
- h) Knowing the relative orientation of the bistatic axes allows the FlowTracker2 to calculate 2D or 3D water velocity.

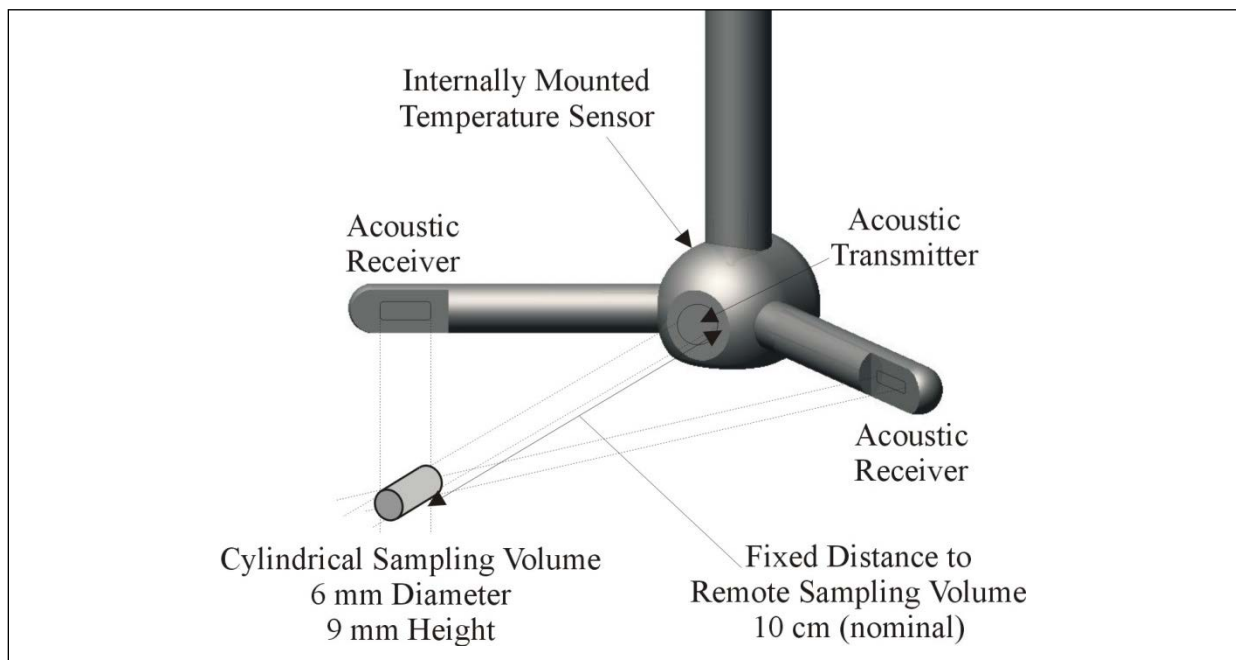

Figure 13:1 - 2D Side Looking Probe and Sampling Volume

13.3.3 Signal to Noise Ratio Profile

The signal to noise ratio versus time profile plot for the FlowTracker2 is shown in [Figure 13:2](#).

- a) The horizontal axis shows time after the transmit pulse.
- b) The vertical axis shows the return signal strength measured by one receiver.
- c) As the transmit pulse travels through the water, sound is reflected in all directions.
- d) Immediately following the transmit pulse, reflections come from outside the receiver beam. The receiver measures only the ambient noise level.
- e) As the pulse propagates along the transmit axis, it moves closer to the receiver beam. The receiver sees an increase in signal strength.
- f) Signal strength reaches a maximum at the intersection of transmit and receive beams.
- g) By sampling the return signal at its peak, the FlowTracker2 makes measurements in the sampling volume defined by the intersection of transmit and receive beams.

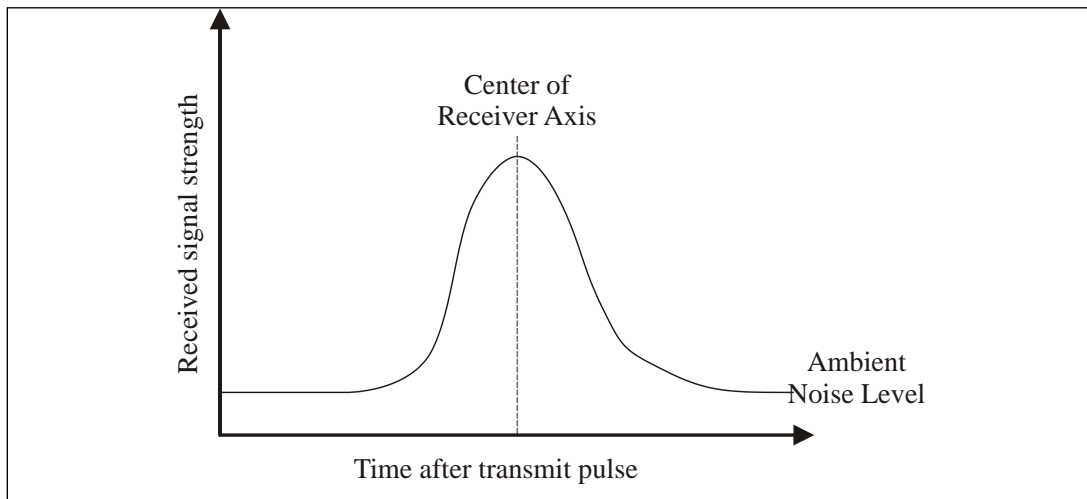

Figure 13:2 - Signal to Noise Ratio Profile

13.4. Pulse-Coherent Processing

This section does not attempt to provide a detailed description of pulse-coherent processing. It presents a simple overview with a focus on how this affects FlowTracker2 operation. SonTek can provide additional information on request.

The description of FlowTracker2 operation given in [Bistatic Doppler Current Meters](#) is an oversimplification.

- [Bistatic Doppler Current Meters](#) describes incoherent Doppler processing in which the transducer sends a single pulse of sound and measures the frequency change of the return signal.
- The FlowTracker2 uses a technique called pulse-coherent processing.

Pulse-coherent processing provides the best possible performance of any Doppler processing technique. In the simplest terms, pulse-coherent processing works as follows.

- a) The FlowTracker2 sends two pulses of sound separated by a time lag (τ).
- b) Each receiver measures the phase (ϕ) of the return signal from each pulse.
- c) The change in phase ($\phi_2 - \phi_1$) divided by the time lag (τ) is proportional to velocity.
- d) Because of the nature of the phase measurement (which can only be determined from -180° to $+180^\circ$), the system has an inherent maximum velocity limitation.
- e) The FlowTracker2 velocity algorithms have been optimized to give the best possible performance over a wide velocity range of ± 4.0 m/s (± 13 ft/s).
- f) FlowTracker2 processing provides unmatched results for low flows (< 1 cm/s; < 0.03 ft/s).

FlowTracker2 processing has been designed to give the best possible performance in all environments. However, there is a situation where system performance may be affected by operating conditions.

- When working near boundaries or underwater obstacles, the system may need to adapt its operation to avoid acoustic interference.
- This is called boundary adjustment and is performed automatically by the system at each measurement location.
- The system reports a quality control parameter with each measurement location that tells you if the environment has any effect on FlowTracker2 performance. This quality control parameter is described in [Boundary Interference](#).

13.5. Beam Geometry and 3D Velocity Measurements

A single transmit/receive pair measures the projection of the 3D water velocity onto the bistatic axis.

- The bistatic axis is halfway between transmit and receive beam axes (see [Figure 13:3](#)).
- The velocity measured by each receiver is called the bistatic velocity.
- The FlowTracker2 uses one transmitter and two or three receivers (for 2D or 3D probes).
- See [Probe Configurations](#) for other FlowTracker2 probe configurations.
- Receivers intersect with the transmit beam pattern at a common sampling volume.
- Bistatic velocities are converted to Cartesian (XYZ) velocities using the probe geometry (the relative angles of transmit and receive beams). Cartesian velocities give the 2D or 3D velocity relative of the FlowTracker2 probe.
- During the manufacturing process, probe geometry is precisely determined by a calibration procedure.
- This calibration only needs to be performed once.
- No periodic re-calibration is required.

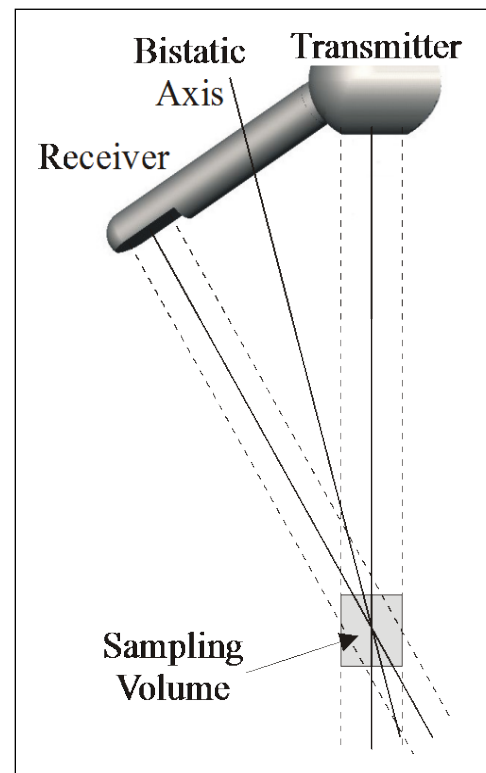

Figure 13:3 - Bistatic Axis

13.6. Sampling Volume Definition

The FlowTracker2 sampling volume is defined based on the following criteria,

- The sampling volume is nominally 10 cm (4 in) from the tip of the probe.
- The exact location varies ± 1.0 cm (± 0.4 in) from probe to probe.
- Precise sampling volume location is fixed for any given probe.

- d) The physical size of the sampling volume is a cylinder 6 mm (0.24 in) in diameter by 9mm (0.35 in) in length (see [Figure 13:1](#)).

13.7. Velocity Data Coordinate System

FlowTracker2 velocity measurements are reported using a right-hand Cartesian coordinate system relative to the probe. The XYZ coordinate systems for each probe type are shown below.

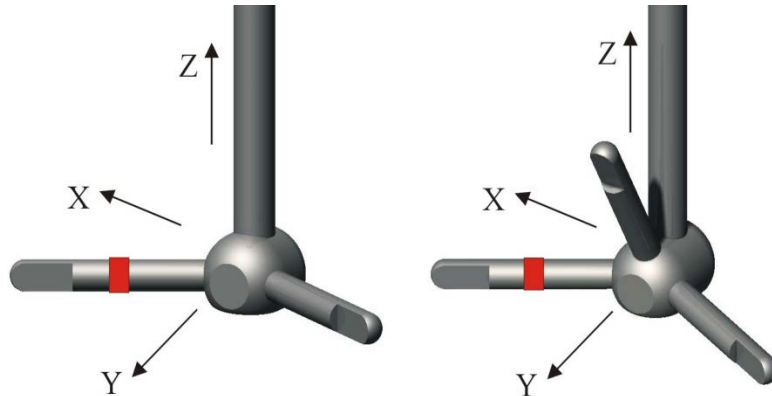

Figure 13:4 - FlowTracker2 Probe XYZ Coordinate System

13.7.1 2D Side-Looking Probe (Figure 30a)

- The positive Z-axis is defined as vertically up in the direction of the probe's stem.
- The positive X-axis is defined perpendicular to both the probe's stem and the axis of the transmit transducer in the direction of receiver arm #1 (marked with a red band).
- The positive Y-axis is defined along the axis of the transmit transducer from the transmitter towards the sampling volume (making a right-handed coordinate system).

13.7.2 2D/3D Side-Looking Probe (Figure 30b)

- The positive Z-axis is defined as vertically up in the direction of the probe's stem.
- The positive X-axis is defined perpendicular to both the probe's stem and the axis of the transmit transducer in the direction of receiver arm #1 (marked with a red band).
- The positive Y-axis is defined along the axis of the transmit transducer from the transmitter towards the sampling volume (making a right-handed coordinate system).

13.8. FlowTracker2 Data

13.8.1 Basic Sampling Strategy

The FlowTracker2 collects a burst of velocity data at each measurement location. The sampling strategy for the FlowTracker2 instruments is summarized in [Table 13:1](#). The Original FlowTracker sampling strategy is included for comparison.

Table 13-1- Sampling Strategy

Category	FlowTracker2			Original FlowTracker		
	Sampling Rate	Pings per Sample	Ping Rate	Sampling Rate	Pings per Sample	Ping Rate
Field	2 Hz	20	40 Hz	1 Hz	10	10 Hz

- An individual measurement of the 2D or 3D velocity is referred to as a ping.
- Sample refers to the mean of 20 pings to produce a measurement of the 2D or 3D water velocity.
- Two samples are recorded per second during the user specified averaging time.
- The averaging time at each location is user-specified (10 to 1000 seconds).
- The system collects a time-series of velocity at each measurement location over the user specified averaging interval.

13.8.2 Velocity Data

The FlowTracker2 provides several important performance advantages.

- It can measure 2D or 3D water velocities from 0.001 to 4.0 m/s (0.003 to 13 ft/s).
- Velocity data are accurate to 1% of the measured velocity in a one-second sample.
- Velocity data can be used immediately without any post processing corrections.
- True 2D or 3D velocity data are output in Cartesian coordinates (XYZ) relative to probe orientation.
- The FlowTracker2 calibration will not change unless the probe is physically damaged. No periodic calibration is required.
- Diagnostic software is included to evaluate system performance periodically.

13.8.3 Accuracy of Velocity Data

13.8.3.1 Optimizing of FlowTracker2

The FlowTracker2 has been optimized to provide the best possible velocity data.

- Velocity data are accurate to 1% of measured velocity for each one-second sample.
- Variations in velocity data are dominated by true variations in water velocity.
- Instrument noise does not normally have an impact on velocity data.

- d) The averaging time required to determine the true mean velocity at a given location is a function of the real variations in velocity at that site.

13.8.3.2 Factors Influencing Accuracy

Two factors influence accuracy of FlowTracker2 velocity data – sound speed and probe geometry.

- a) The effect of sound speed is discussed in [Sound Speed](#). With properly specified salinity data, sound speed errors are negligible (less than 0.25%).
- b) Probe geometry is calibrated at the factory for each FlowTracker; no recalibration is required unless the probe has been physically damaged.
- c) The FlowTracker2 calibration procedure is specified to $\pm 1.0\%$ of the measured velocity.
- d) There is no potential for zero offset or zero drift in velocity measurements. There is no inherent minimum measurable velocity.
- e) The FlowTracker2 is very well suited to low-flow applications to less than 1 cm/s (0.03 ft/s).

13.8.4 Quality Control Data

In addition to velocity, the FlowTracker2 records quality control data with each measurement station to quickly evaluate velocity data quality. The quality control parameter details are discussed in [Quality Control Parameters](#), Section 6, Quality Control.

13.9. Special Considerations

13.9.1 Probe Configurations

Several FlowTracker2 probe configurations are available for different applications (see [Figure 13:4](#)).

13.9.1.1 Probe mounting

- a) The probe is mounted from a 1.500m (4.92ft) flexible cable. A 3.500m (11.5ft) or 8.500m (27.9ft) extension cable is available. However, it is not possible to upgrade an existing system to a different cable length.
- b) It is not advised to exceed an overall cable length of 10.000m (32.8ft).
- c) The cable is custom built to reduce electronic noise. It should not be modified by the user.
- d) Take care to avoid damage to the cable, as this can affect system operation.

13.9.1.2 Probe type

- a) Two probe types are available (see [Figure 13:4](#)).

- b) The standard FlowTracker2 uses a 2D side-looking probe. The sampling volume is located 10 cm (4 in) to the side of the probe, and can operate in as little as 2 cm (1 in) of water.
- c) To work in both shallow and deeper water, a combination 2D/3D side-looking probe is available. This has a sampling volume located 10 cm (4 in) to the side of the probe, and can operate in as little as 2 cm (1 in) of water. It measures 2D velocity in shallow water (with only two arms submerged), and 3D velocity in deeper water (with all three arms submerged).

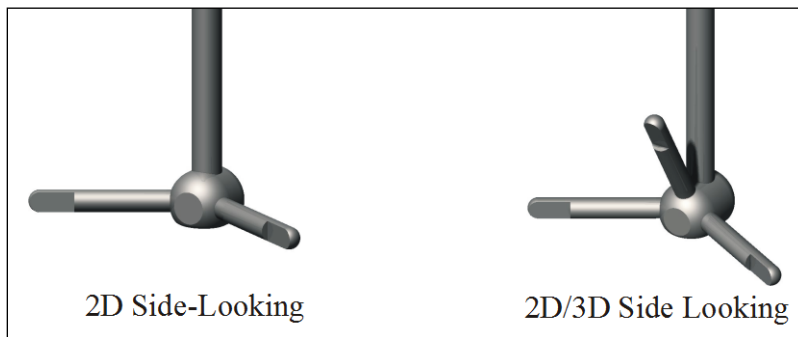

Figure 13:5 - FlowTracker2 Probe Configuration

13.10. Sound Speed

The FlowTracker2 uses sound speed to compute velocity from the measured Doppler shift, and to precisely determine the location of the sampling volume.

13.10.1 Sound Speed Function

The speed of sound in water is primarily a function of temperature and salinity.

- a) Temperatures change of 5°C (9°F) results in a sound speed change of ≈1%.
- b) A salinity change of 12 results in a change in sound speed of ≈1%.
- c) A 1% error in sound speed results in a ≈2% error in velocity data.

13.10.2 Compensate for Changes

To compensate for changing sound speed, the FlowTracker2 does the following.

- a) The FlowTracker2 includes a temperature sensor for automatic sound speed corrections. Resolution is $\pm 0.01^{\circ}\text{C}$ ($\pm 0.02^{\circ}\text{F}$).
- b) A user-input value of salinity is used for sound speed calculations.
- c) If accurate salinity data has been specified by the user (± 2), sound speed changes can be assumed to have no impact on velocity data.

13.10.3 Environmental Conditions

Doppler current meters, such as the FlowTracker2, do not measure movement of water, but actually the movement of particles **in** the water,

- We must assume that the movement of the particles in the water is representative of the movement of the water itself,
- If there are no particles (other than the water molecules themselves) present in the water, Doppler current meters will not work. Natural streams almost always have something else other than just “water” (even if just tiny air bubbles), and the technology is such that even a small amount of particles in the water is usually enough for good measurements.

Visual inspection is **not** an acceptable method for determining the amount of particles in the water and no simple relationship exists with turbidity.

- We cannot say that for a given turbidity level your water is too clear for a Doppler-based measurement.
- The amount of particles in the water is not the only factor affecting signal amplitudes. Particle size, shape, distribution, and type also control these values, and these conditions vary from site to site.
- Therefore, one stream may meet these conditions, but another with the same turbidity may not.

If the site conditions seems unsuitable for FlowTracker2 measurement due to lack of particles in the water it is recommended to perform an Automated Beam Check. If the results are within the instrument specifications and quality control parameters user can start with velocity measurements. The FlowTracker2 can return reliable measurements down to about 3 dB (in SNR), although we recommend 10 dB and above for best operating conditions.

13.11. Flow Interference

The FlowTracker measures velocity in a small sampling volume nominally located 10 cm (4 in) from the tip of the probe (see [Sampling Volume Definition](#)). The placement of the sampling volume relative to other structures in the water must be considered when measuring velocity to avoid flow interference.

13.11.1 Structures

- a) The FlowTracker probe should be located away from any underwater structures or obstacles, particularly those upstream.
- b) Consider the size and location of nearby structures and obstacles, and the probable magnitude and direction of flow, when choosing a measurement location.

13.11.2 Probe orientation relative to flow

- a) The FlowTracker should be oriented so the axis of the transmit transducer is roughly perpendicular to the expected direction of flow (see [Figure 13:6](#)).
- b) For side-looking probes (2D and 2D/3D), the probe should be oriented looking across the expected direction of flow (so the X-axis aligns with the expected flow).

- c) FlowTracker probes have been tested and have shown negligible flow interference with the probe as much as 40-50° away from the preferred alignment. At higher angles, the FlowTracker may see flow interference in the sampling volume.

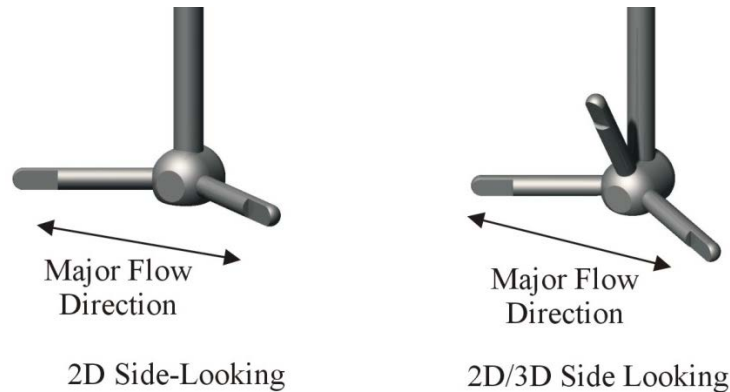

Figure 13:6 - Preferred Flow Direction to Avoid Flow Interference

13.11.3 Mounting Correction

Laboratory tow tank tests have indicated the FlowTracker2 probe and mount create flow disturbance that may have a small impact (approximately 1.0%) on measured velocity data. The mount is most commonly a top-setting wading rod using an S or J offset bracket. Additional tests and modeling have looked at whether flowing water shows the same flow disturbance effect seen in a tow tank (where the FlowTracker2 is towed through a pool of stationary water).

By default, no correction for flow disturbance is applied to FlowTracker2 data. If you are using a standard top-setting wading rod, and have decided to apply a correction, SonTek typically recommends using a correction of 1.0%. For additional information about the flow disturbance effect, contact SonTek directly.

To apply a flow disturbance correction, set the [Mounting Correction](#) from the Data Collection Settings menu.

13.11.3.1 No Correction

- With the default setting of No Correction, the FlowTracker2 velocity data is used directly without any correction for flow disturbance.

13.11.3.2 Custom Correction

- This is selected when you want to apply a correction to account for flow disturbance from the FlowTracker mount. With this option, you must specify the value of the Mounting Correction within the range -5% to +5%.
- When applied, the most common value for a standard top setting wading rod is 1.0%. A 1.0% correction means that measured velocity data is increased by 1.0% to account for the effect of flow disturbance from the wading rod.

13.12. Dynamic Pressure (Pressure Sensor)

Dynamic pressure is the kinetic energy per unit volume of fluid and affects the pressure sensor measurements performed by the FlowTracker2 ADV internal pressure sensor in flowing water. The extent of the dynamic pressure affecting the pressure sensor measurements is directly related to the water velocity. The correction for dynamic pressure on FlowTracker2 pressure sensor measurements is described in this section.

In fluid dynamics, the Total Pressure (P_0) is defined as the sum of the Static Pressure (P) and the Dynamic Pressure (P_d),

Equation 13:1 – Total Pressure

$$P_0 = P + P_d$$

The internal pressure sensor of the FlowTracker2 provides an accurate measurement of the Total Pressure (P_0). Calculating depth from pressure requires the Static Pressure (P) to be known. For still or slow moving water the Dynamic Pressure (P_d) is negligible and thus the Static Pressure (P) and the Total Pressure (P_0) are very close. Using the Total Pressure (P_0) as measured by the pressure sensor instead of the Static Pressure (P) in these cases provides a good conversion for all practical purposes.

However, for faster flowing water, ignoring the Dynamic Pressures (P_d) is not an option and would result in a significant error in the pressure-to-depth conversion. Correcting for Dynamic Pressure is essential to ensure a proper depth computation.

Dynamic Pressure (P_d) is defined as,

Equation 13:2 – Dynamic Pressure

$$P_d = 0.5 \times \text{WaterDensity} \times \text{WaterSpeed}^2$$

All parameters required in [Equation 13:2](#) are available to the FlowTracker2

- **WaterDensity** can be approximated or in the case of the FlowTracker2 is precisely computed from Salinity (user entry), Latitude and Altitude (from the integrated GPS),
- **WaterSpeed** is provided by the ADV (the main function of the FlowTracker2 is to measure water velocity). To produce a precise **WaterSpeed**, the **AdvWaterSpeed** (measured water speed) is corrected by a constant “head drag coefficient” (a) which describes the flow disturbance around the pressure sensor introduced by the ADV head and is different for different head shapes (e.g. 2D or 2D/3D).

Equation 13:3 – Corrected AdvWaterSpeed

$$\text{WaterSpeed} = \text{AdvWaterSpeed} \times a$$

If we substitute [Equation 13:3](#) in [Equation 13:2](#) the dynamic pressure can be computed using [Equation 13:4](#),

Equation 13:4 – Dynamic Pressure using AdvWaterSpeed

$$P_d = 0.5 \times WaterDensity \times (AdvWaterSpeed \times a)^2$$

Knowing the Dynamic Pressure (P_d) and the Total Pressure (P_0) – the static pressure can then be computed using [Equation 13:5](#),

Equation 13:5 – Static Pressure

$$P = P_0 - P_d$$

If we substitute [Equation 13:4](#) in [Equation 13:5](#) the final equation for correcting the pressure measured by the FlowTracker2 internal pressure sensor is defined in [Equation 13:6](#),

Equation 13:6 – Corrected Pressure

$$P = P_0 - 0.5 \times WaterDensity \times (AdvWaterSpeed \times 2)^2$$

Section 14. FlowTracker2 Desktop Software

14.1. Overview of Software Features and Functions

The FlowTracker2 Desktop Software is designed to work in conjunction with the FlowTracker2 Handheld ADV. With this software, you will be able to:

- **View, post-process, and export** FlowTracker Data,
- **Connect** to a FlowTracker Handheld ADV to download data and perform recorder functions.

The layout of the FlowTracker2 Desktop Software upon startup is shown in [Figure 14:1](#). Each function and feature of the software will be addressed in the subsequent sections.



Specific software functions will have the sequence of buttons or tabs taken to reach that function next to the function title (in blue italic font). This sequence will always start at the startup page shown in [Figure 14:1](#).

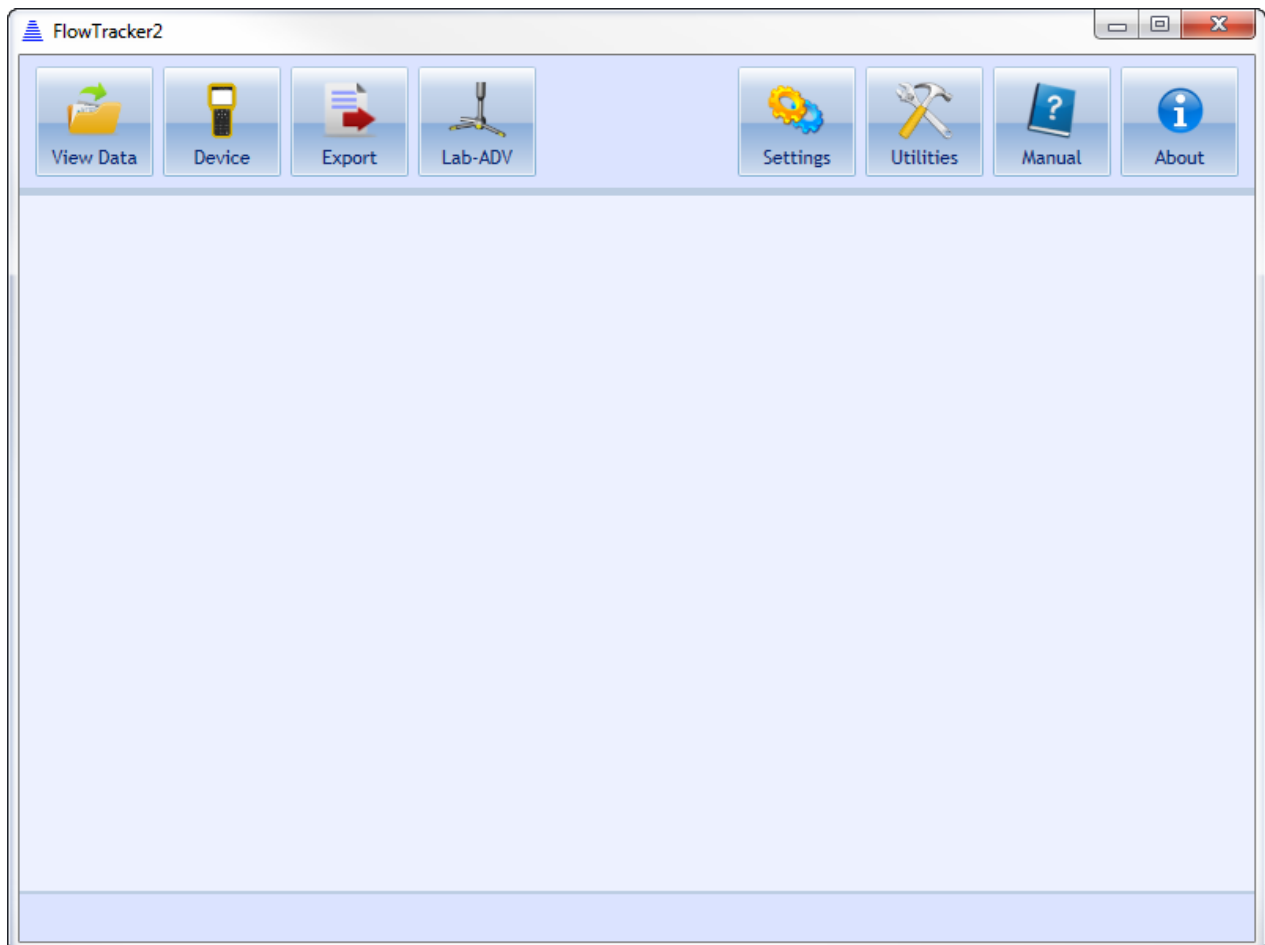

Figure 14:1 - Layout of FlowTracker2 Desktop Software upon startup

14.2. Installing Software

The FlowTracker2 Desktop Software installation file is included with the USB thumb drive that ships with your FlowTracker2 Handheld ADV. It is also available from the SonTek website (<http://www.sontek.com>). Run the **Windows Installer Package (.msi)** file corresponding to the type of computer on which you wish to install the software (**32-bit** or **64-bit**). Accept the terms in the License Agreement (shown in [Figure 14:2](#)) and click Install.

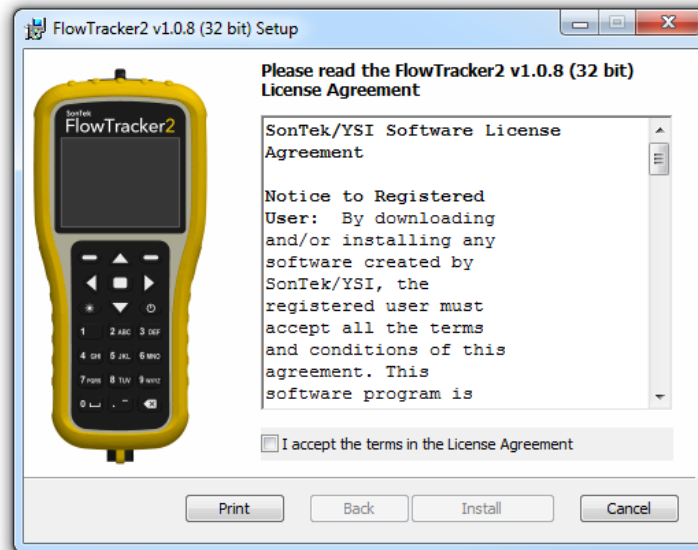

Figure 14:2. Installation Dialog for FlowTracker2 Desktop Software

During the process, you will be prompted to install a driver with the message shown in [Figure 14:3](#). **This driver must be installed in order to communicate with the FlowTracker2 Handheld ADV.**

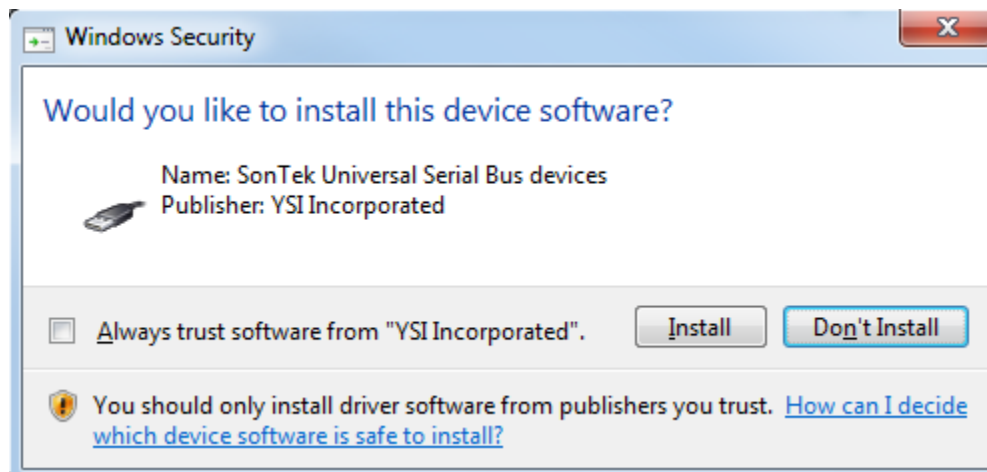

Figure 14:3. Driver Installation

14.3. Changing Settings

The Settings button opens a dialog (shown in [Figure 14:4](#)) providing options to change various software and user settings.

14.3.1 User Interface Tab

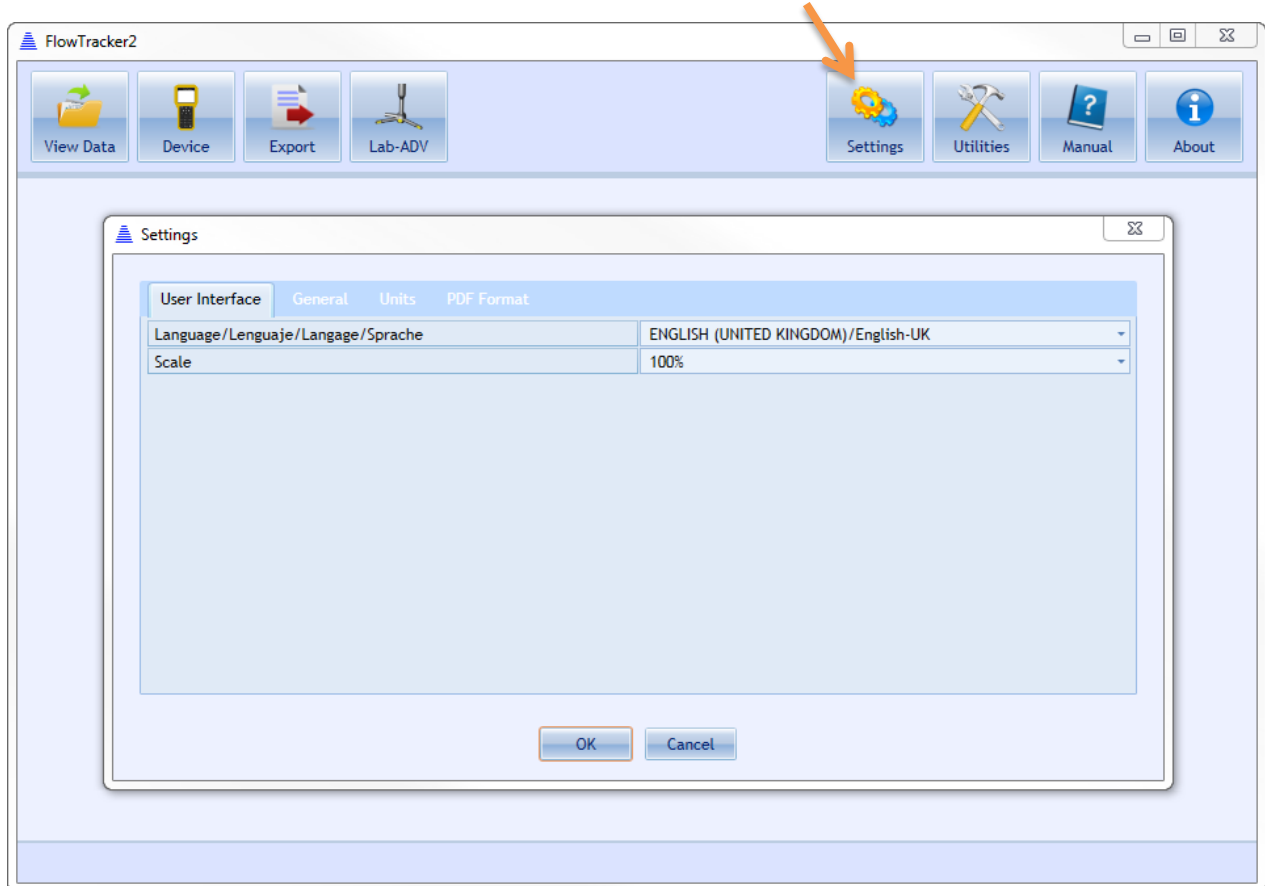

Figure 14:4. Changing User Interface Settings

14.3.1.1 Changing Language (Settings > User Interface > Language)

The **software language** can be changed through the **User Interface** tab in the **Settings** dialog. The language choices include:

- Auto Detect (using your computer settings)
- Catalan
- Chinese (simplified and traditional)
- English
- French
- German
- Greek
- Italian
- Japanese
- Korean
- Portuguese
- Romanian
- Russian
- Spanish
- Custom

For languages not included in this list (Custom), different language tools are available. These are described in detail in [Run Translator](#).

14.3.1.2 Changing Scale and Font Size (Settings > User Interface > Scale)

The **scale** of all the text and buttons can be changed through the **User Interface** tab in the **Settings dialog**. The font size and buttons can be increased up to 150% and decreased down to 60%. The software will restart automatically to implement the changes.

14.3.2 General Tab

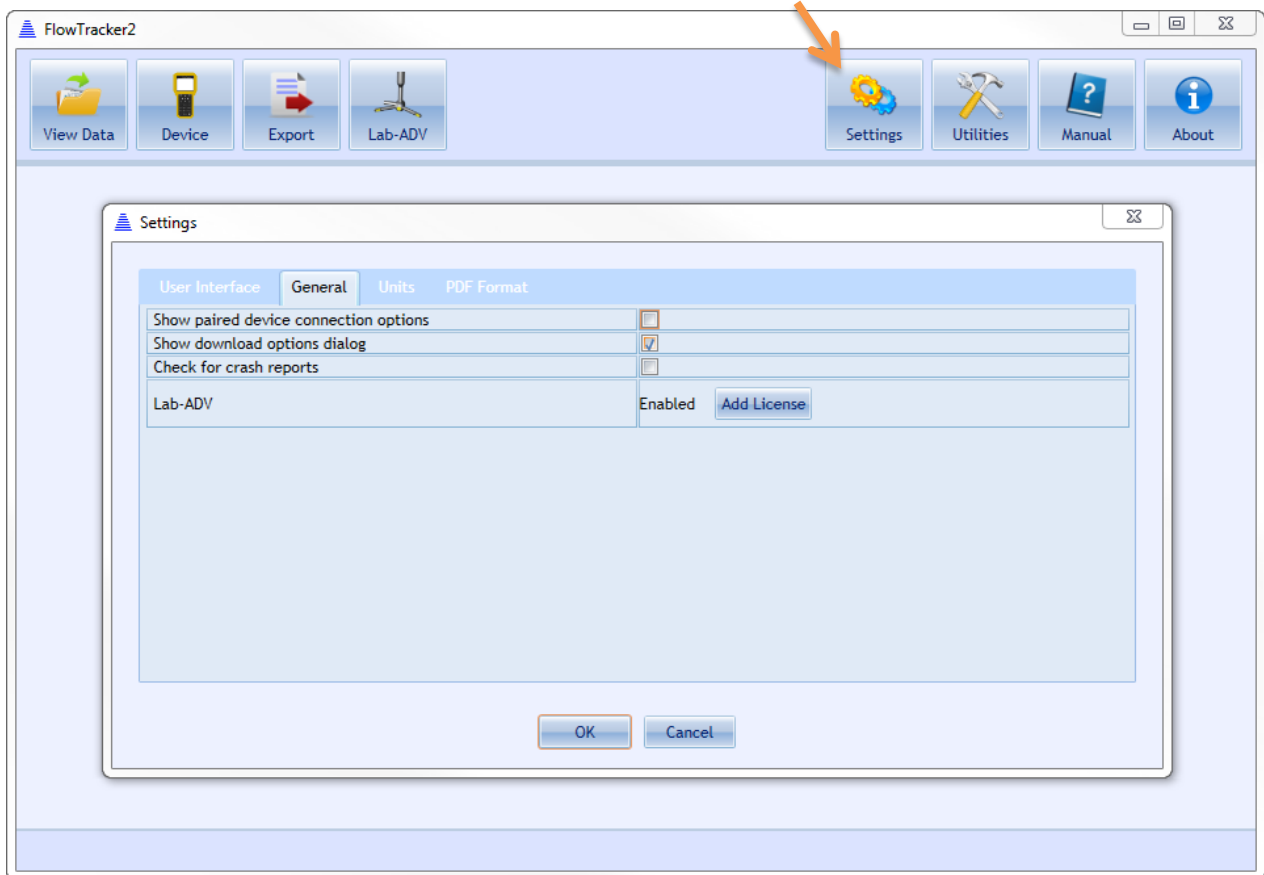

Figure 14:5. Changing General Settings

14.3.2.1 Show paired device connection options (Settings > General > Show paired device connection options)

Checking this box will provide more options during device communication using Bluetooth. It allows you to select a COM port manually if you already have a Bluetooth device paired. It is recommended that this box be left unchecked unless you are contacting Technical Support and are troubleshooting Bluetooth connectivity issues.

14.3.2.2 Show Download Options Dialog (Settings > General > Show download options dialog)

When downloading data files from the FlowTracker2 Handheld ADV, a dialog with various options appears by default. These options are described in [Download Data Files](#). This dialog can be enabled/disabled using this check box.

14.3.2.3 Check for Crash Reports and Send to SonTek Support (Settings > General > Check for crash reports)

Crash reports are automatically generated by the FlowTracker2 software. If the **Check for crash reports** option is toggled on, upon startup, the software will search for crash reports. If crash reports are found, the dialog in [Figure 14:6](#) will appear, prompting for the option to send crash reports to SonTek Technical Support.

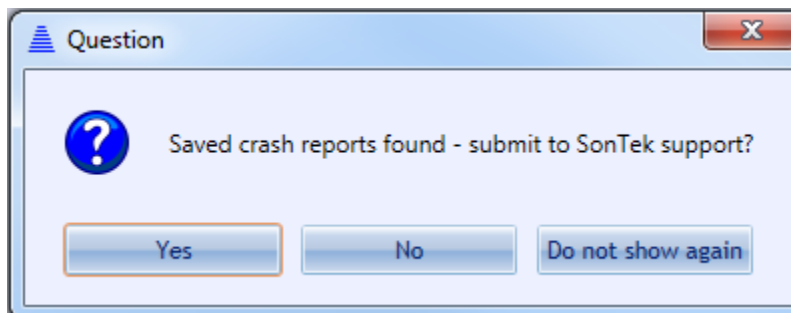

Figure 14:6. Crash report dialog

Toggling this option off will disable this prompt upon startup of the software. Clicking **Do not show again** will uncheck the box in the General Settings tab.

14.3.2.4 Lab-Adv (Settings > General > Lab-Adv)

The Lab-ADV feature is enabled by uploading the license file into the FlowTracker2 Desktop Software. The upload of license file can be performed from the Settings menu under the General tab, shown in [Figure 14:5](#). Please see [FlowTracker2 Lab-ADV](#) for instructions on how to use this feature.

14.3.3 Units Tab

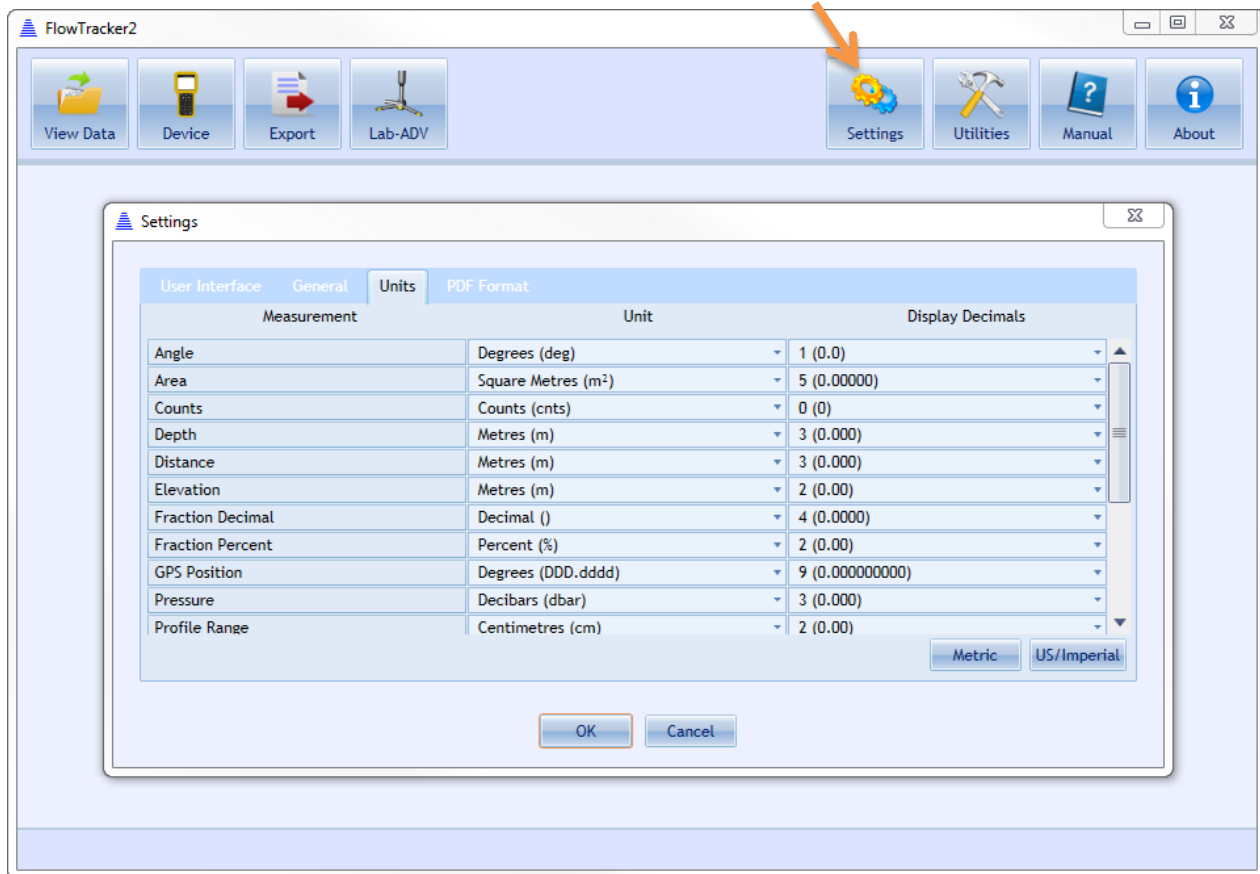

Figure 14:7. Changing Units

14.3.3.1 Changing Software Units (Settings > Units)

The units displayed by the software for various parameters can be changed independently. [Table 14:1](#) summarizes the changeable parameters and what unit options are available.

Table 14-1- Units Available for Software Parameters

Measurement	Unit Options
Angle	Degrees (deg), Radians (rad)
Area	Square feet (ft ²), Square meters (m ²)
Counts	Counts (cnts)
Depth	Centimeters (cm), Fathoms (fms), Feet (ft), Inches (in), Kilometers (km), Meters (m), Miles (miles), Millimeters (mm), Yards (yd)
Distance	Centimeters (cm), Fathoms (fms), Feet (ft), Inches (in), Kilometers (km), Meters (m), Miles (miles), Millimeters (mm), Yards (yd)
Flow	Acre feet per day (acre ft/day), Acre feet per hour (acre ft/hour), Cubic feet per second (ft ³ /s), Cubic

Measurement	Unit Options
	meters per second (m ³ /s), Liters per second (L/s), Megaliters per day (ML/day), Million UK gallons per day (Million UK gallons/day), Million US gallons per day (Million US gallons/day), UK gallons per minute (UK gallons/min), US gallons per minute (US gallons/min)
Fraction Decimal	Decimal (), Percent (%)
Fraction Percent	Decimal (), Percent (%)
GPS Position	Degrees (DDD.dddd), Degrees minutes (DDD MM.mmmm), Degrees minutes seconds (DDD MM SS.ss)
Pressure	Bar (bar), Decibars (dbar), Feet of water (ft H ₂ O), Meters of water (m H ₂ O), Pascal (Pa), Pound Force per Square Inch (psi)
Salinity	Practical Salinity Scale (pss)
SNR	Decibels (dB)
Sound Speed	Centimeters per second (cm/s), Feet per second (ft/s), Furlongs per fortnight (furlongs/fortnight), Inches per second (in/s), Kilometers per hour (km/h), Knots (kt), Meters per second (m/s), Miles per hour (mph), Millimeters per second (mm/s), Yards per second (yd/s)
Temperature	Celsius (°C), Fahrenheit (°F), Kelvin (°K)
Time Span	Seconds (s)
Voltage	Millivolts (mV), Volts (V)
Water Velocity	Centimeters per second (cm/s), Feet per second (ft/s), Furlongs per fortnight (furlongs/fortnight), Inches per second (in/s), Kilometers per hour (km/h), Knots (kt), Meters per second (m/s), Miles per hour (mph), Millimeters per second (mm/s), Yards per second (yd/s)

To change units, click on the appropriate drop-down menu and select the unit desired. There is an option on the lower right to change all relevant units to Metric or US/Imperial. Click OK, and the software will automatically restart to apply the changes.

14.3.3.2 Changing Software Display Decimals (Settings > Units)

The number of decimals displayed by the software for various parameters can be changed independently. Display decimals can be changed for all parameters listed in [Table 14:1](#). The display decimals range from 0 (0) to 9 (0.000000000). To change the number of decimals displayed, click on the appropriate drop-down menu and select the value desired. When display decimals are changed, the software will automatically restart to apply those changes.

14.3.4 PDF Format

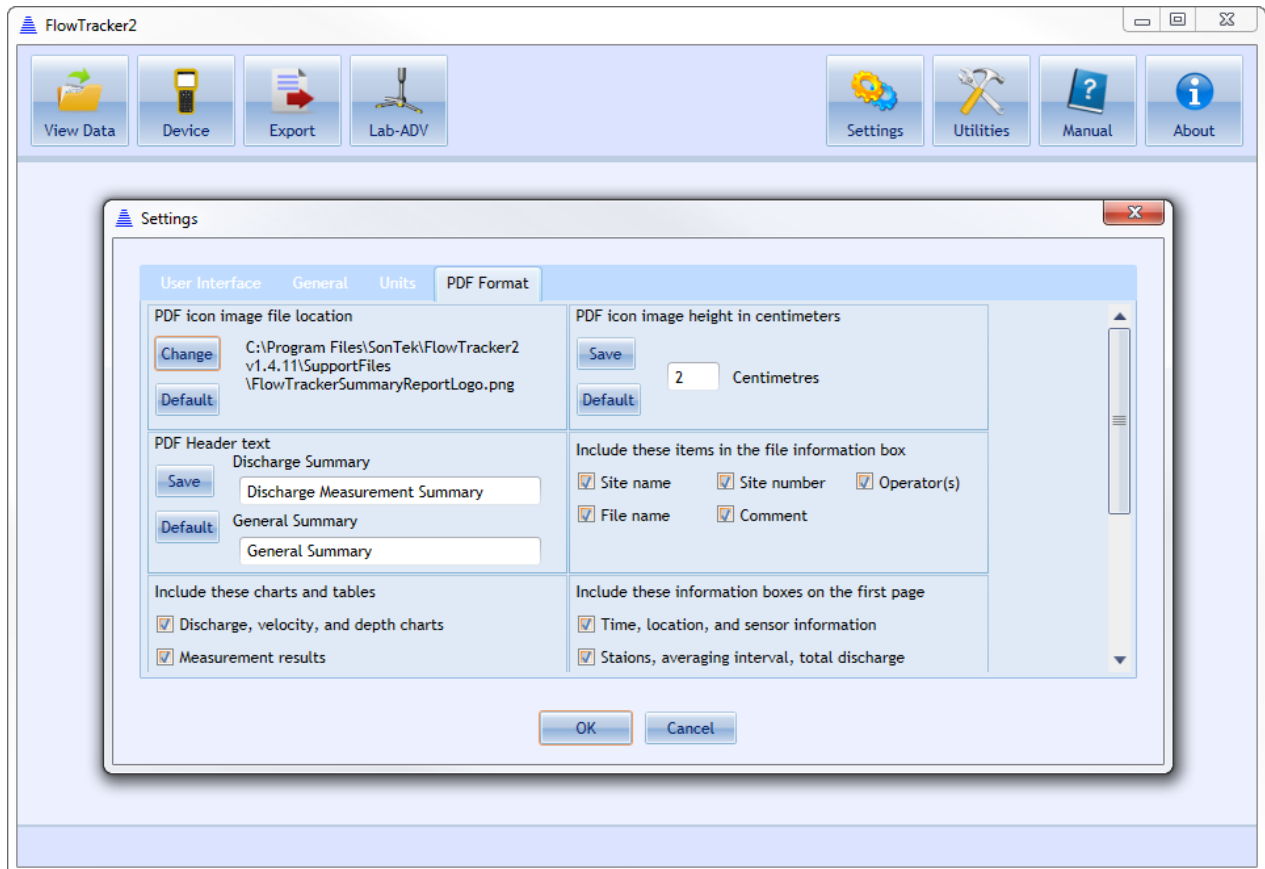

Figure 14:8. PDF Format

14.3.4.1 Icon Image (Settings > PDF Format > PDF icon image file location)

The “PDF Icon Image File Location” allows an organization to incorporate their logo in the PDF Discharge Measurement Summary report. The image format accepted for organization logo is “png”.

The network path where the organization logo should be stored on user operating platform is the following,

C:\Program Files\SonTek\FlowTracker2 v1.6\SupportFiles

14.3.4.2 Image Height (Settings > PDF Format > PDF icon image height in centimeters)

The “PDF Icon Image Height in Centimeters” feature configures the image height in centimeters that is displayed on the PDF report.

The PDF icon image height is user configurable or based on FlowTracker2 default settings. It is important to save the configuration changes for implementation.

14.3.4.3 Header Text (Settings > PDF Format > PDF Header Text)

The “PDF Header Text” feature enable users to personalize the PDF report heading.

The PDF Header text is user configurable or based on FlowTracker2 default settings. It is important to save the configuration changes for implementation.

14.3.4.4 Include File Information (Settings > PDF Format > Include these items in the file information box)

The “File Information” available for inclusion on the PDF report consists of Site Name, Site Number, Operator, File Name and Comments. Select the checkbox to either include or exclude the information from the report.

14.3.4.5 Include Charts and Tables (Settings > PDF Format > Include these charts and tables)

The “Charts and Tables” available for inclusion on the PDF report consists of the following. Select the checkbox to either include or exclude the information from the report.

- Discharge, Velocity and Depth Charts,
- Measurement Results,
- Quality Control Warnings,
- Automated Beam Check, Air Pressure Measurements
- Supplemental Data Summary.

14.3.4.6 Include Information Boxes (Settings > PDF Format > Include these information boxes on the first page)

The “Information” available for inclusion on the first page of the PDF report consists of the following. Select the checkbox to either include or exclude the information from the report.

- Time, Location and Sensor Information,
- Stations, Averaging Interval, Total Discharge,
- Total Width, Total Area, Wetted Perimeter,
- Mean SNR, Mean Depth, Mean Velocity,
- Mean Temperature, Max Depth, Max Velocity,
- Discharge Uncertainty and Settings,
- Summary Overview,

- Configuration Changes.

14.4. Utilities

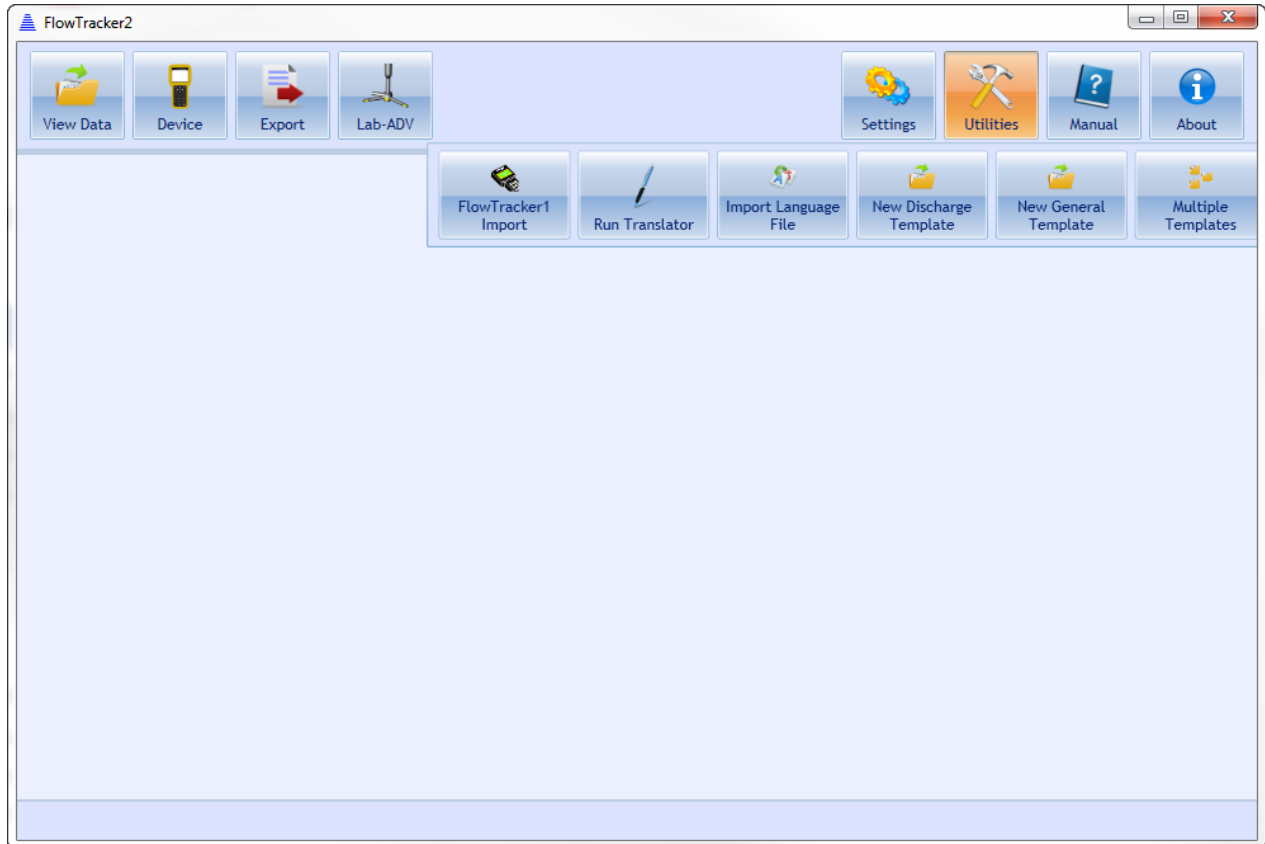

Figure 14:9. Utilities Dialog

14.4.1 FlowTracker1 Import (Utilities > FlowTracker1 Import)

This is a conversion tool allowing users to open measurements taken by the Original FlowTracker Handheld ADV instrument with the .wad extension. Please see [Opening Original FlowTracker Handheld ADV Data Files \(.WAD files\)](#) for instructions on how to use this feature.

14.4.2 Run Translator (Utilities > Run Translator)

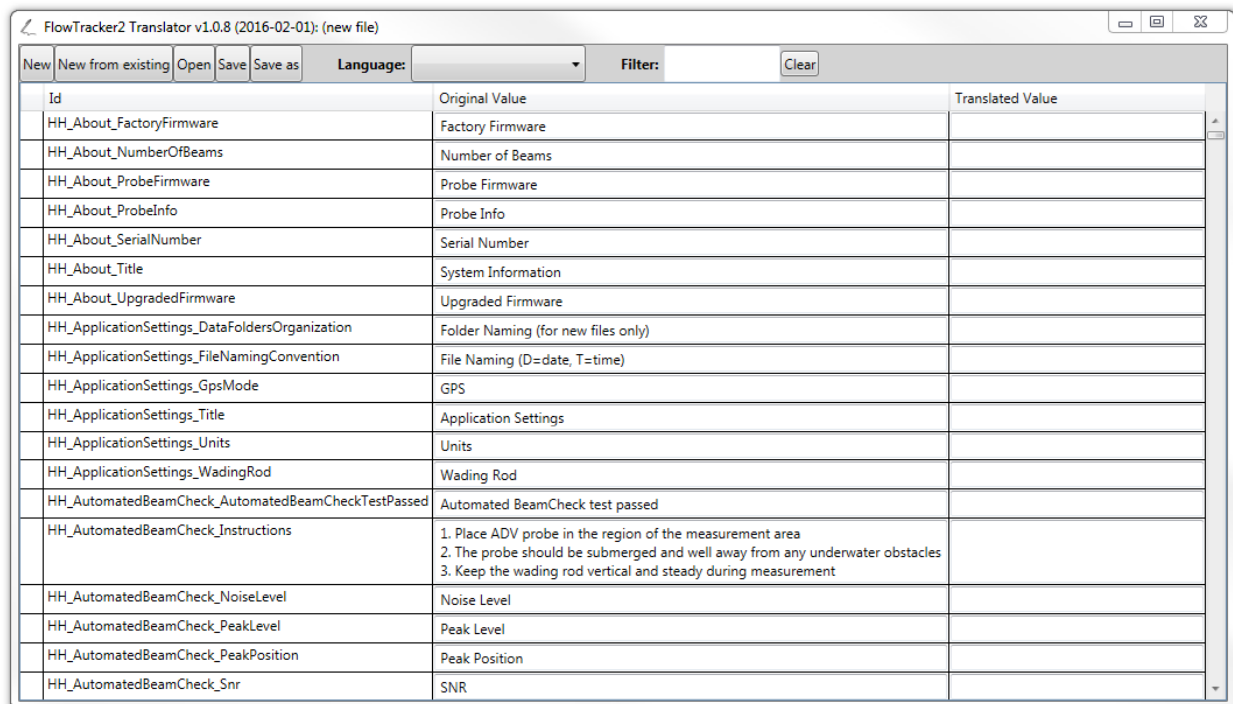

Figure 14:10 Run Translator Dialog

The Run Translator Dialog (Figure 14:10) allows a user to customize a language translation to suit specific purposes or to translate to a language not included in the standard language list. An extensive list of variables used by the software appears under the “Id” column, with its description or association in the “Original Value” column. The user can enter their translated value into the “Translated Value” column. A “Filter” function at the top of the dialog allows users to search for specific terms to be translated.

To save a translation file for future use, first pick a language from the drop-down menu at the top. Then, click the “Save” or “Save As” button, and specify the name of the language file you wish to create. A **.lang** file will be created in the directory of choice.

14.4.3 Import Language File (Utilities > Import Language File)

Once a **.lang** file is created (see previous section), this file can be applied to the software using the Import Language File dialog. You will be prompted to open the **.lang** file that you have created. The FlowTracker2 software will then restart to apply the changes associated with the custom **.lang** file.

14.4.4 New Discharge Template (Utilities > New Discharge Template)

To create a new Discharge Template, press the New Discharge Template button under the Utilities Menu. Choose a template name and destination for the template on your computer. A new template with extension **.ft_template** will be created. To configure an

existing or new template upload to FlowTracker2 Handheld device, please refer to [Uploading and Downloading Templates](#).

14.4.5 New General Template (Utilities > New General Template)

To create a new General Template (template associated with General Mode measurements), follow the same instructions in the previous section for creating a Discharge Template.

14.4.6 Multiple Templates (Utilities > Multiple Templates)

Multiple Templates can be created in the handheld by performing a bulk import of monitoring sites from a CSV file. The steps involved in creating a CSV file and multiple templates are summarized below,

a) Create CSV Template

- i). Open existing template from the “View Data” button,
- ii). Select “Save Template as CSV File” feature,
- iii). Save the CSV file to user defined folder.

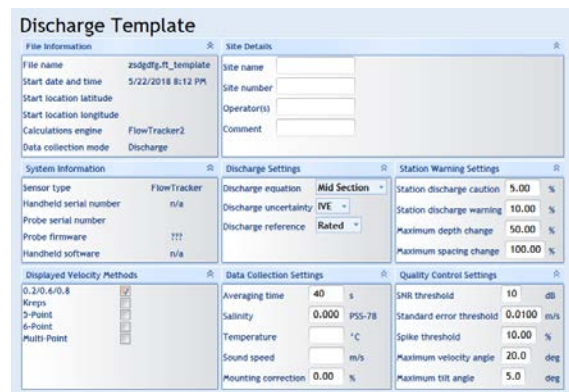

Figure 14:11 Save Template as CSV File

b) Populate Fields in CSV File

- i). The headers supplied in the top row of CSV file define parameters required,
- ii). Each row represents a different monitoring site.

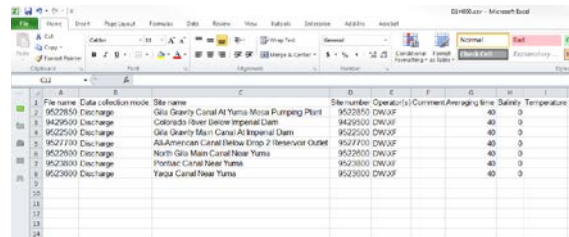

Figure 14:12 CSV File Format

c) Create Multiple Templates

- i). Select the “Multiple Templates” features in “Utilities”,
- ii). Open CSV file created for Multiple Templates,
- iii). Set Input Units of CSV File to Create Template Files dialog box displayed.

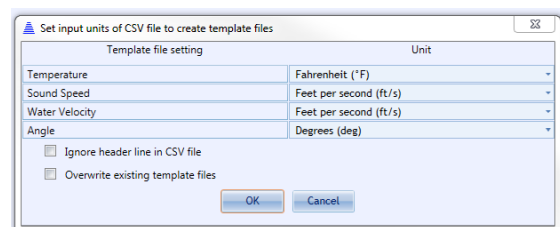

Figure 14:13 Set Input Units of CSV File to Create Template Files

The Set Input Units of CSV File to Create Template Files Dialog ([Figure 14:13](#)) allows a user to define the units of the parameters populated in the CSV file. The dialog box also give the option to “Ignore header lien in CSV file” and “Overwrite existing template files”.

A new template with extension .ft_template will be created for each of the monitoring sites populated in the CSV file. The templates will be copied to the same folder path where the CSV file is located. To configure an existing or new template upload to FlowTracker2 Handheld device, please refer to [Uploading and Downloading Templates](#).

14.5. Connecting to the FlowTracker2 Handheld ADV



The FlowTracker2 Desktop Software is designed to connect to the FlowTracker2 Handheld ADV only. User will not be able to use FlowTracker2 desktop software to connect to an Original FlowTracker Handheld ADV. User will also not be able to use the Original FlowTracker software or SonUtils to connect to the FlowTracker2.

The FlowTracker2 Handheld ADV can connect to your PC in two ways: using a direct **USB to micro-USB connection**, or using your PC’s **Bluetooth radio**. To connect, click on the **Device** button, shown in [Figure 14:14](#). Instructions for each connection type follow in the subsequent sections.

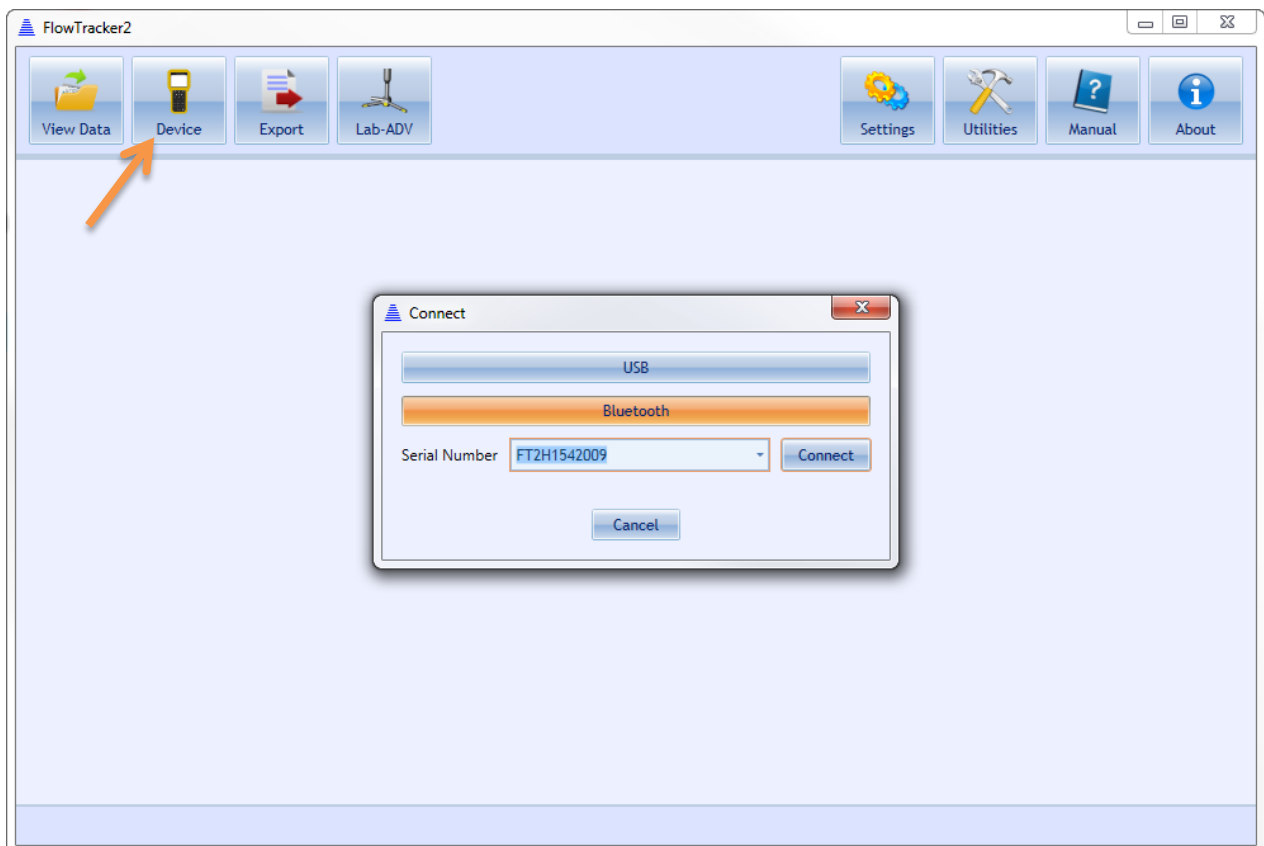

Figure 14:14. Connecting to FlowTracker2

14.5.1 USB Connection (Device > USB)

To connect to the FlowTracker2 Handheld ADV using the **USB to micro-USB connection**,

- Plug the micro-USB connector to the communications connector at the bottom of the Handheld unit (see [Figure 1:1](#)).
- Plug the USB cable end into a USB port of your PC.
- Ensure that you have the battery pack installed in the Handheld device with sufficient battery power, and turn on your FlowTracker2.
- From the main menu, navigate to the Communications button (Left panel of [Figure 14:15](#)) and click the Center Key. The FlowTracker2 will wait for a signal from the PC, showing the screen in the right panel of [Figure 14:15](#).

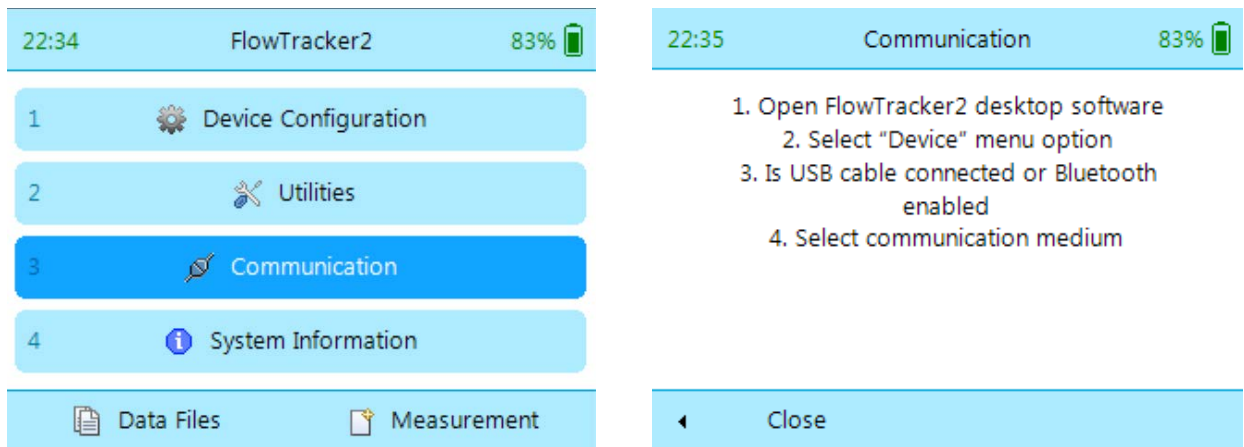

Figure 14:15. Communication dialog

- From the FlowTracker2 Desktop Software, in the Device dialog, click the USB button. The software will attempt to connect automatically with the FlowTracker2.
- Once successfully connected, the FlowTracker2 data files will be listed, as shown in [Figure 14:16](#). The handheld will indicate that it is connected to your computer.

14.5.2 Bluetooth Connection



Do not use your Windows Bluetooth manager to pair the FlowTracker2 device to your computer's Bluetooth radio. The software will perform the pairing automatically.

To connect to the FlowTracker2 using **Bluetooth**,

- Ensure that you have the battery pack installed in the Handheld device with sufficient battery power, and turn on your FlowTracker2.
- From the main menu, navigate to the Communications button (Left panel of [Figure 14:14](#)) and click the Center Key. The FlowTracker2 will wait for a signal from the PC, showing the screen in the right panel of [Figure 14:14](#).

- c) Ensure that your computer Bluetooth radio (wireless communications) is turned on.
- d) Enter the full serial number of your FlowTracker2 device in the Input box that appears (see [Figure 14:16](#)).
- e) Click the Connect button. A dialog will appear with updates on the Bluetooth connection status.
- f) Once successfully connected, the FlowTracker2 data files will be listed, as shown in [Figure 14:17](#). The handheld will indicate that it is connected to your computer.



The FlowTracker2 software will remember different devices after they are first connected using Bluetooth. To remove a device, open the Serial Number drop-down menu and click “remove.”

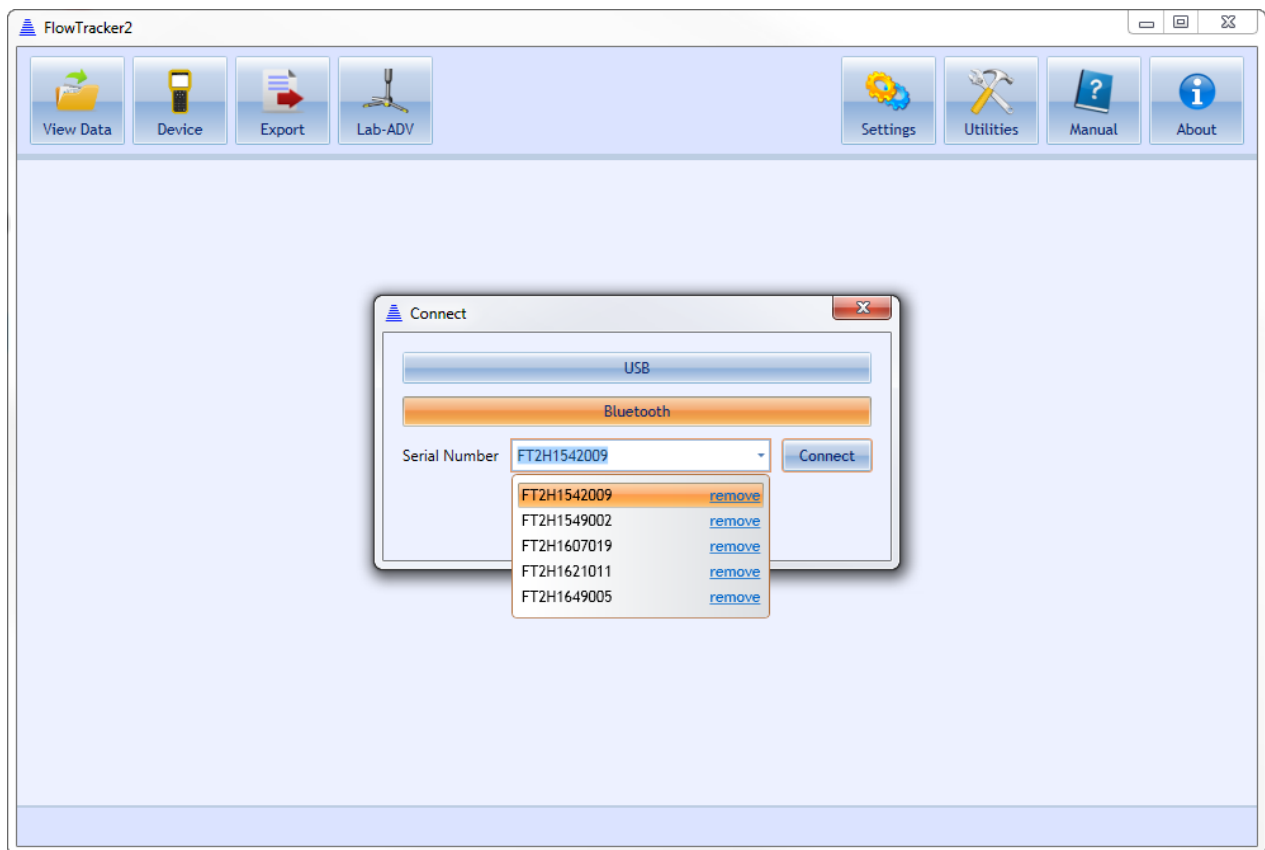

Figure 14:16. Bluetooth Connection Dialog

14.6. Device Menu and Functions

Once connected with the FlowTracker2, there are a number of functions available that allow you to download data and interact with the handheld device. These functions are indicated in [Figure 14:16](#) and are described below.

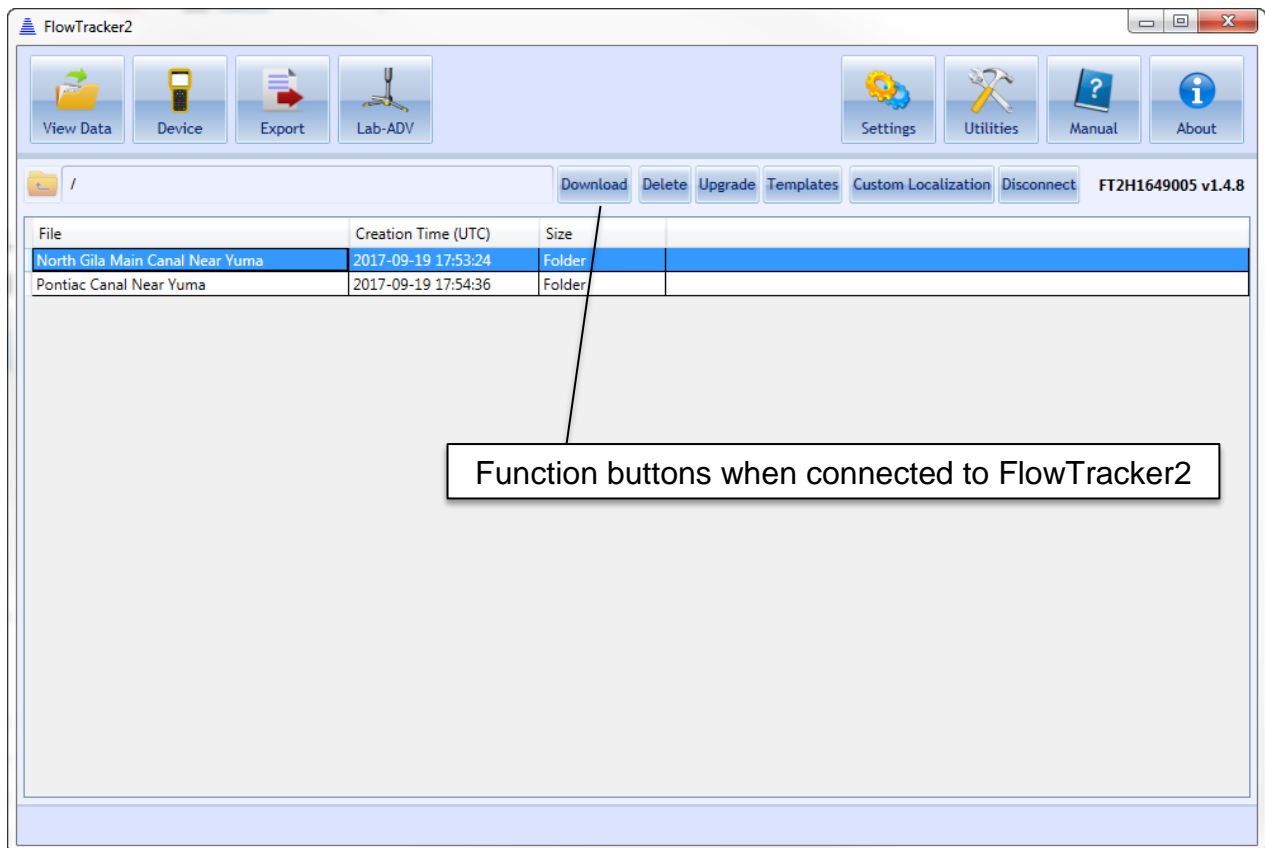

Figure 14:17. Device Menu after successful connection

14.6.1 Download Data Files (Device > [Choose your connection] > Download)

To download data files, you must click on a file or multiple files.

- To select a single file, click on that file.
- To select a range of files, hold the **SHIFT** key and select your files.
- To select multiple specific files, hold the **CTRL** key and select your files. You can also de-select files using the **CTRL** key.

Once the files are selected, the **Download** button will be activated. Click the **Download** button. The Download dialog, shown in [Figure 14:18](#), will appear.

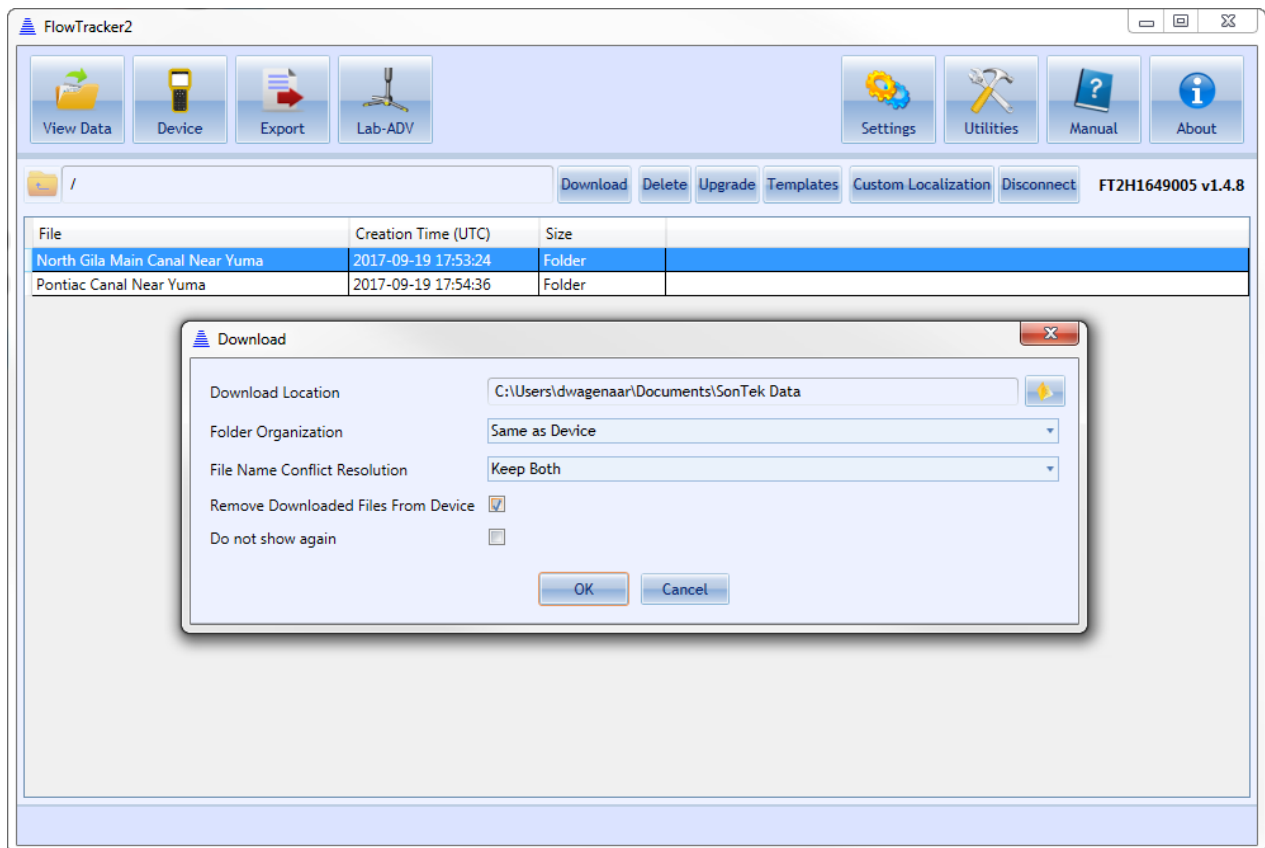

Figure 14:18. Download Data dialog

- a) The **Download Location** can be changed by clicking the folder button on the right.
- b) The **Folder Organization** option dictates with what type of folder structure data files are stored:
 - i). **Same as Device** – Each data file will have its own folder with the same naming convention as on the device.
 - ii). **By Device Serial Number** – files are stored in a folder indicated by the device serial number.
 - iii). **Single Folder** – all files stored in single folder indicated by the Download Location.
- c) The File Name Conflict Resolution provides options when downloading a file from the device with the same file name as one existing in the Download Location directory. The choices are to:
 - i). **Keep Both** – both files placed in same folder and newest file will have name with incrementally growing number extensions (i.e. “_2.ft”, “_3.ft”, etc.).
 - ii). **Skip** – skips downloading duplicate files.
 - iii). **Overwrite** – overwrites existing file on PC with newly downloaded file of same name.

- d) Checking the **Remove Downloaded Files From Device** box will delete any files from the handheld recorder that have been downloaded onto the PC.
- e) Checking the **Do not show again** box will save your downloading preferences, and data will automatically be downloaded according to those preferences when the Download button is pushed. To re-enable the dialog box, see [Show Download Options Dialog](#).

14.6.2 Delete Data files (Device > [Choose your connection] > Delete)

To delete data files from the handheld device, select the files to be removed. A prompt will appear to confirm file deletion.

14.6.3 Upgrading FlowTracker2 Firmware (Device > [Choose your connection] > Upgrade)

Periodic firmware updates will be released. The firmware files will be available from the SonTek website (<http://www.sontek.com>) or by contacting SonTek Technical Support. If you have upgraded your desktop software, but not your firmware, the software will notify you that a firmware upgrade is available upon connection with the FlowTracker2 (shown in [Figure 14:19](#)). The firmware file needs to first be downloaded and saved onto the computer used to connect to the FlowTracker2. The **Upgrade** function will open a dialog to select the FlowTracker2 firmware file. Select the appropriate file and click 'Open' – the firmware upgrade will begin automatically. First, the firmware file will be uploaded to the handheld device. Then, the handheld device will disconnect automatically from the computer, and will perform the upgrade. When the upgrade is complete, the handheld will restart automatically.

Occasional firmware upgrade files may or may not include an upgrade to the FlowTracker2 probe firmware. Because the ADV probe has its own set of electronics, it has its own firmware that may periodically need updating. When the Handheld firmware is upgraded using the software, the probe firmware is not automatically performed until the Handheld queries the probe. This means that when the probe is accessed (to take a measurement, see its firmware version, perform a beam check, etc.), the probe firmware will automatically be updated, and requires no additional steps by the user. The user will see a pop-up on the Handheld software indicating that the probe firmware upgrade is taking place.



Do not manually disconnect or turn off the device during a firmware upgrade process. Doing so will interrupt the firmware upgrade and potentially cause serious corruptions on the handheld device. It is recommended to use the USB direct connection when upgrading firmware to avoid possible wireless connection interruptions.

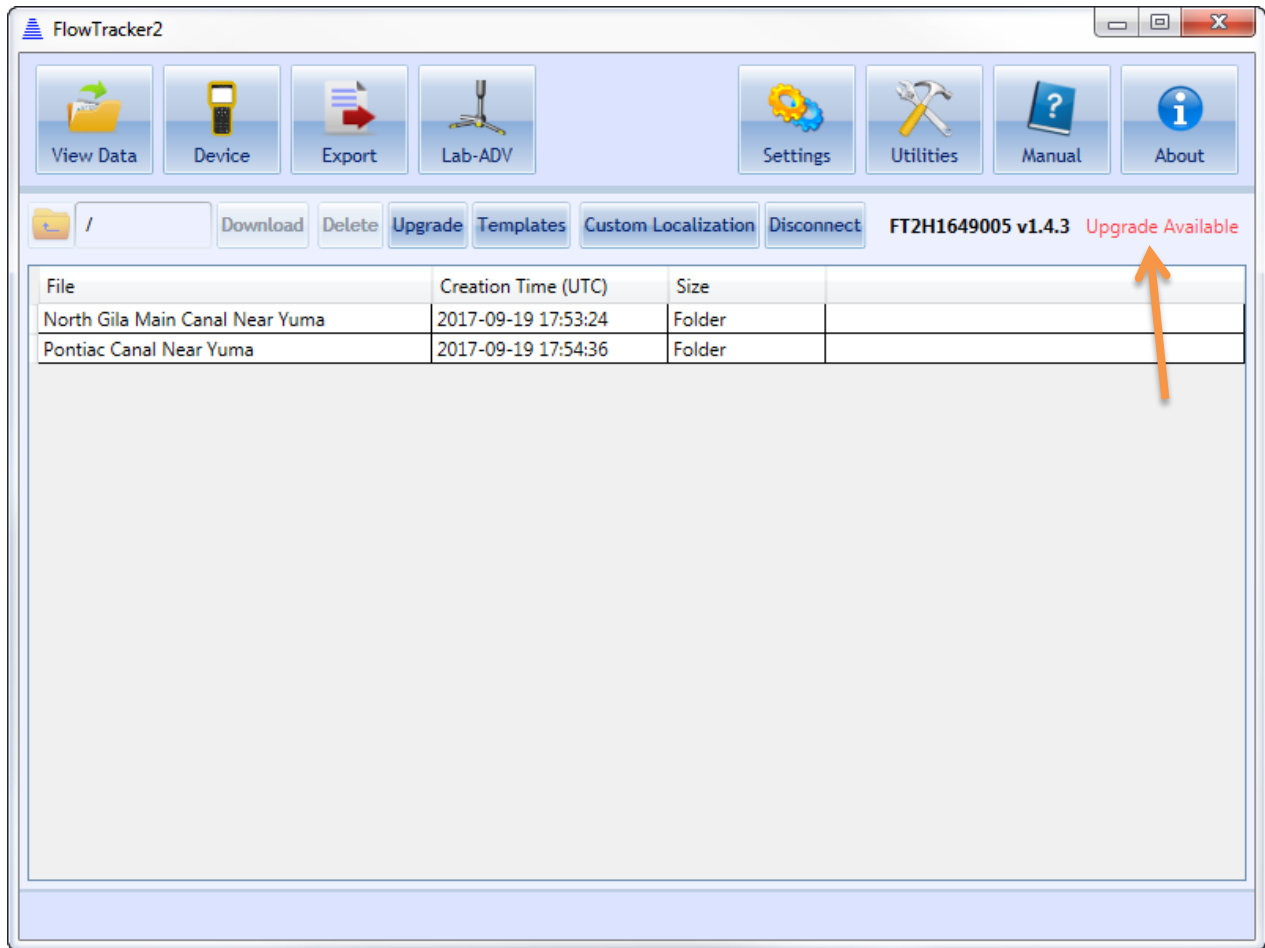

Figure 14:19. Firmware Upgrade Alert

14.6.4 Uploading and Downloading Templates (Device > [Choose your connection] > Templates)

The ability to use templates is a new feature in the FlowTracker2 Handheld ADV operation, allowing the user to easily store and load data that are applicable to multiple measurements (such as site name, site number, operator, etc.). This feature allows faster operation because the user will not need to input certain values for each measurement. Please see [Configuration Templates](#) on how to create and manipulate templates from the FlowTracker2 Handheld device.

To **download** an existing template from the FlowTracker2, click the Templates button after connecting with a unit. The available templates stored on the device will appear. Select the appropriate files, click Download to PC, and choose a destination on your computer to save the files. The template files will be saved with the extension `.ft_template`.

To **upload** an existing template from your computer to the FlowTracker2, click Templates > Upload to Device, and select the appropriate .ft_template file. The template file will be added to the list of templates on your device that appears.

Templates can be either created on the Handheld device and modified on a computer, or created through the desktop software and uploaded to the device. Please refer to [New Discharge Template](#) for instructions on how to create a template file using the software. Please refer to [Opening FlowTracker2 Template Files \(.ft_template\)](#) for instructions on opening and editing template files.

14.6.5 Custom Localization

Custom Localization allows a user to import Language files onto the handheld device. Please see [Run Translator](#) for instructions on creating a Language file (.lang).

14.6.6 Disconnecting the FlowTracker2

To disconnect the FlowTracker2 from the computer, click the **Disconnect** button.

14.7. Opening a Data File

To view FlowTracker data files, click the **View Data** button to turn View Data on. The first time this button is clicked, a dialog will appear to select a file. To open more files, click the **+** tab shown in [Figure 14:20](#). The Open File dialog ([Figure 14:21](#)) will appear. The FlowTracker2 software is capable of opening the following file types:

- FlowTracker File (.ft)
- FlowTracker Beamcheck File (.ft_beamcheck)
- FlowTracker Template File (.ft_template)

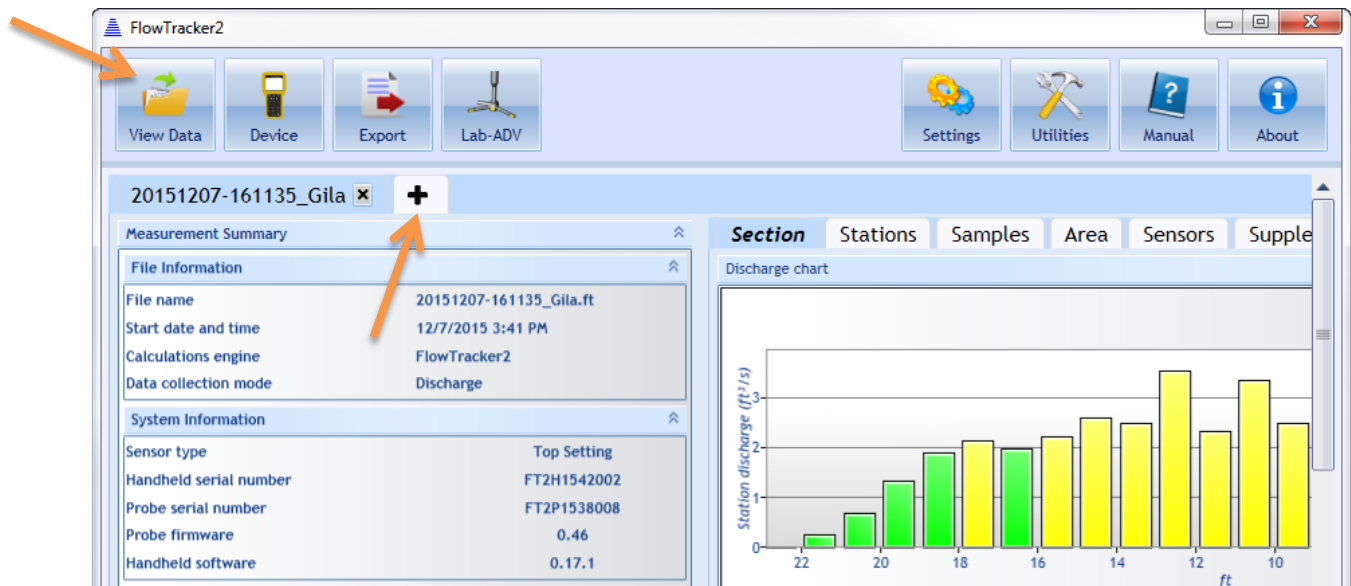

Figure 14:20. + Tab to open additional data files



The FlowTracker2 Desktop software is capable of opening FlowTracker2 (.ft) files only. In order to open files from the Original FlowTracker (.wad), please follow the steps specifically for .wad files in subsequent sections.

14.7.1 Opening FlowTracker2 Handheld ADV Data Files (.ft files)

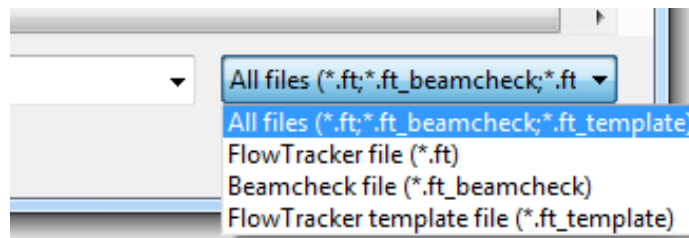

Figure 14:21. Open File Dialog.

The FlowTracker2 .ft file is the main data file that contains your Discharge or General Mode measurement. To open a ft file from the Open File dialog, navigate to the appropriate folder, select “All files” or “FlowTracker file” in the drop-down menu on the lower right, select the appropriate .ft file to be opened from the list populated, and click the **Open** button.

Sample data files are included with the USB that came with your FlowTracker2 package and are located in the “FlowTracker2 Example Data” folder on the USB drive.

14.7.2 Opening FlowTracker2 BeamCheck Files (.ft_beamcheck)



During a measurement, the FlowTracker2 will save BeamCheck information within the .ft file. The FlowTracker2 also has the option of recording a separate BeamCheck which results in a .ft_beamcheck file.

The FlowTracker2 BeamCheck (.ft_beamcheck) file results from a user requesting a BeamCheck to be done separately from a measurement. To open a .ft_beamcheck file, follow the same instructions for opening a .ft file, but select “Beamcheck file (*.ft_beamcheck)” in the drop-down menu, or select an appropriate .ft_beamcheck file from the “All files” drop-down option.

Opening a Beamcheck file produces the screen shown in [Figure 14:22](#). The time stamp on the top of the file dialog corresponds to when the beam check was started, in local time. Handheld information, probe information, beam check statistics, and quality control warnings are displayed in the first row of panels. For each sample, Sample information and statistics are displayed in the second row of panels. A plot of the SNR (dB) against the distance from the ADV receiver is shown at the bottom. To toggle between samples, press the “Previous sample” and “Next sample” buttons. “Show average” will show the average SNR profile over all samples in the beam check file.

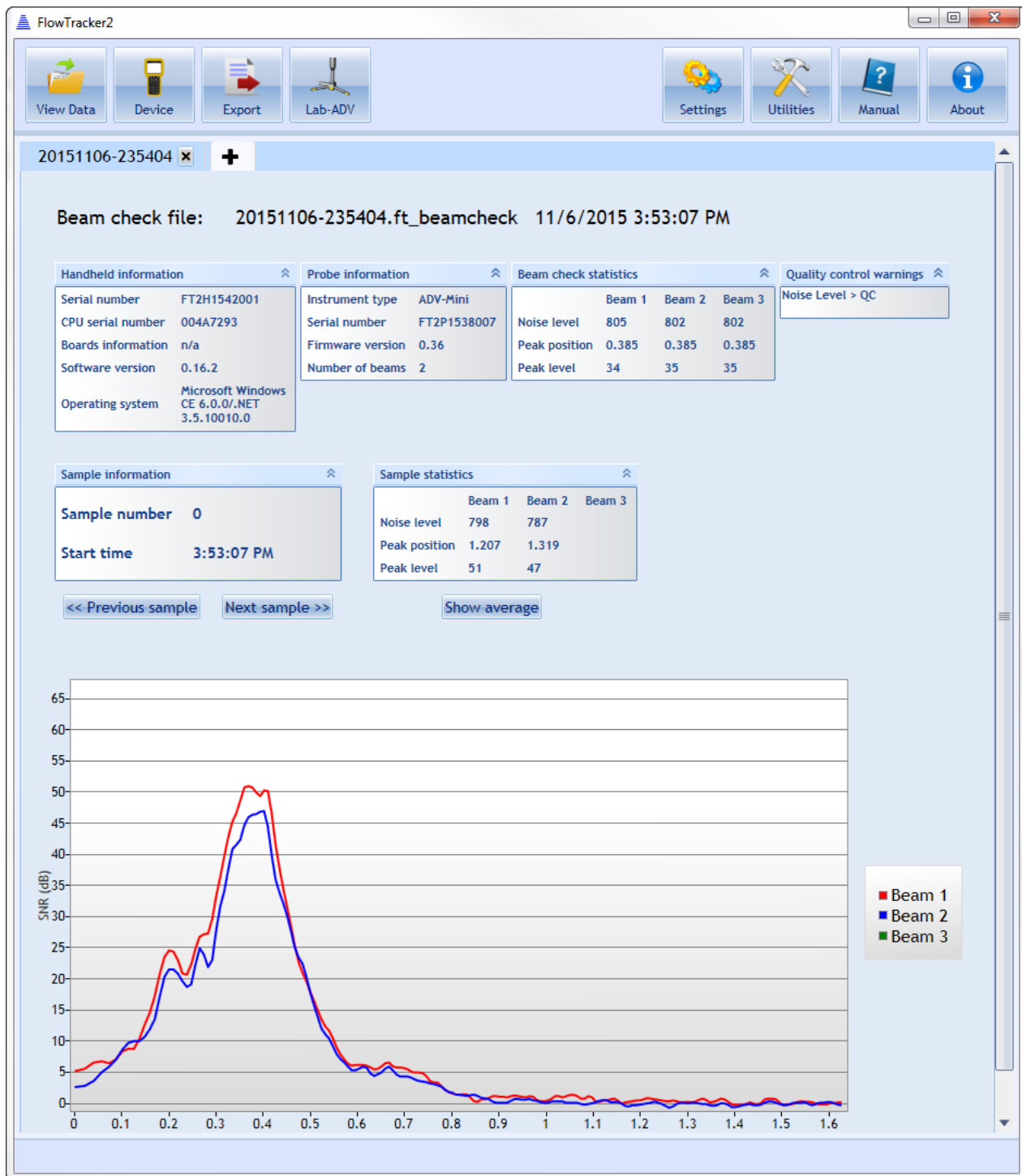

Figure 14:22. Viewing a Beamcheck File

14.7.3 Opening FlowTracker2 Template Files (.ft_template)

The FlowTracker2 software allows you to open and edit template files separately from the Handheld unit. To open a template (.ft_template) file, follow the same instructions for opening a .ft file, but select “FlowTracker template file (*.ft_template)” or select an appropriate .ft_template file from the “All files” drop-down option.

When a Discharge template is opened, the screen shown in [Figure 14:23](#) will appear. Fields that can be edited will show input boxes. When a General Mode template is opened, similar fields to the Discharge template will appear, with the exception that Discharge Settings, Station Warning Settings, and Displayed Velocity Methods fields will not be available. To save changes to the template, click the **Save Template File** button.

The screenshot displays the FlowTracker2 software interface for editing a Discharge Template. The window title is "FlowTracker2" and the active tab is "Gila Main". The main content area is titled "Template File" and contains a "Discharge Template" form. The form is organized into several sections:

- File Information:** File name (Gila Main.ft_template), Start date and time (9/19/2017 6:47 PM), Calculations engine (FlowTracker2), Data collection mode (Discharge).
- Site Details:** Site name, Site number, Operator(s), Comment.
- System Information:** Sensor type (FlowTracker), Handheld serial number (n/a), Probe serial number, Probe firmware (??), Handheld software (n/a).
- Discharge Settings:** Discharge equation (Mid Section), Discharge uncertainty (IVE), Discharge reference (Rated).
- Station Warning Settings:** Station discharge caution (5.00 %), Station discharge warning (10.00 %), Maximum depth change (50.00 %), Maximum spacing change (100.00 %).
- Displayed Velocity Methods:** 0.2/0.6/0.8 (checked), Kreps, 5-Point, 6-Point, Multi-Point.
- Data Collection Settings:** Averaging time (40 s), Salinity (0.000 PSS-78), Temperature, Sound speed, Mounting correction (0.00 %).
- Quality Control Settings:** SNR threshold (10 dB), Standard error threshold (0.0328 ft/s), Spike threshold (10.00 %), Maximum velocity angle (20.0 deg), Maximum tilt angle (5.0 deg).

At the bottom of the form are two buttons: "Save Template as CSV File" and "Save Template File".

Figure 14:23 - Discharge Template

14.7.4 Opening Original FlowTracker Handheld ADV Data Files (.WAD files)

The FlowTracker2 software can import Original FlowTracker Handheld ADV data from either .wad or ASCII files. The Original FlowTracker files are not directly imported and the FlowTracker2 software provides a tool to convert .wad or ASCII files to the .ft format that can be opened using the software. The Original FlowTracker import tool can be accessed under Utilities, shown in [Figure 14:24](#).

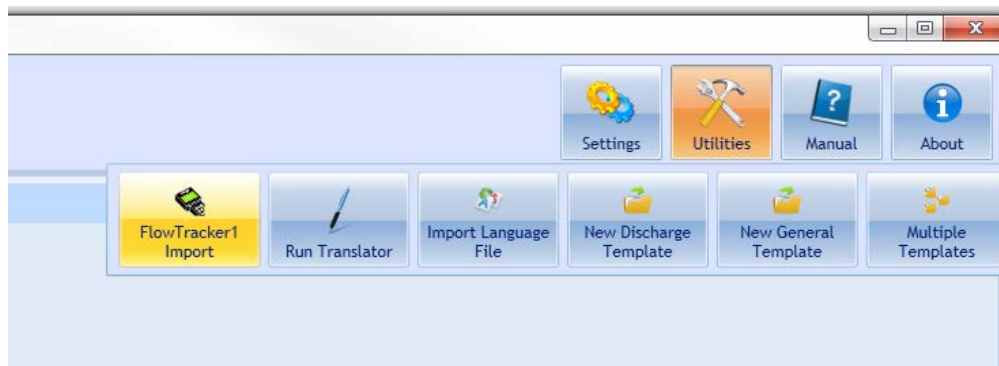

Figure 14:24. Original FlowTracker .wad File Import Tool

The FlowTracker2 software supply two options to import Original FlowTracker data from either the ASCII or WAD files, shown in [Figure 14:24](#).

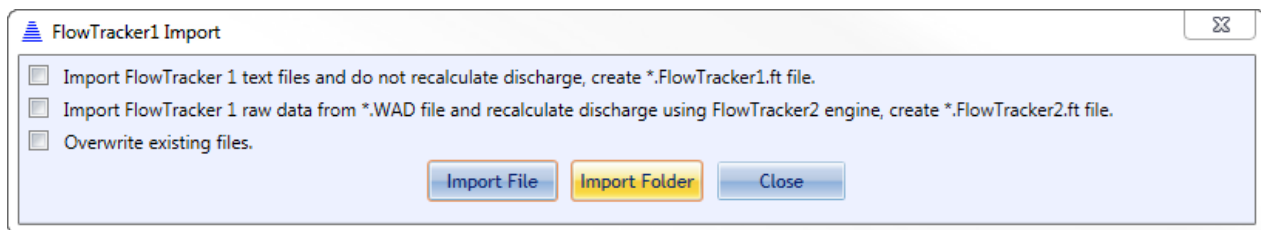

Figure 14:25. FlowTracker1 Import

The criteria associated with each file format import are summarized in [Table 14:2](#). Import of ASCII files will preserve the Original FlowTracker discharge calculations. If any editing is performed in FlowTracker2 software, the Original FlowTracker discharge will be recalculated based on FlowTracker2 Engine.

Table 14-2. Original FlowTracker File Format Import

File Format	Calculation	Engine	Requirement
ASCII	Not Recalculated	Original FlowTracker Engine	The (4) ASCII and WAD files must be present in the same folder. The .DIS, .DAT, .CTL, and .SUM ASCII files are exported using the Original FlowTracker desktop software
WAD	Recalculated	FlowTracker2 Engine	The WAD file must be present in the folder.



ASCII: The “Put Headers on ASCII Files” option in the Original FlowTracker desktop software must be selected before the ASCII files are created. This will ensure that header information is placed at the top of the ASCII file.



WAD: Only WAD files generated post 2006 firmware can be converted.

The import process shown in [Figure 14:25](#). FlowTracker1 Import allows the user to import a single or multiple Original FlowTracker files at a time,

- **Import File** – Select the .wad file you would like to convert. The ASCII exports must be associated with this file, or you will receive an error message during the data import. The resulting file converted will have the same file name, but the .wad extension will be replaced with **.FlowTracker1.ft**.
- **Import Folder** – Select the folder containing multiple .wad files you would like to convert. The tool will look within subfolders recursively to convert all .wad files with associated ASCII exports. If the ASCII exports do not exist in the same folder(s) as the .wad files, an error message will appear. The resulting files converted will have the same file name, but the .wad extension will be replaced with **.FlowTracker1.ft**.

The **.FlowTracker1.ft** file can now be opened in similar method as the FlowTracker2, .ft file.

14.8. Overview of View Data Options

When a FlowTracker data file is opened, three panes will appear ([Figure 14:26](#)): the Measurement Summary pane, the main viewing pane (including tabs offering various views), and the Settings pane.



Figure 14:26. Layout of Data Viewing Window and Section Tab

14.8.1 Measurement Summary Pane

The Measurement Summary Pane values are summarized in [Table 14:3](#).

Table 14-3. Measurement Summary Pane

Category	Value	Description
File Information	File name	File name
	Start date and time	Start date and time of measurement
	Calculations engine	Identifies which calculation algorithm was used: Original FlowTracker (FlowTracker1) or FlowTracker2
	Data collection mode	Discharge or General Mode
System Information	Sensor type	Top setting, Universal, or Ice (not available with Original FlowTracker)
	Handheld serial number	Handheld device serial number
	Probe serial number	Probe serial number (not available with Original FlowTracker)
	Probe firmware	Probe firmware
	Handheld software	Handheld software version
Discharge Summary	# Stations	Number of stations measured
	Mean depth	Mean depth over all stations
	Mean velocity	Mean velocity over all velocity measurements
	Mean SNR	Mean Signal to Noise Ratio over all velocity measurements
	Mean temp	Mean temperature over all measurements
	Avg interval	Probe averaging interval per sample (in seconds)
	Total width	Total transect width
	Total area	Total transect area
	Total discharge	Total discharge
Discharge Uncertainty	Category	ISO or IVE
	Accuracy	Accuracy (%)
	Depth	Uncertainty on depth (%)
	Velocity	Uncertainty on velocity (%)
	Width	Uncertainty on width (%)
	Method	Uncertainty on method used (%)
	# Stations	Uncertainty on number of stations (%)

Category	Value	Description
	Overall	Total uncertainty
View Controls	Chart size + / Chart size -	Increase or decrease size of all plots within software
	Reset all	Reset size of all plots to default

14.8.2 Main Viewing Pane

The main viewing pane consists of seven tabular views in Discharge Mode, and 6 tabs in General Mode. The contents of each tab are described below.

14.8.2.1 Section

The Section plots ([Figure 14:26](#)) are shown with respect to station location. The left bank is always shown at the left regardless of whether measurements were taken starting at the left or right bank. Plots available are:

- **Station discharge** – discharge per station
- **Velocity** – mean velocity per sample. Blue vectors indicate the mean velocity measured (in the X-direction with respect to the ADV probe). If multiple points exist, the blue vector represents the vertical average. The red vector(s) indicate actual velocity measured at each point, incorporating the Y-component of flow to indicate the skew ness of the flow with respect to the X-axis.
- **Depth** – depth measured at each station (from user input at each station). The actual measurement depths are indicated by dots. Hovering over the dots produces a pop-up showing the actual depth those measurements were made.

14.8.2.2 Stations

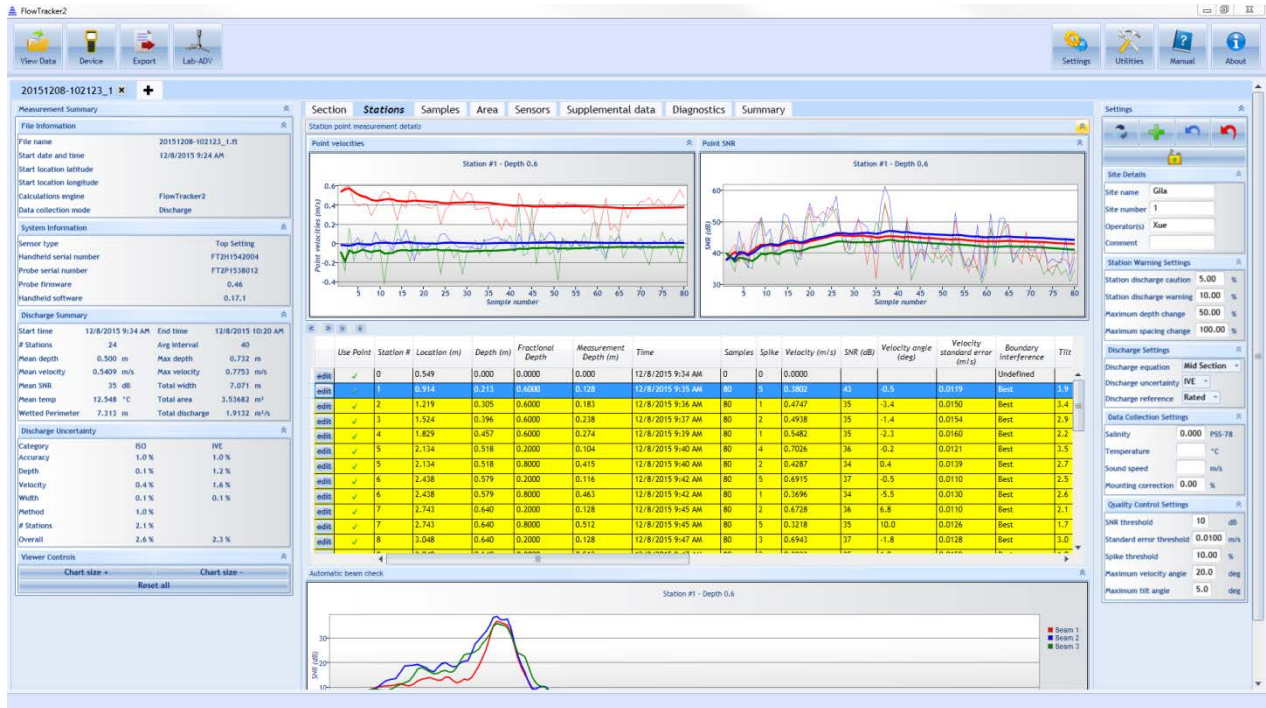

Figure 14:27. Layout of Stations Tab.

The Stations tab (Figure 14:27) shows detailed data for each station. The station in active view is highlighted in blue. Clicking on a different station line will highlight that station, and its available data will be displayed. Fields in the Station tab can be edited. For details on how to edit various parameters, please refer to Section 14.9 . Plots/data available are:

- **Velocities** – X,Y, (and Z, if using a 3D probe) velocities measured during a station point measurement spanning chosen sampling period,
- **SNR** – mean beam SNR measured during a station point measurement spanning chosen sampling period,
- **Station information** – Station information summary. Values displayed are described in Table 14:4. The number of rows and columns that are viewable can be changed by using the four arrows that appear above the station information summary table in the software.

The continuous lines displayed in the graphics are defined under the following categories,

- Thin** continuous line represents the one second raw data,
- Thick** continuous line represents moving average of the one second raw data.

Table 14-4: Station Information Values Available

Edit	Orig. FT	FT2	Value	Description
------	----------	-----	-------	-------------

Edit	Orig. FT	FT2	Value	Description
✓	✓	✓	Use Point	Indicates whether the station is used in the discharge calculation. This feature can be edited.
	✓	✓	Station #	Station number
✓	✓	✓	Location	Station location along tag line
✓	✓	✓	Depth	Depth at each station (from user input during measurement)
	✓	✓	Fractional Depth	Fractional depth
	✓	✓	Measurement Depth	Actual measurement depth
	✓	✓	Time	Time at start of station
	✓	✓	Samples	Number of samples in station
	✓	✓	Spike	Number of spikes during measurement period
✓	✓	✓	Velocity	Measured mean velocity
	✓	✓	SNR	Mean SNR (all beams)
	✓	✓	Velocity angle	Mean velocity angle with respect to FlowTracker probe X axis
	✓	✓	Velocity standard error	Velocity standard error
	✓	✓	Boundary interference	Boundary interference quality parameter (Best, Good, Fair, Poor)
		✓	Tilt	Mean Tilt
✓	✓	✓	Correction factor	User entered correction factor
	✓	✓	Width	Width of section
	✓	✓	Area	Area of section
	✓	✓	Mean velocity	Mean velocity calculated by dividing discharge by area
	✓	✓	Station discharge	Station discharge
✓	✓	✓	Temperature	Mean station temperature
	✓	✓	Warnings	Warnings associated with each station. Stations with warnings are highlighted in yellow.
✓	✓	✓	Comment	Comments from user input during measurement
✓	✓	✓	Station type	Station type (OpenWater, LeftBank, RightBank, IslandEdge, Ice)
✓	✓	✓	Velocity method	Velocity method used
		✓	GPS Latitude	GPS Latitude if GPS fix was recorded
		✓	GPS Longitude	GPS Longitude if GPS fix was recorded
		✓	Altitude	GPS Altitude if GPS fix was recorded
		✓	Number of	GPS number of satellites if GPS fix

Edit	Orig. FT	FT2	Value	Description
			satellites	was recorded
		✓	Fix quality	GPS fix quality if GPS fix was recorded
		✓	HDOP	HDOP if GPS fix was recorded

- **Automatic beam check** – For each station, the mean beam check data is displayed below the station information summary table. The SNR for each ADV beam is plotted with distance (“Range”) from the sample volume.

14.8.2.3 Samples

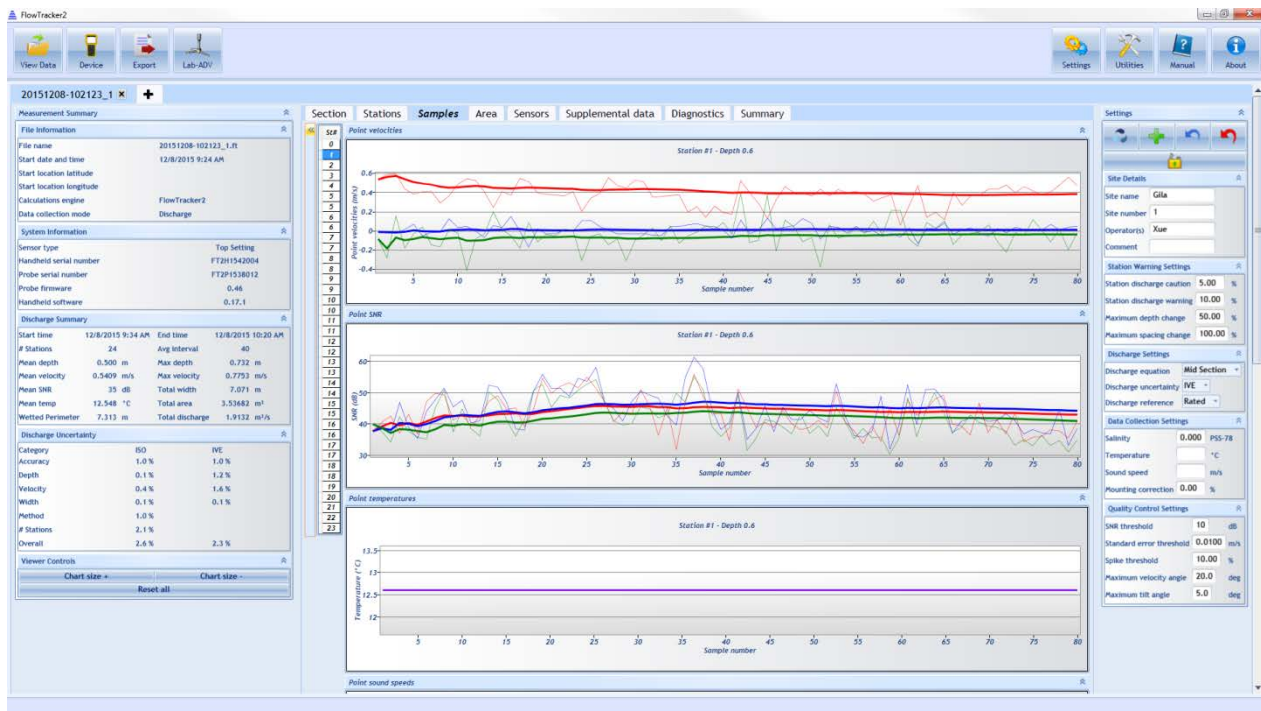

Figure 14:28. Layout of Samples

The Samples tab (Figure 14:28) contains the following plots. The point measurement selection can be performed by selecting the appropriate station number in the “Station Number” column on the left of plots. All point measurements at the same station will be allocated the same station number. The header of each plot distinguishes between the specific station number and point measurement.

- **Velocities** – X,Y, (and Z, if using a 3D probe) velocities measured during a station point measurement spanning chosen sampling period,
- **SNR** – beam SNR measured during a station point measurement spanning chosen sampling period,
- **Temperature** – Temperature measured during a station point measurement spanning chosen sampling period,

- **Pressure (Pressure Sensor)** – Pressure measured during a station point measurement spanning chosen sampling period (only available ,
- **Sound Speed** – Sound Speed calculated during a station point measurement spanning chosen sampling period,
- **Voltage** – Voltage measured during a station point measurement spanning chosen sampling period,
- **Pitch** – Pitch measured during a station point measurement spanning chosen sampling period,
- **Roll** – Roll measured during a station point measurement spanning chosen sampling period.

The continuous lines displayed in the graphics are defined under the following categories,

- Thin** continuous line represents the one second raw data,
- Thick** continuous line represents moving average of the one second raw data.

14.8.2.4 Area



Figure 14:29. Layout of Area Tab

The Area tab (Figure 14:29) contains the following plots:

- **Area** – the Area plotted with respect to the tagline location of each station

- **Width** – the transect Width plotted with respect to the tagline location of each station
- **Velocity angle** – the angle of the flow with respect to the X-axis of the ADV probe plotted with respect to the tagline location of each station. The mean is calculated over all station samples. In the case of multiple point measurements per station, a value will appear for each point measurements at a given station location.

14.8.2.5 Sensors

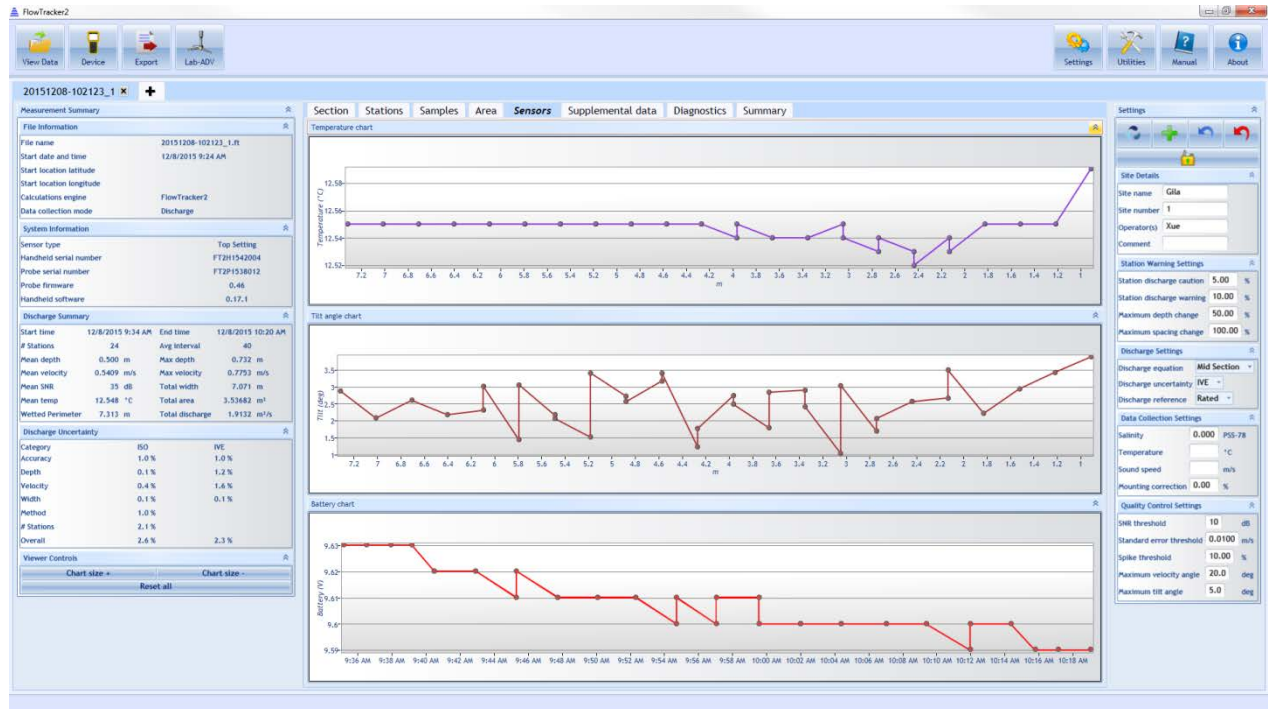

Figure 14:30. Layout of Sensors Tab

The Sensors tab (Figure 14:30) contains the following plots:

- **Temperature** – the mean temperature recorded during each station plotted with respect to the tagline location of each station. In the case of multiple point measurements per station, a value will appear for each point measurements at a given station location.
- **Tilt** – the mean tilt recorded during each station plotted with respect to the tagline location of each station. In the case of multiple point measurements per station, a value will appear for each point measurements at a given station location.
- **Battery** - the mean battery voltage recorded during each station plotted with respect to the tagline location of each station. In the case of multiple point measurements per station, a value will appear for each point measurements at a given station location.

14.8.2.6 Supplemental Data

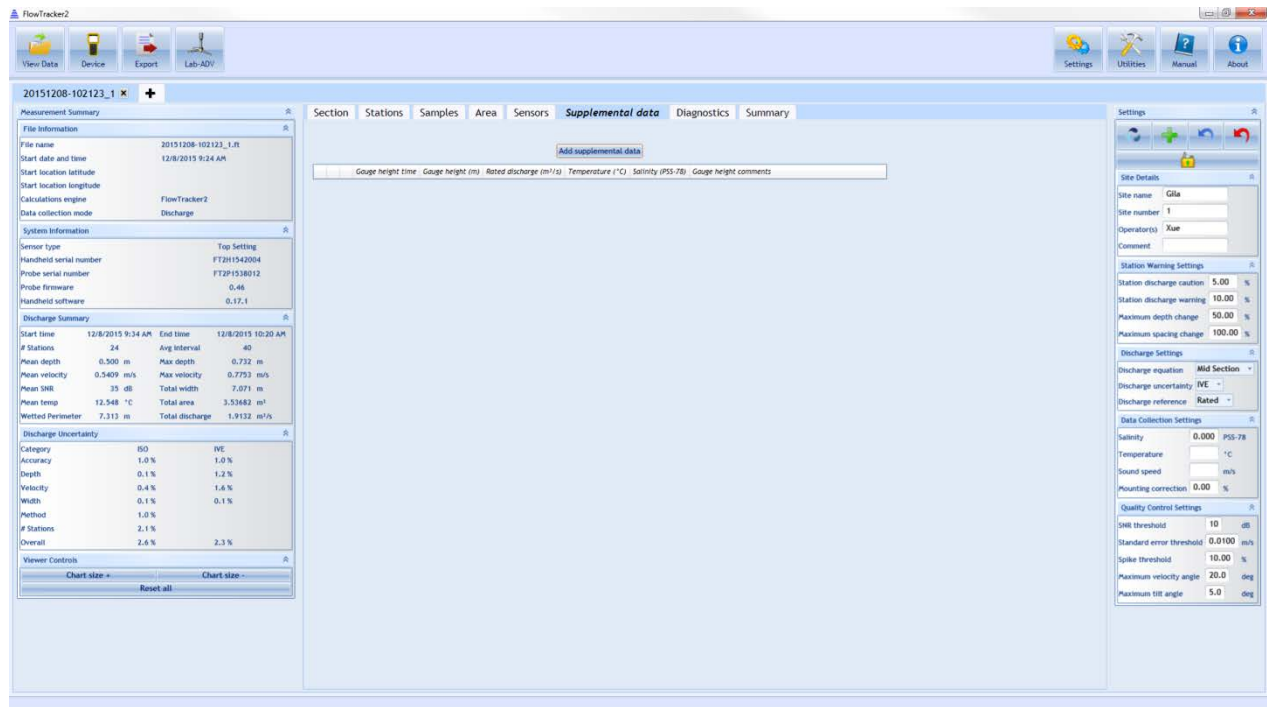

Figure 14:31. Layout of Supplemental Data Tab

Any supplemental data added during the measurement will appear in the Supplemental Data tab (Figure 14:31). Multiple supplemental data entries can be available during a measurement. Supplemental data values are the following:

- **Gauge height time** – time at which gauge height is taken
- **Gauge height** – gauge height read from external source
- **Rated discharge** – rated discharge acquired from external source
- **Temperature** – temperature acquired from external source
- **Salinity** – salinity acquired from external source
- **Gauge height comments** – any comments associated with gauge height or rated discharge reading



Supplemental data can be added after the measurement is collected in Post-Processing. Please refer to Section 14.9 for post-processing instructions.

14.8.2.7 Diagnostics



Figure 14:32. Layout of Diagnostics Tab

The Diagnostics tab (Figure 14:32) shows data pertaining to the quality of the measurement. The following plots are available:

- **SNR** – the mean SNR at the ADV sample volume over all samples and all beams at each station. In the case of multiple point measurements per station, a value will appear for each point measurements at a given station location. In the case of multiple point measurements per station, a value will appear for each point measurements at a given station location.
- **Spike** – the number of spikes that were detected over all samples at each station. Spikes are removed from the velocity measurement. In the case of multiple point measurements per station, a value will appear for each point measurements at a given station location.
- **Velocity standard error** – the velocity standard error calculated over all samples at each station. In the case of multiple point measurements per station, a value will appear for each point measurements at a given station location.
- **Samples** – the number of samples collected per station

14.8.2.8 Summary

The Summary tab shows a comprehensive overview of the measurement. The information presented in the other tabs and panes are summarized in this tab. Please refer to other sections for descriptions of the specific values presented in this tab.

One feature in the Summary tab is the ability to export the measurement to a PDF file. Please see [Export Discharge Summary to PDF](#) for details on how to use this function.

14.8.3 Settings Pane

The Settings pane contains general information about the site, the measurement, and user input values. Much of this information is editable – please refer to [Post-Processing FlowTracker Measurements](#) regarding how to edit these values. The information presented in the Settings Pane is summarized in [Table 14:5](#).

Table 14-5. Summary of Settings Pane Values

Category	Edit	Value	Description
Site Details	✓	Site Name	Site name
	✓	Site Number	Site number
	✓	Operator(s)	Operators(s)
	✓	Comment	Comments
Station Warning Settings	✓	Maximum station discharge	Maximum % discharge at each station after which a warning will be issued
	✓	Maximum depth change	Maximum % depth change between consecutive stations after which a warning will be issued
	✓	Maximum spacing change	Maximum % spacing change between consecutive stations after which a warning will be issued
Discharge Settings	✓	Discharge equation	Discharge equation used in discharge calculation (MidSection, MeanSection, Japanese)
	✓	Discharge uncertainty	Discharge uncertainty calculation used to calculate uncertainty (Iso, Ive, None)
	✓	Discharge reference	Discharge reference (Measured, Rated)
Data Collection Settings	✓	Salinity	Salinity used in velocity measurement
	✓	Temperature	Temperature used in velocity measurement. If left blank,

Category	Edit	Value	Description
			will use measured temperature in velocity calculation. If value is entered, this value will be used.
	✓	Sound speed	Sound speed used in velocity measurement. If left blank, will use measured temperature and entered salinity in calculation of sound speed used in velocity calculation. If value is entered, this value will be used.
	✓	Mounting correction	Mounting correction (%) applied to velocity value.
Quality Control Settings	✓	SNR threshold	SNR threshold (dB). If mean SNR at sample volume is below this value, a warning will be issued.
	✓	Standard error threshold	Standard error threshold (in velocity units). If standard error over all samples at each station exceeds this threshold, a warning will be issued.
	✓	Spike threshold	Spike threshold (in counts). If number of spikes at a station exceeds this value, a warning will be issued.
	✓	Maximum velocity angle	Maximum velocity angle (in degrees). If mean angle of flow with respect to ADV X-axis exceeds this value at a station, a warning will be issued.
	✓	Maximum tilt angle	Maximum tilt angle (in degrees). If mean tilt at a station exceeds this value, a warning will be issued.

14.9. Post-Processing FlowTracker Measurements

A powerful new feature in the FlowTracker2 now allows the user to edit most values associated with a measurement after the measurement is taken. This section provides instructions on the post-processing ability of the FlowTracker2 software.



Measurements taken with the Original FlowTracker Handheld ADV can also be edited with the FlowTracker2 software.

14.9.1 Enable Editing

14.9.1.1 FlowTracker2 .ft File Editing

By default, any measurement taken with the FlowTracker2 will have editing enabled. The editing pane appears in the top right corner of the software, shown in [Figure 14:33](#).

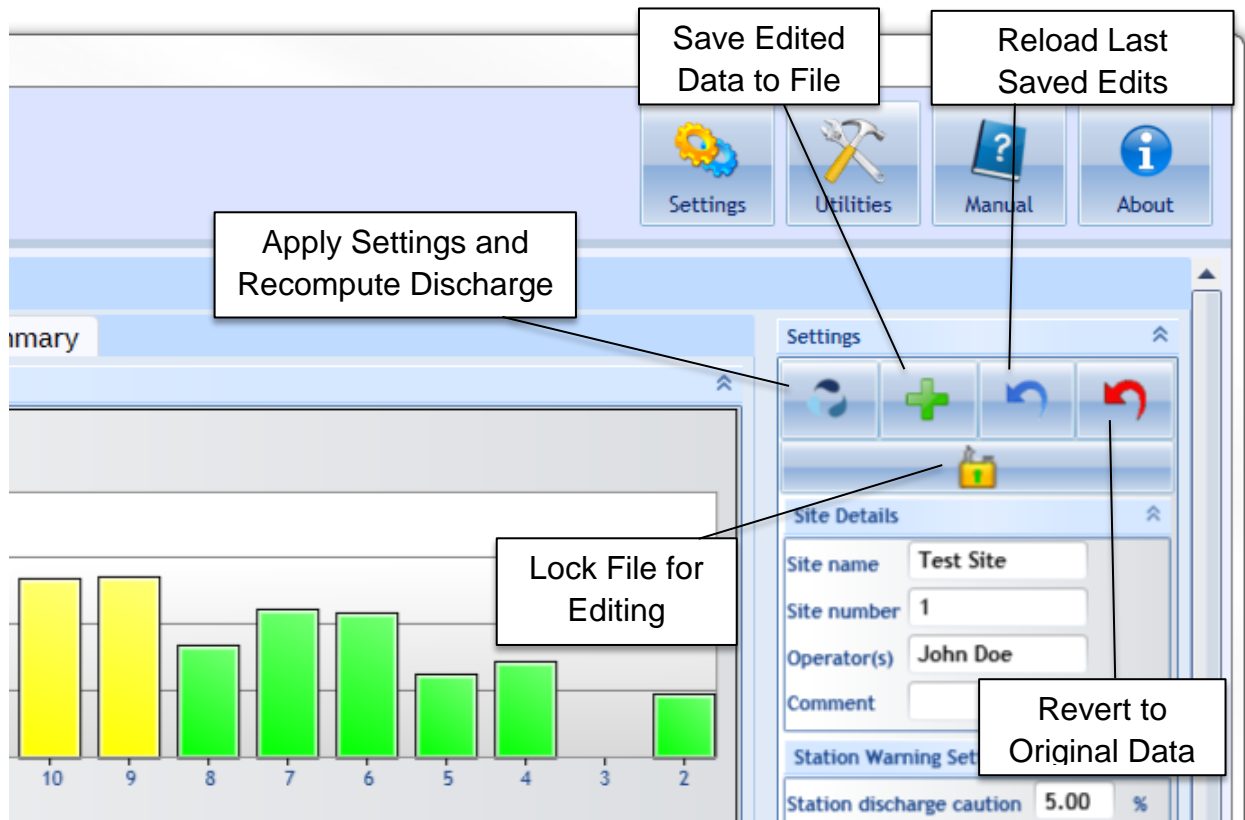

Figure 14:33. FlowTracker 2 Editing Buttons

Functions include:

- **Apply Settings and Recompute Discharge** – after any changes in the Settings Pane (right pane), hitting this button will apply those changes and recalculate discharge.

- **Save Edited Data to File** – after hitting the Apply Settings and Recompute Discharge button, changes will appear in the values displayed in the software, but these changes will not be saved to a file unless the Save Edited Data to File is pressed. A file containing edits will be created in the same folder where the .ft file resides with a “_edited” extension. Once this file is created, opening the .ft file will open the edited file showing the last saved edits.
- **Reload Last Saved Edits** – after performing multiple edits that are not saved, this button is used to revert back to the last saved edits.
- **Revert to Original Data** – reverts to the original .ft file that was downloaded from the FlowTracker2 Handheld unit. The original .ft file will always be preserved regardless of new edits saved.
- **Lock File for Editing** – enabling the feature will prevent any changes to the original measurement file or edited data during post processing. If changes are required to the measurement file or edited data set, the Lock File feature needs to be disabled.

14.9.1.2 Original FlowTracker .wad File Editing



The editing of Original FlowTracker data (.wad files converted to .OriginalFlowTracker1.ft) in FlowTracker2 Desktop Software is not enabled in this software version. The Lock File feature will be enabled (Locked) when opening .OriginalFlowTracker1.ft files, preventing any changes to the Original FlowTracker data.

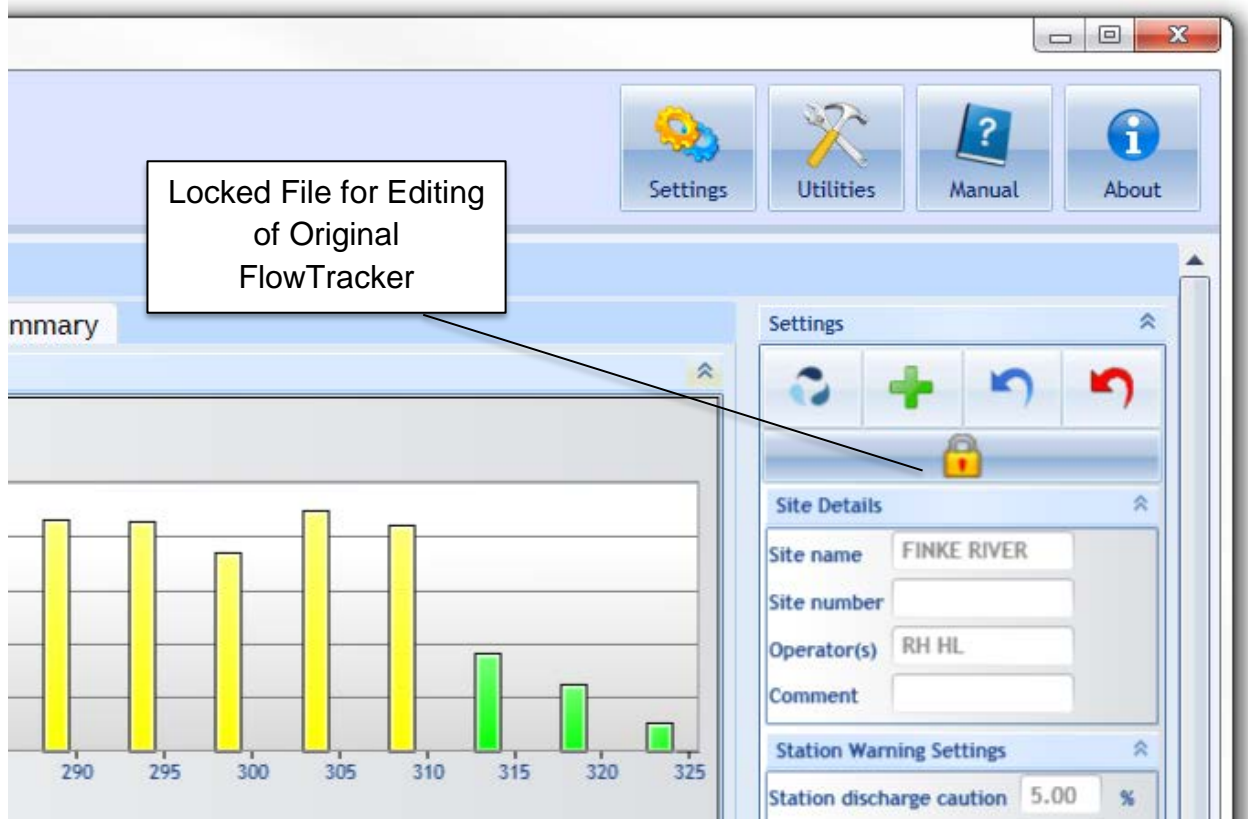

Figure 14:34. Original FlowTracker Editing

14.9.2 Editing through the Settings Pane

The values in the Settings Pane are summarized in [Table 14:5](#). All of these values can be edited. To edit, type in the appropriate changes in the input boxes and press **the Apply Settings and Recompute Discharge** button. Changes will update all necessary parameters displayed in all panes and tabs in the software data view. As shown in [Figure 14:35](#), changed values will appear in the appropriate panes, with their original value included in square brackets.

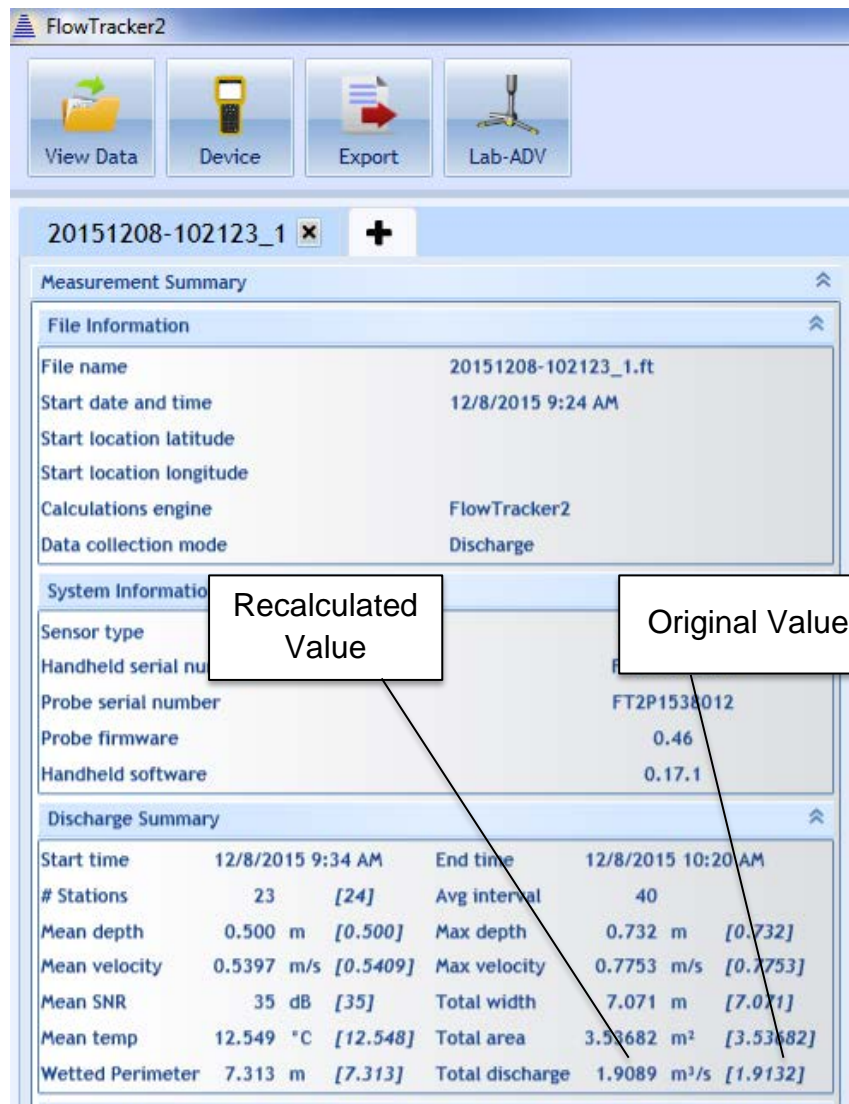

Figure 14:35. Edited Values Updated

14.9.3 Editing by Station

To edit values associated with individual stations within a measurement, first go to the Stations tab. The editable values associated with each station are indicated in [Table 14:4](#). Identify the station you wish to edit, and press the Edit button on the left of that station line, shown in [Figure 14:36](#).

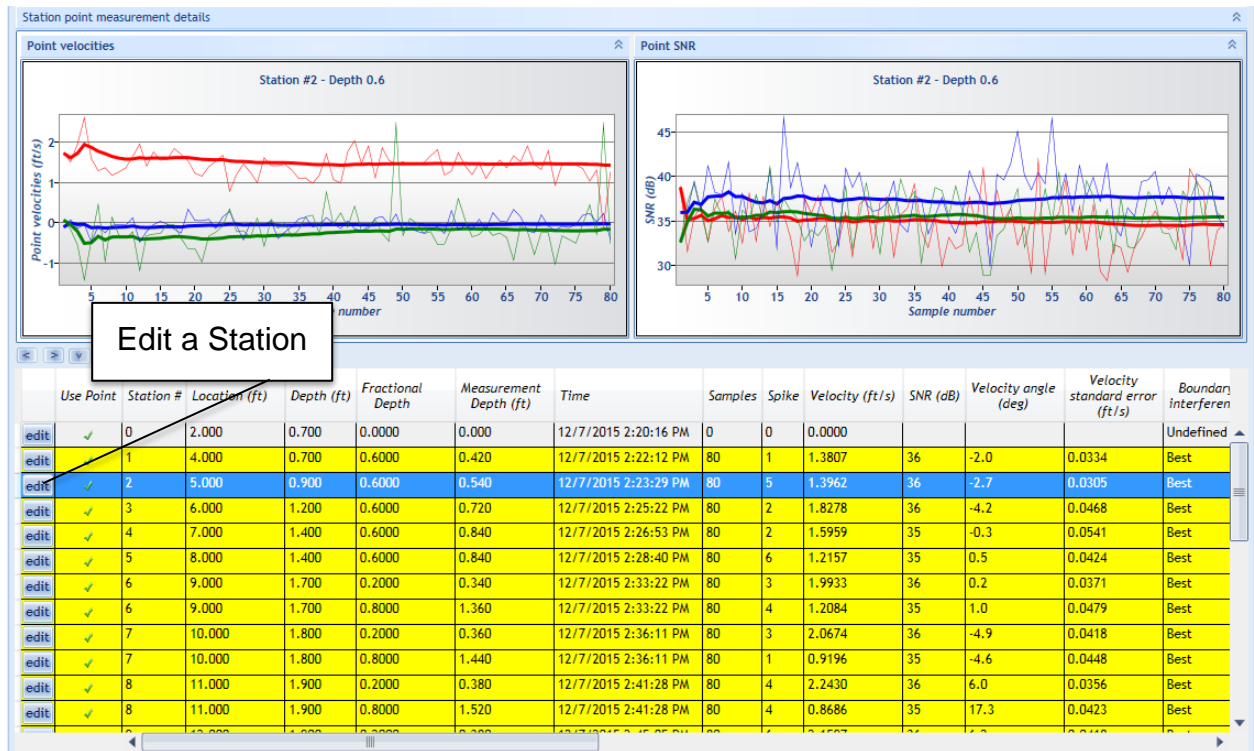

Figure 14:36. Edit by Station

Edit point measurement data

Currently editing data point at Station # 2

Time: 12/7/2015 2:23:29 PM

GPS Latitude:

GPS Longitude:

Station type: **Open Water**

Velocity method: **0.6**

Location (ft): [1.524]

Depth (ft): [0.274]

Correction factor:

Comment:

Figure 14:37. Station Editing Dialog

A pop-up editing dialog will appear when the **Edit** button is pressed, shown in [Figure 14:37](#). Within this dialog, the following items can be edited:

- **GPS Latitude** – GPS latitude if known from external source
- **GPS Longitude** – GPS longitude if known from external source
- **Station Type** – Change station type (LeftBank, RightBank, IslandEdge, OpenWater, Ice). Please note: when changing station types, there are some station type combinations that will result in an error and the software will be unable to compute discharge. For example, inputting two Left Bank station types for the section will result in an error. Please refer to your discharge measurement method guide for specific rules regarding what station types are valid for your measurement.
- **Velocity Method (enter Manual Velocity or None)** – the option exists to enter a manual velocity if it is known at the station and not measured by the ADV. To enter a manual velocity, click the **Change** button and select the “Enter Velocity” option, and hit **Accept**. A new input box will appear in the main dialog to enter a manual velocity value. To select **None** for the Velocity Method, select the “None” option, and hit **Accept**.
- **Location** – Change the location at which the station was taken. Please note: if location does not satisfy the **Maximum Spacing Change** criteria set in the Settings Pane, a warning will appear.
- **Depth** – Change the water depth at the station. Please note: if the depth does not satisfy the **Maximum Depth Change** criteria set in the Settings Pane, a warning will appear.
- **Correction Factor** – Change the correction factor applied to the velocity value. The correction factor is a fraction ranging from [-1:1].
- **Comment** – Change or add a comment associated with station
- **Remove Measurement** – Removing a station removes it from being used in the discharge calculation. Please note: some rules apply to what types of stations can be removed, and are specific to the velocity method used. For example, if the original measurement were a 0.2/0.8 measurement, removing the 0.2 measurement will result in an automatic removal of the 0.8 measurement. If a 0.2/0.6/0.8 measurement is taken, removing the 0.6 measurement will result in removing the 0.6 measurement only, as a 0.2/0.8 is still a valid measurement type. However, for this 0.2/0.6/0.8 measurement, if the 0.2 measurement is

removed, all three measurements associated with this station will be removed (0.2, 0.6, and 0.8). Please consult the rules specific to each measurement type.

- **Revert to Original** – Revert to original values associated with the station when the data file was downloaded from the FlowTracker unit.

After any changes to these editable values, click the **Apply Changes** button. Discharge will be recalculated and new values will be appearing in the appropriate areas.

14.9.4 Editing Supplemental Data

Supplemental data can be added or edited after the measurement is taken and the file is closed in the handheld device. To add or edit supplemental data, first navigate to the Supplemental Data tab ([Figure 14:31](#)). To edit existing supplemental data, simply double click on the field you wish to edit, and enter in a new value. To add a line of supplemental data, click the Add Supplemental Data button. To add additional lines of supplemental data, use the green up/down arrows to add rows above/below the current line, respectively.

14.10. Data Export and File Formats

The FlowTracker2 data can be exported from the FlowTracker2 desktop software in either PDF or ASCII format. The FlowTracker2 measurement file created on the handheld is JSON format and contains all the raw data and measurement results.

14.10.1 Export Discharge Summary to PDF

To export the Discharge Summary to PDF, navigate to the Summary tab and click the **Save PDF of Summary** button. A PDF will be produced and opened using a PDF viewer the user has installed on the computer. An example of a discharge summary is shown in [Figure 14:38](#). The user can then choose to save or print the PDF file.

Discharge Measurement Summary

Site name: Gila
 Site number: 1
 Operator(s): JRM
 File name: 20151208-102123_1.R
 Comment:

Start time: 12/8/2015 9:34 AM
 End time: 12/8/2015 10:20 AM
 Start location latitude: -
 Start location longitude: -
 Calculations system: -

Sensor type: Via Surface
 Headfield serial number: FT2=142204
 Probe serial number: FT2P120121
 Probe firmware: 0.46
 Headfield software: 3.1.1.1

Stations: 24
 Avg interval (s): 40
 Total discharge (m³/s): 1.9132

Total width (m): 7.071
 Total area (m²): 3.3262
 Wetted Perimeter (m): 7.313

Mean Silt (dB): 35
 Mean depth (m): 0.500
 Mean velocity (m/s): 0.5409

Mean temp (°C): 12.940
 Max depth (m): 0.732
 Max velocity (m/s): 0.7792

Discharge Measurement: Category: 0.00%, 0.00%
 Accuracy: 0.00%, 0.00%
 Depth: 0.12%, 0.12%
 Velocity: 0.40%, 0.40%
 Width: 0.11%, 0.11%
 Wetted: 0.40%, 0.40%
 # Stations: 2.50%, 2.50%
 Overall: -

Discharge Measurement: Discharge uncertainty: 0.00%
 Discharge reference: 0.00%
 Data Collection Method: 0.00% PDS-70
 Temperature: 0.00%
 Speed sensor: 0.00%
 Headfield correction: 0.00%
 Summary overview: No changes were made to this file. Quality control warnings: -

5/22/2018 1:26:28 PM

Discharge Measurement Summary

Site name: Gila
 Site number: 1
 Operator(s): JRM
 File name: 20151208-102123_1.R
 Comment:

Measurement results:

Stn	Time	Depth (m)	Velocity (m/s)	Width (m)	Area (m²)	Flow (m³/s)	Temp (°C)	Silt (dB)
1	12/8/2015 9:34:00	0.500	0.5409	0.294	0.147	0.078	12.94	35
2	12/8/2015 9:34:40	0.500	0.5409	0.294	0.147	0.078	12.94	35
3	12/8/2015 9:35:20	0.500	0.5409	0.294	0.147	0.078	12.94	35
4	12/8/2015 9:36:00	0.500	0.5409	0.294	0.147	0.078	12.94	35
5	12/8/2015 9:36:40	0.500	0.5409	0.294	0.147	0.078	12.94	35
6	12/8/2015 9:37:20	0.500	0.5409	0.294	0.147	0.078	12.94	35
7	12/8/2015 9:38:00	0.500	0.5409	0.294	0.147	0.078	12.94	35
8	12/8/2015 9:38:40	0.500	0.5409	0.294	0.147	0.078	12.94	35
9	12/8/2015 9:39:20	0.500	0.5409	0.294	0.147	0.078	12.94	35
10	12/8/2015 9:40:00	0.500	0.5409	0.294	0.147	0.078	12.94	35
11	12/8/2015 9:40:40	0.500	0.5409	0.294	0.147	0.078	12.94	35
12	12/8/2015 9:41:20	0.500	0.5409	0.294	0.147	0.078	12.94	35
13	12/8/2015 9:42:00	0.500	0.5409	0.294	0.147	0.078	12.94	35
14	12/8/2015 9:42:40	0.500	0.5409	0.294	0.147	0.078	12.94	35
15	12/8/2015 9:43:20	0.500	0.5409	0.294	0.147	0.078	12.94	35
16	12/8/2015 9:44:00	0.500	0.5409	0.294	0.147	0.078	12.94	35
17	12/8/2015 9:44:40	0.500	0.5409	0.294	0.147	0.078	12.94	35
18	12/8/2015 9:45:20	0.500	0.5409	0.294	0.147	0.078	12.94	35
19	12/8/2015 9:46:00	0.500	0.5409	0.294	0.147	0.078	12.94	35
20	12/8/2015 9:46:40	0.500	0.5409	0.294	0.147	0.078	12.94	35
21	12/8/2015 9:47:20	0.500	0.5409	0.294	0.147	0.078	12.94	35
22	12/8/2015 9:48:00	0.500	0.5409	0.294	0.147	0.078	12.94	35
23	12/8/2015 9:48:40	0.500	0.5409	0.294	0.147	0.078	12.94	35
24	12/8/2015 9:49:20	0.500	0.5409	0.294	0.147	0.078	12.94	35

Quality Control Settings:

- Maximum depth change: 50.00%
- Maximum opening change: 100.00%
- Gate threshold: 10.00%
- Minimum error threshold: 0.000 m/s
- Maximum velocity angle: 20.0 deg
- Maximum Silt angle: 5.0 deg

Quality control results:

Stn	Time	Depth (m)	Velocity (m/s)	Width (m)	Area (m²)	Flow (m³/s)	Temp (°C)	Silt (dB)	Message
1	12/8/2015 9:34:00	0.500	0.5409	0.294	0.147	0.078	12.94	35	OK
2	12/8/2015 9:34:40	0.500	0.5409	0.294	0.147	0.078	12.94	35	OK
3	12/8/2015 9:35:20	0.500	0.5409	0.294	0.147	0.078	12.94	35	OK
4	12/8/2015 9:36:00	0.500	0.5409	0.294	0.147	0.078	12.94	35	OK
5	12/8/2015 9:36:40	0.500	0.5409	0.294	0.147	0.078	12.94	35	OK
6	12/8/2015 9:37:20	0.500	0.5409	0.294	0.147	0.078	12.94	35	OK
7	12/8/2015 9:38:00	0.500	0.5409	0.294	0.147	0.078	12.94	35	OK
8	12/8/2015 9:38:40	0.500	0.5409	0.294	0.147	0.078	12.94	35	OK
9	12/8/2015 9:39:20	0.500	0.5409	0.294	0.147	0.078	12.94	35	OK
10	12/8/2015 9:40:00	0.500	0.5409	0.294	0.147	0.078	12.94	35	OK
11	12/8/2015 9:40:40	0.500	0.5409	0.294	0.147	0.078	12.94	35	OK
12	12/8/2015 9:41:20	0.500	0.5409	0.294	0.147	0.078	12.94	35	OK
13	12/8/2015 9:42:00	0.500	0.5409	0.294	0.147	0.078	12.94	35	OK
14	12/8/2015 9:42:40	0.500	0.5409	0.294	0.147	0.078	12.94	35	OK
15	12/8/2015 9:43:20	0.500	0.5409	0.294	0.147	0.078	12.94	35	OK
16	12/8/2015 9:44:00	0.500	0.5409	0.294	0.147	0.078	12.94	35	OK
17	12/8/2015 9:44:40	0.500	0.5409	0.294	0.147	0.078	12.94	35	OK
18	12/8/2015 9:45:20	0.500	0.5409	0.294	0.147	0.078	12.94	35	OK
19	12/8/2015 9:46:00	0.500	0.5409	0.294	0.147	0.078	12.94	35	OK
20	12/8/2015 9:46:40	0.500	0.5409	0.294	0.147	0.078	12.94	35	OK
21	12/8/2015 9:47:20	0.500	0.5409	0.294	0.147	0.078	12.94	35	OK
22	12/8/2015 9:48:00	0.500	0.5409	0.294	0.147	0.078	12.94	35	OK
23	12/8/2015 9:48:40	0.500	0.5409	0.294	0.147	0.078	12.94	35	OK
24	12/8/2015 9:49:20	0.500	0.5409	0.294	0.147	0.078	12.94	35	OK

5/22/2018 1:26:28 PM

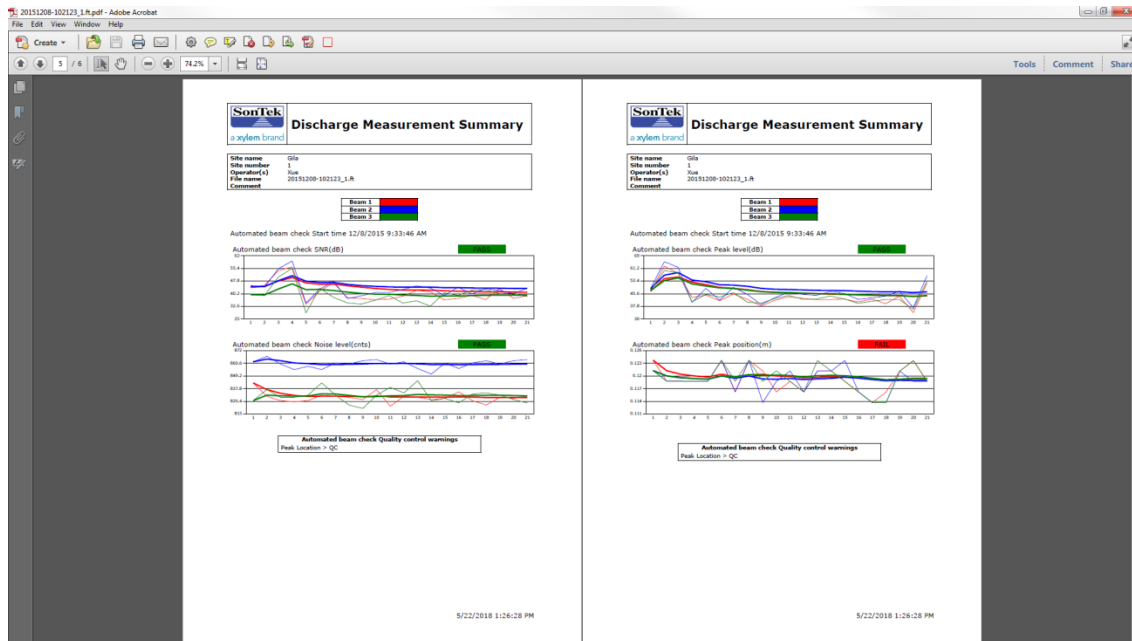

Figure 14:38. PDF Discharge Summary File

14.10.2 Export Files to ASCII

To export .ft files to ASCII format readable by text editors and spreadsheet software (Microsoft Excel, Word, etc.), click the Export button, shown in Figure 14:39.

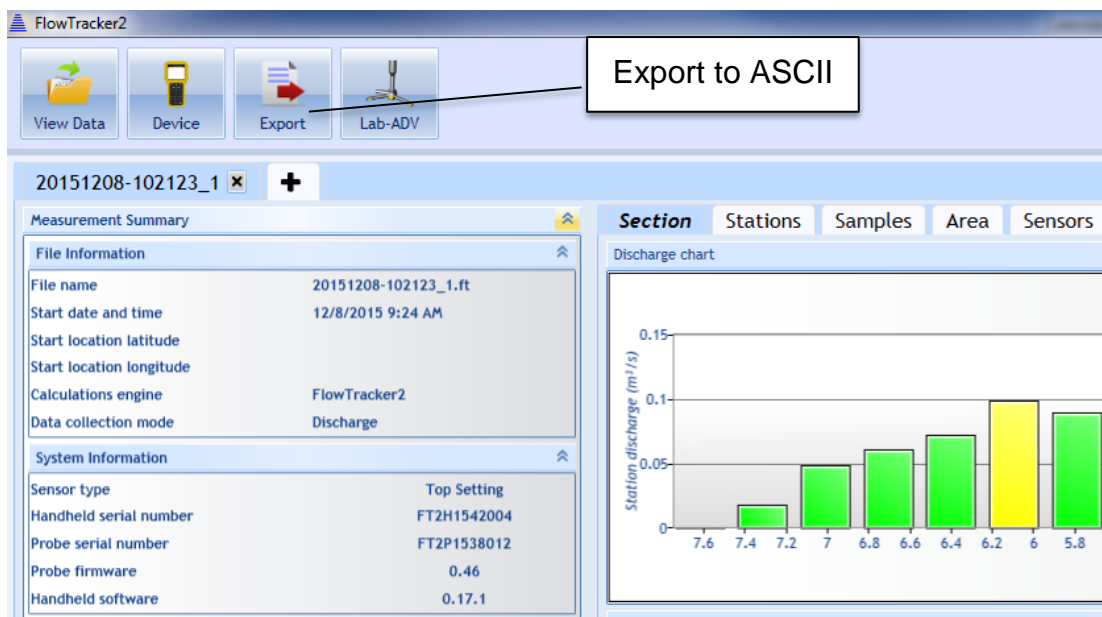

Figure 14:39. Export to ASCII Button

A dialog will appear with the options to Show Headers and Export in English Language. The export function will not automatically export the data you have opened for viewing. Instead, a dialog will appear to select the .ft file you wish to export, and following this, you will select a folder to where the export will save the ASCII files. Four ASCII files will

be created in the selected folder. The contents and format of the ASCII files is summarized in [FlowTracker2 CSV Output](#).

14.10.3 Matlab Tools for JSON files

Although the FlowTracker2 software does not have a specific Matlab export, a number of Matlab tools exist to parse and convert JSON format files to Matlab-readable format, and are readily available through various third-party websites. If help is needed in using Matlab to read the FlowTracker .ft files into Matlab, please contact SonTek (support@sontek.com).

Section 15. FlowTracker2 Lab-ADV

15.1. Lab-ADV Software Feature

The Lab-ADV feature is designed to work in conjunction with a Windows based Computer or Tablet and a FlowTracker2 ADV probe assembly. A [Power and Communication Cable](#) is required to connect the FlowTracker2 probe assembly to the PC or Tablet. The Lab-ADV feature will enable users to perform the following functions

- **Collect** FlowTracker Data at different sampling rates,
- **Generate** CSV file of measured data,
- **Perform** Beam Check before measurement,
- **Upgrade** firmware FlowTracker2 probe,



A license file is required to enable the Lab-ADV feature for a FlowTracker2 probe assembly, where the license is specific to the probe assembly and is based on its serial number. Each probe assembly that will be used with the desktop software Lab-ADV feature will require the purchase of a license.

The Lab-ADV feature can be accessed from the main menu of the FlowTracker2 Desktop Software shown in [Figure 15:1](#).

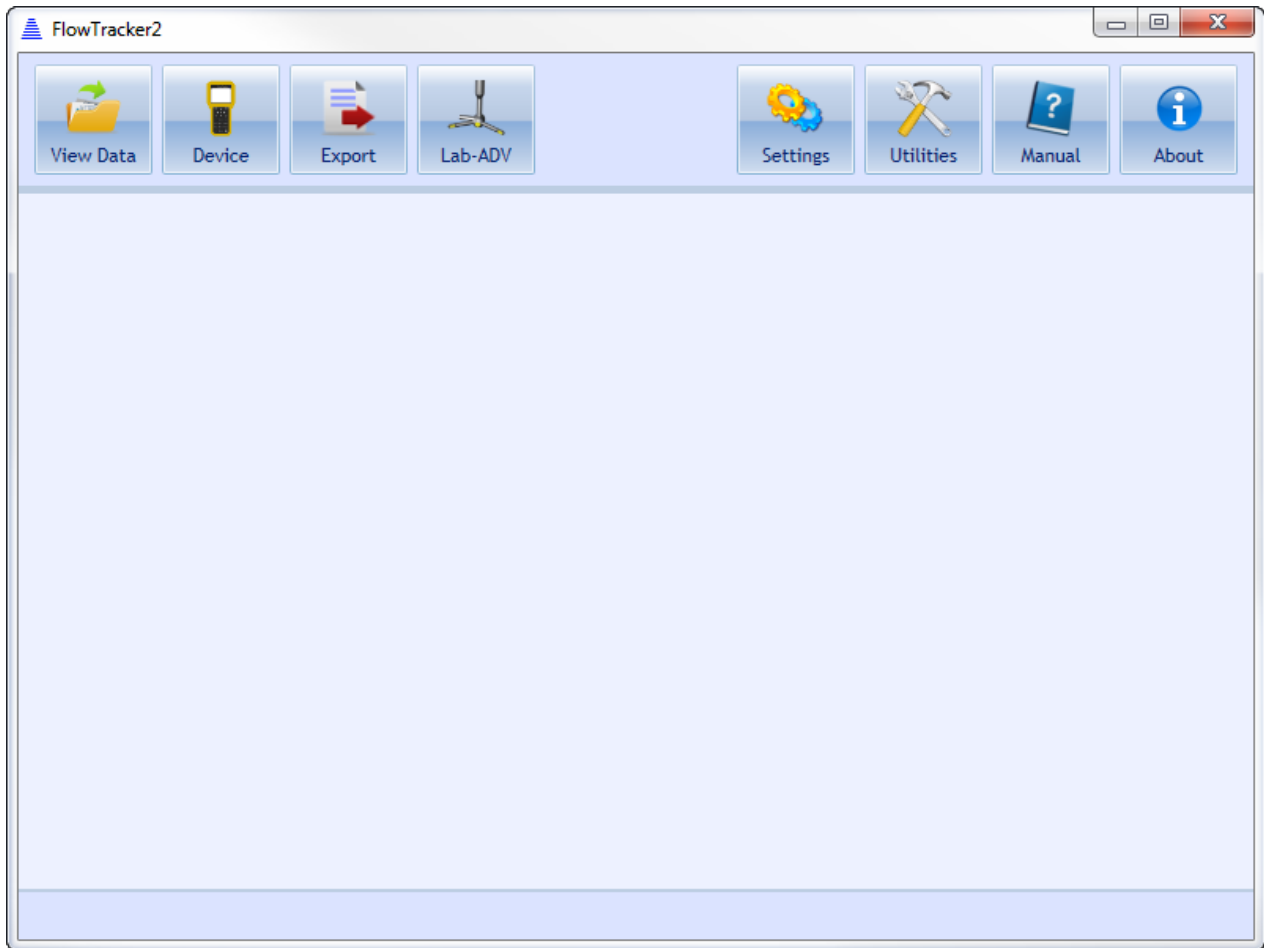

Figure 15:1 – Lab-ADV Feature of FlowTracker2 Desktop Software

15.2. Enable Lab-ADV feature



A license file is required to enable the Lab-ADV feature in a FlowTracker2 probe assembly, where the license is specific to the probe assembly and is based on its serial number. Each probe assembly that will be used with the desktop software Lab-ADV feature will require the purchase of a license.

The Lab-ADV feature is enabled by uploading the license file into the FlowTracker2 Desktop Software. The upload of the license file can be performed from the Settings menu under the General tab, shown in [Figure 15:2](#).

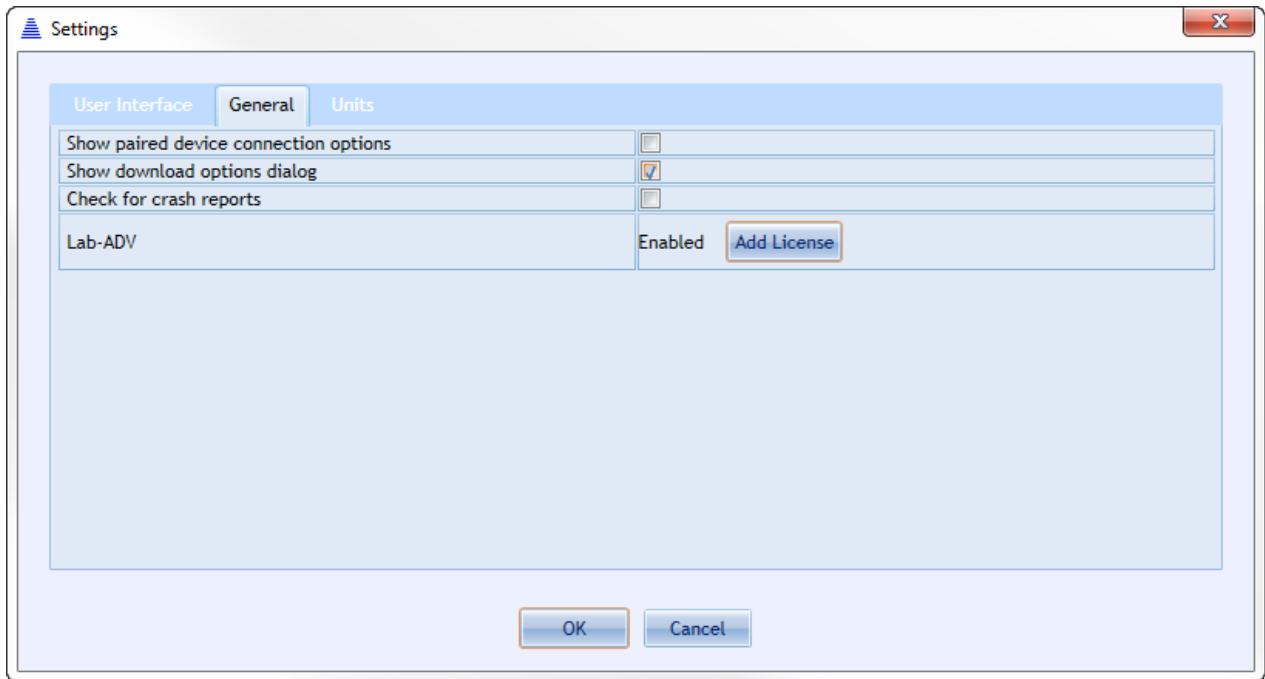

Figure 15:2 – Upload of License File for Lab-ADV

15.3. Lab-ADV Configuration

The Lab-ADV Configuration settings specified in Table 15:1 allows the user to define the data collection process within Communication, System, Environmental and Data Management categories. The configuration settings are application dependent and will vary depending on the specific measurement requirements.

Table 15-1. Configuration Settings

Category	Value	Description
Communication	COM Port	COM port assigned to FlowTracker2 probe assembly. It is recommended that the Windows Device Manager be used to determine assigned COM port.
	Sampling Rate	Sampling rate selected for measurement. The Lab-ADV has four sampling rates: 1, 2, 5, and 10 Hz.
Sampling	Velocity Range	Optimizes ADV operation for expected maximum velocity conditions. There are six velocity range settings: +/- 10, 20, 50, 100, 200 cm/s and Auto. Auto velocity range is the most robust setting under variable or unknown conditions. Auto is not available at the 10 Hz sample rate.

Category	Value	Description	
		Otherwise, generally it is best to select the lowest velocity range that will cover the maximum velocity expected in a given experiment. See Table 15-2 for descriptions of each velocity range.	
System	Run Automated BeamCheck on Start	Automated Beam Check will be performed before the measurement if this is selected.	
	Use Pressure Sensor	Collect Pressure Sensor data if the probe assembly is equipped with a Pressure Sensor.	
	Pressure Sensor Information	Air Pressure Cal. Period (min)	The Air Pressure Cal. Period (min) function sets the time limit between atmospheric pressure calibrations.
		Approximate Site Latitude (±deg)	Used for the calculation of Water Density based on Salinity (user entry), Latitude and Altitude.
Approximate Site Altitude (m)		Used for the calculation of Water Density based on Salinity (user entry), Latitude and Altitude.	
Environmental	Salinity (PSS-78)	User defined salinity value. This will be used in the sound speed calculation	
	Temperature Override (Optional)	User defined temperature value, to override the system's temperature sensor. This will be used in the sound speed calculation.	
	Sound Speed Override (Optional)	User defined sound speed value, to override internal sound speed calculations.	
	Mounting Correction	Mounting correction field can be used to correct for either flow disturbance or negative flows.	
Data Management	Logging Location	The logging location defines the folder where the measurement files will be stored	

Category	Value	Description
	Logging Duration Per File (min)	Defines a file logging limit based on a time duration.
	Logging Interval Start / End Time Alignment	<p>The Logging Interval Start / End Time Alignment works in combination with “Logging Duration Per File (min)”.</p> <p>If your logging duration per file is specified as 10 min and you start your logging at 17:03:25:</p> <ul style="list-style-type: none"> - Without logging interval alignment the next file will be started at 17:13:25, the third one at 17:23:25 and so on - With logging interval alignment the next file will be started at 17:20:00, the third one at 17:30:00 and so on

Table 15-2: Velocity Range Settings

Velocity Range	Absolute max velocity in arbitrary direction in ideal conditions	Absolute max velocity in X direction in ideal conditions	Recommended max velocity in arbitrary direction in ideal conditions	Recommended max velocity in X direction in ideal conditions
Auto	± 112 cm/s	± 448 cm/s	± 60 cm/s	± 200 cm/s
± 10 cm/s	± 10 cm/s	± 40 cm/s	± 3 cm/s	± 10 cm/s
± 20 cm/s	± 14 cm/s	± 52 cm/s	± 7 cm/s	± 20 cm/s
± 50 cm/s	± 27 cm/s	± 108 cm/s	± 15 cm/s	± 50 cm/s
± 100 cm/s	± 55 cm/s	± 220 cm/s	± 30 cm/s	± 100 cm/s
± 200 cm/s	± 112 cm/s	± 448 cm/s	± 60 cm/s	± 200 cm/s
<p>Ideal conditions consist of:</p> <ul style="list-style-type: none"> - ideal signal conditions (high SNR, low noise) - Ideal boundary conditions (no boundaries nearby) - Ideal temperature and sound speed (18°C and 1475 m/s) - For X direction velocity – uniform flow in X direction 				
<p>2D/3D FT2 probe would use the same recommendation with Z velocity maximum same as the arbitrary direction.</p>				

The Lab-ADV Configuration window, shown in [Figure 15:3](#), consists of two sections. The first requires the user to define the parameters specified in [Table 15:1](#). The second section consists of number of functions that enhance the measurement process.

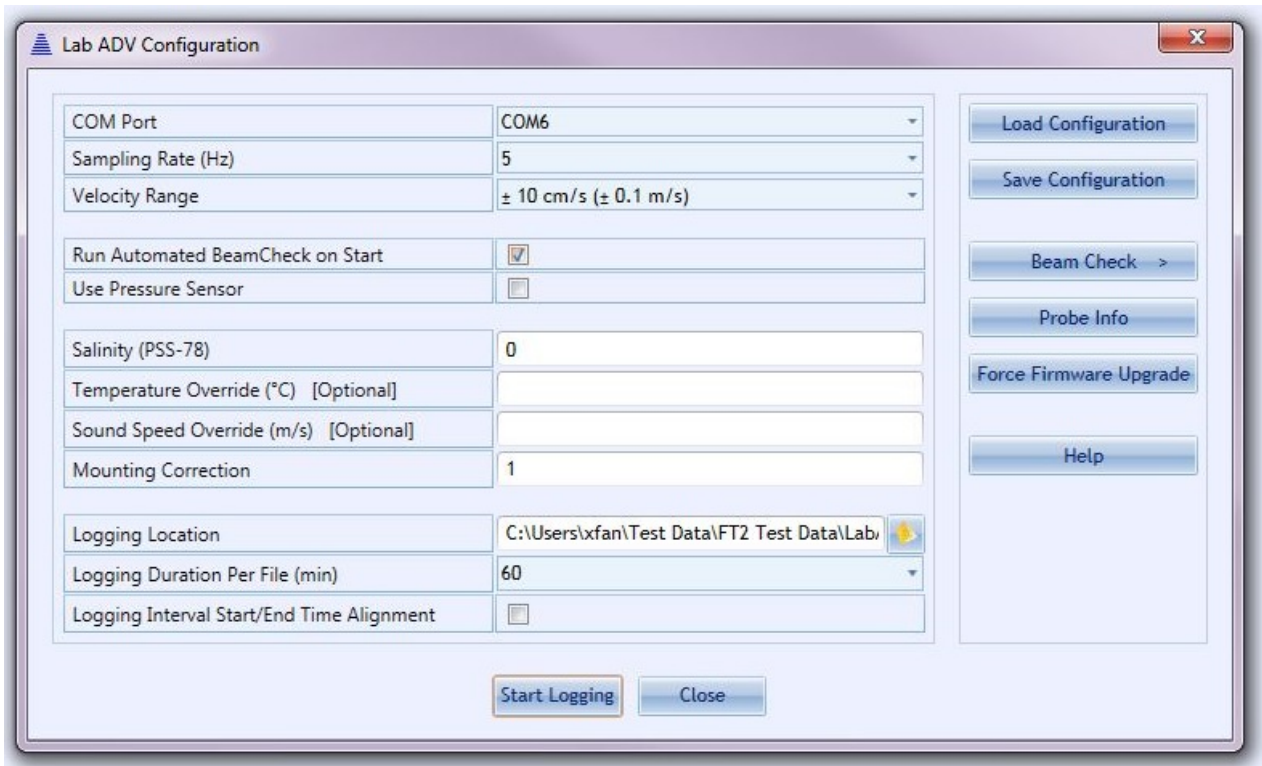

Figure 15:3 - Lab-ADV Configuration

15.3.1 Load Configuration

Load Configuration allows the user to upload a configuration file based on previous measurements configuration settings. This can simplify the setup process if the same settings will be used for multiple measurements.

15.3.2 Save Configuration

Save Configuration allows the user to create a configuration file based on the current configuration settings. The configuration file created will have the following file extension.

*.labadv_config

15.3.3 Beam Check

The Beam Check function enables the user to perform either a Manual Beam Check or Automated Beam Check.

Manual Beam Check

- a) Sampling Volume is defined by the **Grey** vertical line,
- b) Averaging of beam profile data,
- c) Beam Check file can be recorded during manual Beam Check

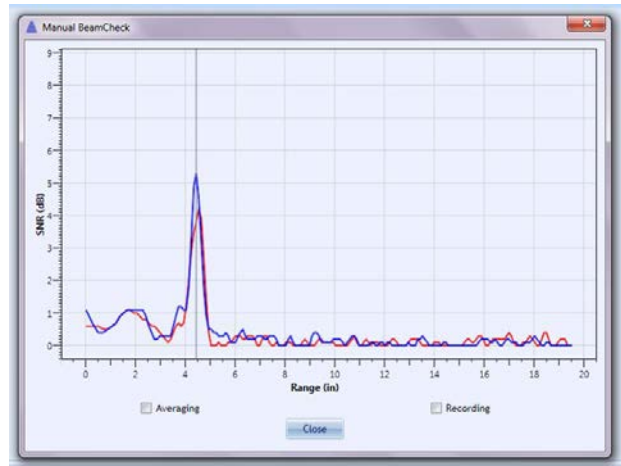

Figure 15:4 – Manual Beam Check

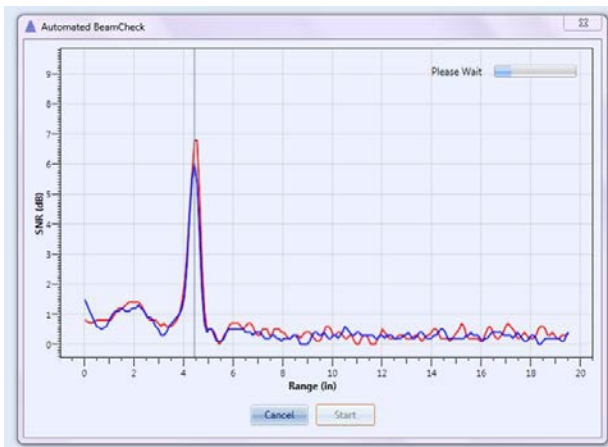

Figure 15:5 – Automated Beam Check

Automated Beam Check

- a) Deployment instructions are supplied before Automated Beam Check commences,
- b) The Lab-ADV collects approximately 12 seconds of beam profile data during the Automated Beam Check,
- c) Warnings will be supplied if any criteria was exceeded during the Automated Beam Check

15.3.4 Probe Info

Probe Info supplies the FlowTracker2 probe assembly information as recorded within the firmware, as shown in [Figure 15:6](#).

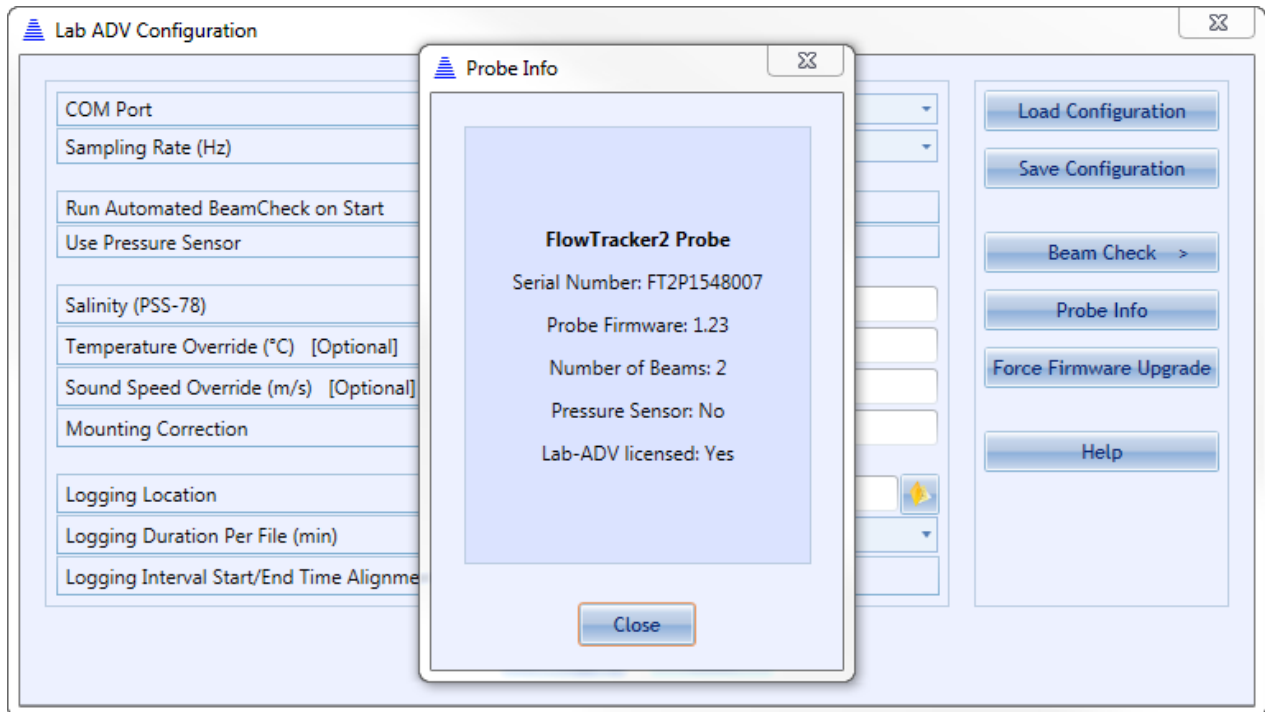

Figure 15:6 – Probe Info

15.3.5 Force Firmware Upgrade

The Force Firmware Upgrade option allows the user to either recover a probe without firmware or downgrade the firmware. The warning supplied during the operation is shown in [Figure 15:7](#).

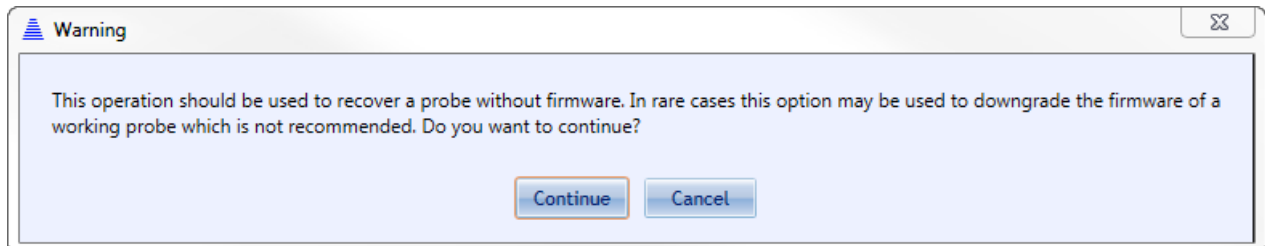

Figure 15:7 – Force Firmware Upgrade Warning

15.4. Data Collection

The Data Collection window displays the raw data collected by the FlowTracker2 ADV during the measurement, shown in [Figure 15:8](#). The variables and layouts displayed within the Data Collection window are defined under Display Settings. The Data Collection window displays the raw data of each variable in graphic form, along with a numerical display of the instantaneous samples. The data labels of each variable are defined by the instantaneous samples color code (red, blue or green).



Figure 15:8 – Data Collection Window

15.4.1 Display Settings

Display settings window, shown in [Figure 15:9](#) allows the user to define which variables should be displayed during data collection and the number of columns used for the layout.

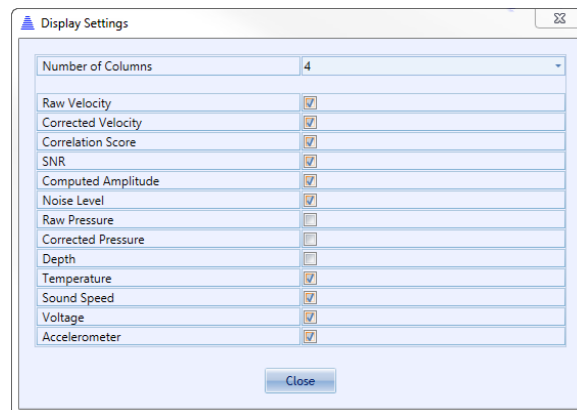

Figure 15:9 – Display Settings

15.4.2 Information

The information box supplied during data collection, shown in [Figure 15:10](#) gives the user key information regarding sampling rate, duration and number of samples collected.

Information

- a) Sampling Rate
- b) Start Time
- c) Last Sample Time
- d) Samples Recorded

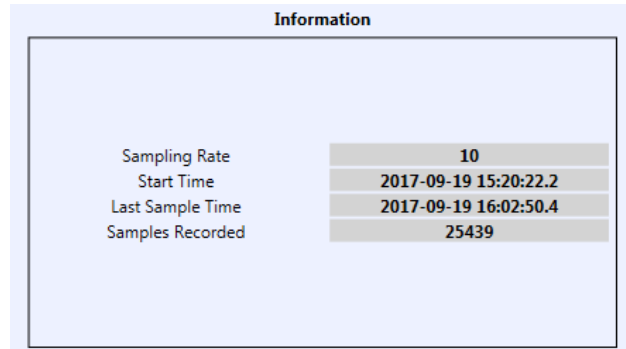

Figure 15:10 – Information Box

15.5. Data Export

The data collected during the measurement is automatically exported in a CSV format file after the measurement is completed. The file location is defined by the user under Logging Location in [Configuration Settings](#).

The variables exported in the CSV file is dependent on the FlowTracker2 ADV model used in the measurement. The following FlowTracker2 probe assembly models will determine the variables that are populated in the CSV file.

- 2D
- 2D / 3D
- 2D with Pressure Sensor
- 2D / 3D with Pressure Sensor



The variables displayed during data collection will not affect the data export. The exported file will include all available variables as determined by the probe assembly configuration, irrespective of the variables the user has chosen to display.

Properties associated with the variables and numerical calculations performed on the raw data collected are defined in [Table 15:3](#),

Table 15:3. CSV Data Export

Variable	Description	Units	Decimal
Operation			
UTC Time	Measurement time based on Coordinated Universal Time (UTC)	hh:mm:ss	
Local Time	Measurement time based on Local Time	hh:mm:ss	
Raw Velocity.X	Raw velocity, X velocity component	m/s or ft/s	4
Raw Velocity.Y	Raw velocity, Y velocity component	m/s or ft/s	4
Raw Velocity.Z	Raw velocity, Z velocity component	m/s or ft/s	4
Corrected	Corrected velocity, X velocity component.	m/s or ft/s	4



Variable	Description	Units	Decimal
Velocity.X	Mounting correction applied to velocity.		
Corrected Velocity.Y	Corrected velocity, Y velocity component. Mounting correction applied to velocity.	m/s or ft/s	4
Corrected Velocity.Z	Corrected velocity, Z velocity component. Mounting correction applied to velocity.	m/s or ft/s	4
Correlation Score.Beam1	ADV Correlation Score, range from 1 - 100	%	0
Correlation Score.Beam2	ADV Correlation Score, range from 1 - 100	%	0
Correlation Score.Beam3	ADV Correlation Score, range from 1 - 100	%	0
SNR.Beam1	Signal to noise ratio of Beam 1	dB	0
SNR.Beam2	Signal to noise ratio of Beam 2	dB	0
SNR.Beam3	Signal to noise ratio of Beam 3	dB	0
Computed Amplitude.Beam1	Amplitude of Beam 1. Computed from SNR and Noise of Beam 1	cnts	0
Computed Amplitude.Beam2	Amplitude of Beam 2. Computed from SNR and Noise of Beam 2	cnts	0
Computed Amplitude.Beam3	Amplitude of Beam 3. Computed from SNR and Noise of Beam 3	cnts	0
Noise Level.Beam1	Noise level of Beam 1	cnts	0
Noise Level.Beam2	Noise level of Beam 2	cnts	0
Noise Level.Beam3	Noise level of Beam 3	cnts	0
Temperature	Internal temperature measurement	°C or °F	2
Sound Speed	Sound Speed to compute velocity from the measured Doppler Shift. Sound Speed is either internally calculated or user entry	m/s or ft/s	3
Raw Pressure	Raw pressure	dBar	
Corrected Pressure	Corrected pressure for Bernoulli effect	dBar	
Depth	Water depth calculated based on corrected pressure	m or ft	
PS Calibration	User defined period between calibration of pressure sensor against atmospheric pressure	min	
Voltage	Voltage of power supply	V	3



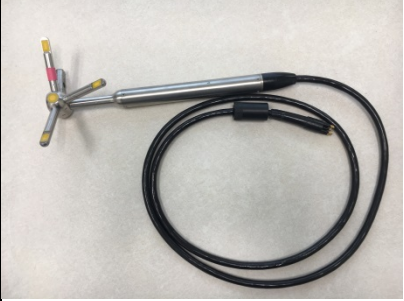

Variable	Description	Units	Decimal
Accelerometer.X	Raw X acceleration		5
Accelerometer.Y	Raw Y acceleration		5
Accelerometer.Z	Raw Z acceleration		5

15.6. Power and Communication Cable

The Power and Communication Cable connects the FlowTracker2 probe assembly to the power supply and Windows PC or Tablet. The hardware components associated with the FlowTracker2 Lab-Adv application are listed in [Table 15:3](#).

Table 15-3. FlowTracker2 Lab-Adv Hardware Components

Component	Description
2D side-looking 10 MHz ADV probe assembly	FlowTracker2 2D side-looking 10 MHz ADV probe assembly 
2D/3D side-looking 10 MHz ADV probe assembly	FlowTracker2 2D/3D side-looking 10 MHz ADV probe assembly 
FlowTracker2 probe assembly sensor extension cable	The FlowTracker2 probe assembly extension cables are available in three different lengths. <ul style="list-style-type: none"> • 1.5m, • 3.5m, • 8.5m. 
	 It is recommended that the maximum extension cable length of 8.5m not be exceeded, for a total cable length of 10m.

Component	Description	
Power and Communication Cable	Power and Communication Cable (1m, RS232) 	
Power Supply	AC/DC Power Supply: 12VDC, 20W, 1.67A 	
RS232 Cable	RS232 Cable 	
		Data transmission between FlowTracker2 probe assembly and PC / Tablet can be impacted if the RS232 cable length exceeds the maximum recommend length. Performance of FlowTracker2 Lab-ADV application was verified using 8.5m extension cable and 33.3m RS232 cable.
RS232 to USB Converter	RS232 to USB Converter 	

Appendix A. Software Flow Diagram

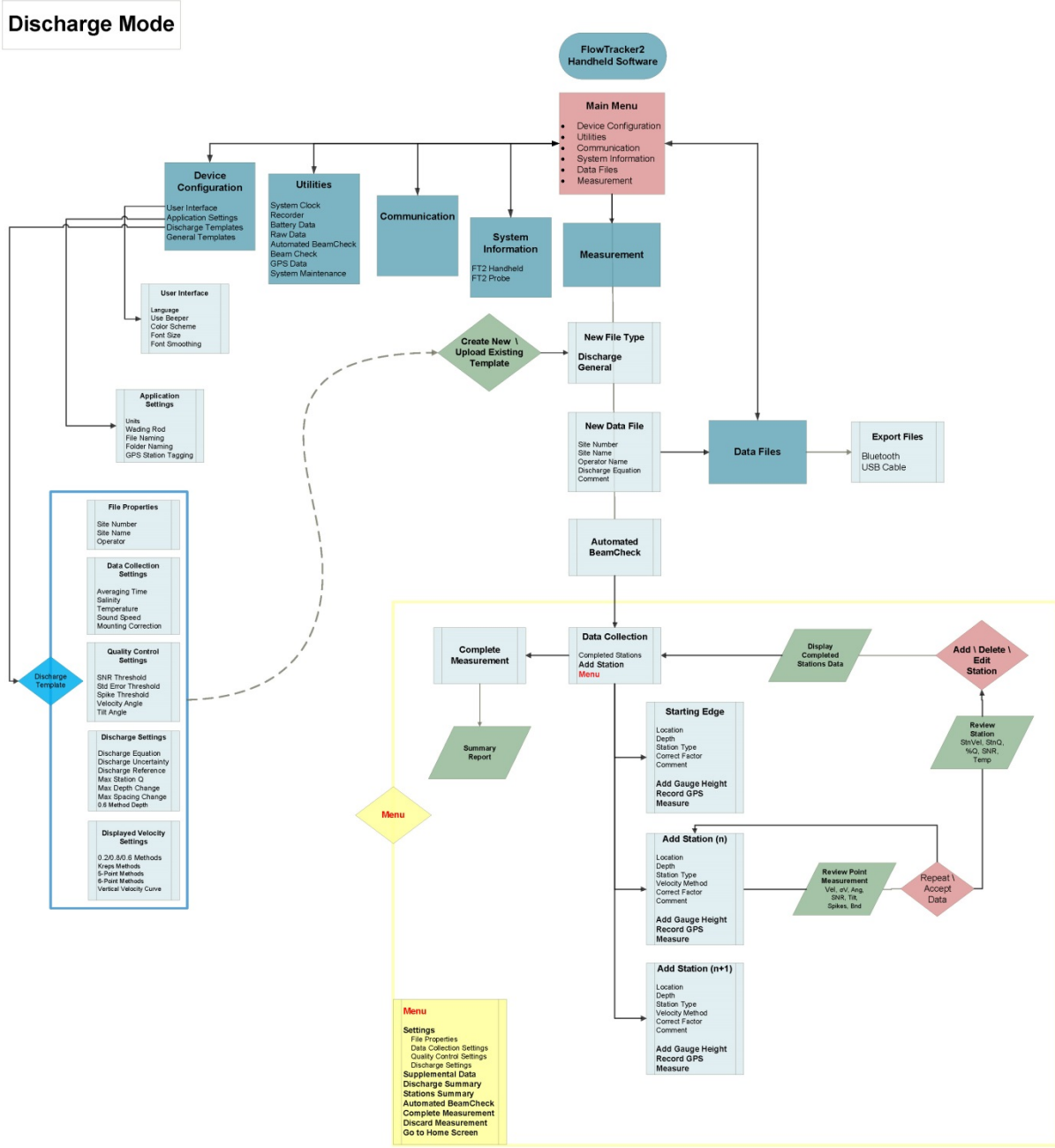

General Mode

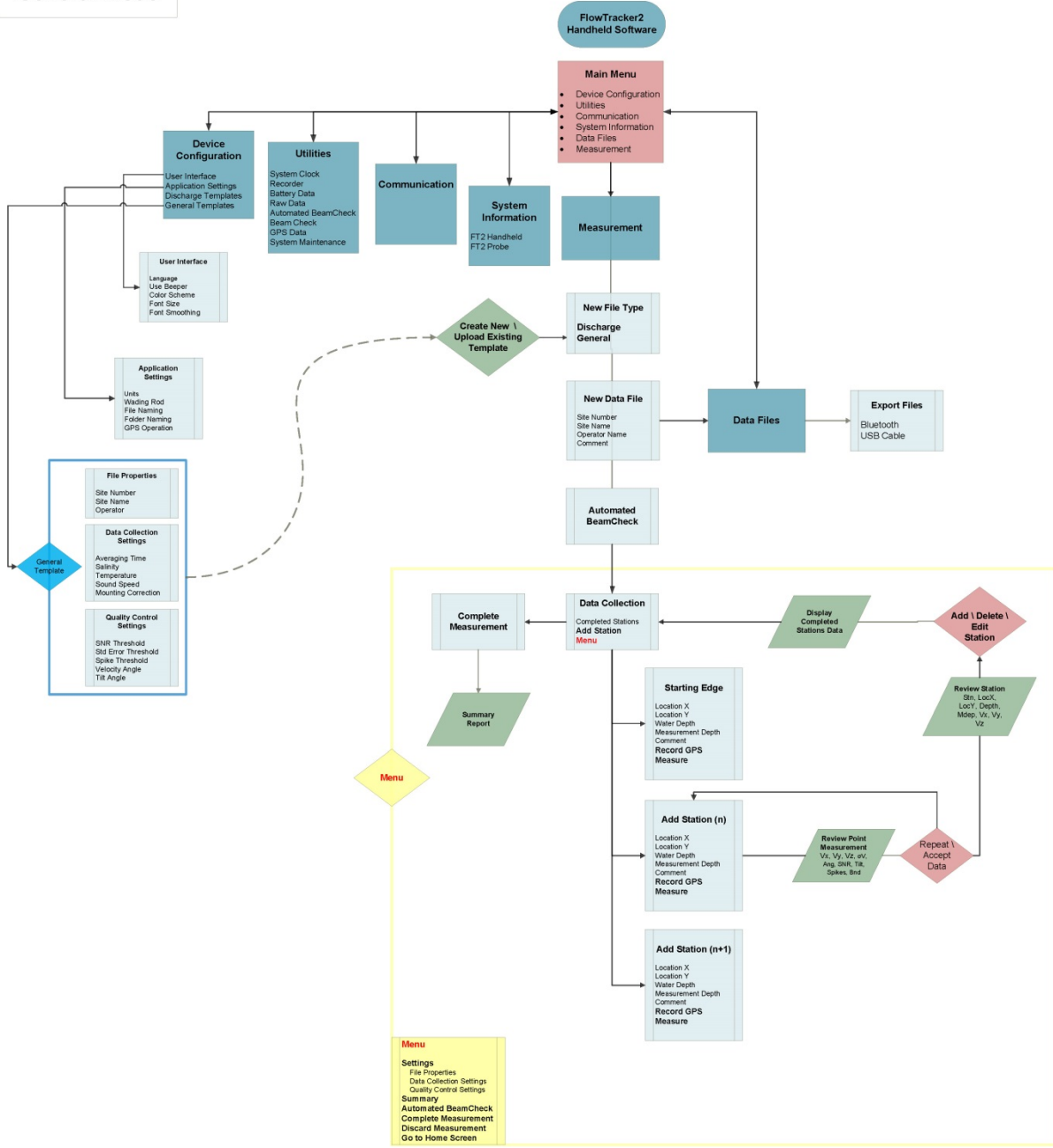

Appendix B. Site Selection Requirements

The **Site Selection Requirements** for performing discharge measurements using a FlowTracker2 instrument are based on a number of measurement site and hydraulic requirements. The measurement site and hydraulic requirements are similar to what a Hydrologists or Hydrographer will use in the selection of monitoring site for either natural or artificial control. The site and hydraulic requirements that need to be taken into account with every discharge measurement are summarized under the following points.

- a) Uniform flow conditions throughout the measurement section,
- b) Straight length of channel with uniform cross-section and slope (10 times section width).
- c) Flow in the channel should be confined to a single well-defined channel with stable banks.
- d) Avoid a site with wide shallow sections or secondary side channels.
- e) Bends upstream of site should be avoided as this will result in angular flow towards tagline,
- f) Steep slopes upstream should be avoided as this could result in high approach velocities at the measurement site causing turbulent flow conditions.
- g) Avoid measurement sections with deep pools as the reduction in velocity normally diverge from uniform flow conditions,
- h) Avoid prominent obstructions in a pool or excessive plant growth that can affect the flow pattern.
- i) Turbulent flow conditions should be avoided if possible.
- j) Negative and or back flow should be avoided at all times.
- k) Flow conditions must be within the instrument and equipment specifications

Appendix C. Japanese Method Example

The measurement example of the Japanese method given in Appendix C is based on an actual field measurement that was manually calculated to give an overview of the various steps involved. The section of the measurement site was greater than 10m and based on the [Japanese Method](#), the measuring technique applicable is [Equation 5:3](#).

Equation 5:1 - Japanese Method > 10m

$$Q = \sum \left\{ \left[(b_1 - b_0) \times 0.5 \left(\frac{d_1+d'_1}{2} + \frac{d_0+d'_0}{2} \right) + (b_2 - b_1) \times 0.5 \left(\frac{d_2+d'_2}{2} + \frac{d_1+d'_1}{2} \right) \right] \times \left(\frac{\bar{v}_1 + \bar{v}'_1}{2} \right) \right\} +$$

Edge

$$\left\{ \left[(b_n - b_{n-1}) \times 0.5 \left(\frac{d_n+d'_n}{2} + \frac{d_{n-1}+d'_{n-1}}{2} \right) + (b_{n+1} - b_n) \times 0.5 \left(\frac{d_{n+1}+d'_{n+1}}{2} + \frac{d_n+d'_n}{2} \right) \right] \times \left(\frac{\bar{v}_n + \bar{v}'_n}{2} \right) \right\}$$

Open Water

Items to be field in the field survey										Items to be filled after survey						
Stn no	Dist from Bank (m)	Depth (m)			Velocity					Velocity		Station Area			Disc. (m ³ /s)	
		When going	When back	Average	Meas depth	Sound no.	Meas. Time (s)			Vel. (m/s)	Ave. (m/s)	Ave. Depth	Ave Width	Area (m ²)		Sum (m ²)
							1 st	2 nd	Ave							
0	0	0.00	0.00	0.00												
1	2	1.15	1.16	1.16	0.23	9	25.0	25.6	25.3	1.20	1.16	0.58	2.00	1.16	3.32	3.85
					0.92	9	26.6	28.2	27.4	1.11		1.08	2.00	2.16		
2	4	1.00	1.00	1.00								0.90	2.00	1.80		
3	6	0.80	0.80	0.80	0.16	9	21.8	22.0	21.9	1.38	1.20	0.73	2.00	1.46	3.26	3.91
					0.64	9	30.8	29.4	30.1	1.01						
4	8	0.66	0.65	0.66								0.60	2.00	1.20		
5	10	0.54	0.54	0.54	0.32	6	23.1	23.0	23.0	0.88	0.88	0.50	2.00	0.92	2.20	1.94
					--	--	--	--	--	--						
6	12	0.45	0.45	0.45								0.46	2.00	0.92		

Appendix D. Measurement Equipment List

Cat.	Items	Quantity	Description
FlowTracker2	Probe	1	FlowTracker2 probe with cable
	Handheld	1	FlowTracker2 handheld
	Battery Cartridge	2	Battery cartridge for FlowTracker2
	Handheld Bracket	1	Handheld bracket to mount handheld to Top Setting Rod
	Top Setting Rod	1	Top setting wading rod
	S Bracket Screw	1	Screw to clamp probe to S bracket
	USB Cable	1	USB cable to download data from FlowTracker2
Safety Gear	Mobile \ Satellite Phone	1	Contact office, local authorities or emergency services
	Drink Water	1pp	5L drink water per person per day
	Night-day Safety Vest	1pp	Required when working during low visibility or from bridges \ culverts
	Road Signs	2	Required when working from bridges \ culverts
	Sun Hat	1pp	Large brim hat
	Rain Jacket	1pp	Only to be used when raining
	Wader or Water Boots	1pp	Select type of water proof boots based on the water depth.
	Life Jacket	1pp	When entering water an approved life jacket must be worn.
	First Aid Kit	1	Require first aid certificate
	Sunscreen	1	
	Insect repellent	1	Midge and Mosquito
Measurement Gear	Measuring Tape	1	Measuring tape length dependent on section width.
	Pocket Tape	1	Verify water depth or instrument setting.
	Steel Pegs	2	To anchor the measuring tape on both banks
	Hammer	1	5lb
	Shovel \ Rake	1	Shovel \ Rake to clean measurement section
	Camera	1	Photographs of measurement site and flow conditions
Reference	Laptop \ Tablet	1	Download measurements at measurement site to evaluate on desktop software
		1	CastAway , Verify water temperature and salinity (see Principle of Operations).

pp – per person

Appendix E. CE Declaration of Conformity



DECLARATION OF CONFORMITY

Manufacturer’s Name: SonTek, a Xylem brand
Manufacturer’s Address: 9940 Summers Ridge Road
 San Diego, CA 92121 U.S.A.

SonTek, a Xylem brand, DECLARES THAT THE FOLLOWING PRODUCTS:

Equipment Type: Flow Meter
Model: FlowTracker 2
Product Names: FlowTracker 2, FlowTracker 2 Lab-ADV

CONFORMS TO THE FOLLOWING EUROPEAN UNION COUNCIL DIRECTIVES:

EMC DIRECTIVE 2004/108/EC

TEST SPECIFICATIONS	BASIC STANDARDS
EN 61326-1: 2013	EN 55011
IEC 61326-1:2012	EN 55022
FCC 47 CFR PART 15, SUBPART B	EN 55032
FCC 47 CFR PART 18	EN 61000-3-2
ICES-003 ISSUE 4	EN 61000-3-3
	EN 61000-4-2
	EN 61000-4-3
	EN 61000-4-4
	EN 61000-4-5
	EN 61000-4-6
	EN 61000-4-8
	EN 61000-4-11
	ANSI C63.4

RoHS 2 DIRECTIVE 2011/65/EU

Per the current RoHS Directive, the FlowTracker 2 and FlowTracker 2 Lab are classified as Category 9 Industrial Control and Monitoring Instruments and comply with the RoHS 2 Directive. However, due to the presence of piezo electric transducers in our product, with respect to exemptions permitted in Annex IV, section 14 & 15 of the RoHS Directive, the application of lead in single crystal piezo electric materials for ultrasonic transducers is exempted from the restriction in Article 4. All other components comply with the RoHS Directive.

WEEE DIRECTIVE 2012/19/EU

BATTERY DIRECTIVE 2006/66/EC

RADIO EQUIPMENT DIRECTIVE (RED) 2014/53/EU

SAFETY CERTIFICATION
IEC 61010-1:2010

CONFORMS TO THE FOLLOWING KOREAN TEST SPECIFICATIONS:

TEST SPECIFICATIONS
KN 61326-1
KN 11



E.J. Rollo
Compliance Engineer
SonTek – a Xylem brand

INDEX

A

Accessing Templates · 38
 accuracy · 223
 Add Station · 118, 155
 ADV Firmware · 178
Air Pressure Cal. Period (min)
 · 37
 Alkaline · 56
 Application Settings · 31
 Automated Beam Check · 61,
 100, 114, 144, 151, 169
Automatic · 35
Averaging Time · 19, 42

B

Bank (left or right) · 121
Base Template · 39
 Battery Cap · 184
Battery Compartment · 17
 Battery Data · 56
 Battery Indicator · 60
 Battery Type · 56
 Battery Voltage · 57
 Beam Check · 62, 95
 Beam Check Features · 96
 Beam Check Operation · 97
 Beam Check Overview · 95
 Beam Geometry · 221
 Beeper · 30
 bistatic · 221
 bottom · 32
Bottom banner · 23
 boundary adjustment · 221

C

Cable Maintenance · 183
 Cartesian (xyz) · 221
CastAway-CTD · 43
Channel Banks · 73
 Color Scheme · 30
Comma Separated Values ·
 201
 Communication · 26
Communication Connector ·
 17

Complete Measurement · 145,
 170
 Condensation · 184
 conductivity · 43
 Configuration Templates · 38
Confirmation · 119, 120, 156
 considerations · 224
 Correction Factor · 75
 Create Measurement · 112, 149

D

Data Collection · 117, 154
 Data Collection Menu · 140, 167
 Data Collection Modes · 66
 Data Collection Settings · 41
 Data Collection Window · 117,
 154
 Data Files · 27
 Data Management · 110
 Delete Station · 118, 119, 155,
 156
Deleting · 118, 155
Depth · 76
 Depth Only · 74
 Desktop Software · 178
 Determining Mean Station
 Velocity · 72
 Determining Mean Velocity · 79
 Device Configuration · 24, 29
 Diagnosing Measurements with
 Beam Check · 97
Disabled · 36
 Discard Measurement · 146, 171
 Discharge · 40
 Discharge Calculation Methods ·
 67, 121, 122, 126, 132
 Discharge Equation · 48
 Discharge Measurement · 112
 Discharge Mode · 66
 Discharge Reference · 49
 Discharge Settings · 47
 Discharge Summary · 142
 Discharge Uncertainty · 48
 Discharge Uncertainty
 Calculation · 75
Discharge Velocity Methods ·
 51
 Displayed Velocity Methods · 50

E

Edges · 68, 70, 72
 Edit Station · 119
Editing · 119
 English · 32
 Equipment List · 103
 Erase Recorder · 55
 Evaluate Beam Check Results ·
 115, 152

F

Field Applications · 185
 File Format · 190
 File Framework · 191
 File Naming · 33
 File Properties · 40
 File Structure · 192
 Flow Interference · 226
 Folder Naming · 34
Follow Number · 34
 Font Size · 31
Fractional Depth Measurement
 · 129, 136

G

General · 40
 General Measurement · 149
 Go to Home Screen · 147, 171
 GPS Data · 63
 GPS Station Tagging · 34
 Graph Range · 97
 Graph SNR · 97

H

Handheld · 17, 19
 Handheld Mounting Bracket ·
 180
 Handheld Software · 178
 Hardware Inspection · 104
 Health and Safety · 188
 Housing · 184

I

Ice · 124
 Interpolated Variance Estimator · 48
Interpolated Variance Estimator (IVE) · 75
 Island Edge · 122
 Islands · 68, 70, 72
ISO · 75
 ISO 748 - 2007 · 48

J

Japanese Method · 48
 JSON File · 190

K

Keypad · 17, 21
Keypad Filter · 23

L

Language · 29
LCD Screen · 17
 Left Bank · 122
 Left Soft Key · 23

M

Main · 24
 Manage Recorder · 54
Manual · 35
 Manual Change · 52
 Max Depth Change for Warning · 49
 Max Spacing Change for Warning · 50
 Max Station Q for Warning · 49
 Mean-Section Equation · 69
 Mean-Section Method · 48
 Measured Discharge · 49
 Measurement · 26, 112, 149
Measurement Location · 19
 Measurement Procedure · 107
 Measurement Process · 103
Measurement Site Information · 106
 Measurement Summary · 147, 171

Measurement Technique · 66, 78
 Method None · 73
 Metric · 32
 Mid-Section Equation · 67
 Mid-Section Method · 48
 Mounting Correction · 44
 mounting, probe · 224

N

New Data File · 113, 150
 New File Type · 112, 149
 New Template · 39
 NiMH · 56
 Noise Level · 96

O

Office Diagnostic · 104
 Office Procedures · 103
 On/Off Switch · 21
Open Station · 119
 Open Water · 123
 O-rings · 184

P

Peak Level · 97
 Peak Position · 97
 Percentage Full · 57
Ping · 19
Ping Rate · 19
 Point Velocity Measurement · 126, 133, 156, 161
 Post Measurement Requirements · 109
Practical Salinity Scale · 42
 Pre Measurement Diagnostics · 106
Predefined Languages · 29
Pressure · 61
 Pressure Sensor · 64
Probe · 17
Probe cable · 17
 probe configurations · 224
 Probe Mounting Bracket · 181
Probe Offset From WR Bottom · 37
 Probe orientation · 226
Properties · 37, 41, 42, 45, 47, 51, 53, 54, 63, 122, 123, 124, 125, 130, 131, 137, 139, 142,

143, 147, 155, 159, 160, 165, 166, 168, 172, 282
 pulse-coherent · 220

Q

quality control · 224
 Quality Control · 80
Quality Control Data · 19
 Quality Control Parameters · 80
 Quality Control Settings · 44
Quality Control Warning Message · 92

R

Rated Discharge · 49
 Raw Data Display · 57
 receivers · 218
Receivers · 18
 Record GPS Location · 35
 Recorder · 54
 reference · 43, 44
 Review Measurement Summary · 110
 Review of Measurement Site Information · 109
 Review Point Measurement · 129, 137, 158, 164
Review Station · 120
 Review Station Measurement · 130, 138, 159, 166
 Right Soft Key · 23
 Routine Maintenance · 182

S

Salinity · 19, 42
Sample · 19, 96
 Sample Averaged · 96
 sampling strategy · 223
 sampling volume · 218
Sampling volume · 18
 Sampling Volume · 221
 Scattering Material · 185
 Screen Layout · 23
 Seeding · 185
 Selecting Template · 39
Setting Fractional Depth · 128, 135, 157, 163
Setting Measurement Depth · 157, 163
 Settings · 140, 167

Signal Strength · 19
 Signal to Noise Ratio · 81, 219
Signal-to-Noise Ratio (SNR) · 19
 SNR · 81
 SNR Raw Data · 59
 SNR Threshold · 45
 soft key · 21
 Software Upgrade · 178
Sound Speed · 19, 43
Sound Velocimeters · 42, 44
 Spike Threshold · 46
 Stage - Discharge Relationship · 110
 Standard Error · 46
 Start Automated Beam Check · 115, 152
Station Measurement · 125, 132, 156, 161
 Station Parameters · 126, 133
 Station Summary · 143
 Station Type · 120
 Station Types · 121
 Std Error Threshold · 46
 Storage · 111
 Structures · 226
 Supplemental Data · 141
 Sync with GPS Time · 53
 System Clock · 52
 System Information · 26
 System Maintenance · 65
 System Operation · 21

T

Temperature · 20, 43
 Temperature Raw Data · 60
Temperature sensor · 18
 Template Functions · 40
Template Main Screen · 39
Template Name · 39
Templates · 38
 The Doppler Shift · 217
 Tilt Angle Warning · 46
 Tilt Raw Data · 60
 Timing of Warning Messages · 94
Top banner · 23
 Transducers · 183
 transmitter · 218
Transmitter · 18

U

Units · 31
Units System · 31
 Upgrading ADV Firmware · 180
 Upgrading Handheld Software · 178
Use Pressure Sensor · 36
 User Interface · 29
UTC · 20
 Utilities · 25, 52

V

Velocity · 76
 Velocity Angle for Warning · 46
 velocity data · 223
Velocity Measurement · 158, 164
Velocity Method · 119, 120, 126, 133
 Velocity Raw Data · 58
 Velocity Standard Error · 84
 Velocity Summary · 168
 Vertical Velocity Curve · 74

W

Wading Rod · 32
 water surface · 32
Width · 76

Z

Zinc Anodes · 184