

For Sales & Service Contact

geotech

2650 E. 40th Ave. • Denver, CO 80205
Phone 303-320-4764 • Fax 303-322-7242

1-800-833-7958

www.geotechenv.com

CX-04

Operator's Manual

Part Number: 71-0559

Revision: 0

Released: 1/11/23

RKI Instruments, Inc.
www.rkiinstruments.com

WARNING

Read and understand this instruction manual before operating instrument. Improper use of the gas monitor could result in bodily harm or death.

Maintenance of the gas monitor is essential for proper operation and correct readings.

Bump test the instrument before each day's use with a known concentration of the target gas. A bump test can be done in User Mode's BUMP item or by applying gas in Measuring Mode. The instrument does not need to be calibrated unless it does not pass the User Mode bump test or does not respond appropriately, as defined by the user, in Measuring Mode. For more information about bump test and calibration requirements, see IEC 60079-29-2.

Table of Contents

Chapter 1: Introduction	7
Overview	7
About the CX-04	7
Specifications	8
About this Manual	10
Chapter 2: Description	11
Overview	11
Instrument Description	11
<i>Case</i>	11
<i>LCD</i>	11
<i>Control Buttons</i>	12
<i>Alarm LED</i>	12
<i>Buzzer</i>	12
<i>Vibrator</i>	12
<i>Sensor</i>	13
<i>Filters</i>	13
<i>Infrared Communications Port</i>	13
<i>Batteries</i>	13
Standard Accessories	14
<i>Alligator Clip</i>	14
Optional Accessories	15
<i>Watch Band</i>	15
<i>Calibration Cup</i>	16
<i>IrDA/USB Cable</i>	16
Chapter 3: Measuring Mode	17
Overview	17
Start Up	17
<i>Turning On the CX-04</i>	17
<i>Performing a Demand Zero</i>	22
<i>Turning Off the CX-04</i>	22

Measuring Mode Operation	23
<i>Monitoring an Area</i>	23
Alarms	24
<i>Alarm Indications</i>	24
<i>Responding to Alarms</i>	26
Data Logging	29
Chapter 4: Display Mode	30
Tips for Using Display Mode	31
Gas Name Screen	31
Peak Screen (PEAK).....	31
STEL Screen (STEL)	32
TWA Screen (TWA)	32
User ID Screen (USER ID).....	32
Station ID Screen (STN ID)	33
Last Successful Calibration Date (CAL.DATA).....	34
Last Successful Bump Test Screen (BP.DATA)	35
Date/Time Screen (DATE)	35
Temperature Screen (TEMP)	35
Alarm Points Screen (ALARM--P)	36
Adjusting the Buzzer Volume (BUZZ.VOL)	37
Chapter 5: User Mode and Calibration	38
Overview.....	38
Entering User Mode	42
Tips for Using User Mode	43
Performing a Bump Test (BUMP)	43
Performing a Calibration (GAS CAL)	49
Setting Calibration Parameters (CAL SET)	63
Setting Bump Test Parameters (BUMP.SET)	65
Alarm Settings (ALARM--P).....	69
Updating the Lunch Break Setting (LUNCH)	71
Setting the Confirmation Beep and Non-Compliance Indicator (BEEP).....	72
Updating the Backlight Time (BL TIME).....	73

Turning the Key Tone On/Off (KEY.TONE)	74
Display Mode Items (DISP.SET)	74
Zero Suppression (ZERO.SUP)	75
Zero Follower (ZERO.FLW)	75
Turning Easy Calibration On/Off (E-CAL)	75
Setting the Date/Time (DATE)	76
Turning the Password On/Off (PASS-W)	76
Viewing the ROM/SUM (ROM/SUM)	77
Entering Measuring Mode (START)	77
Chapter 6: Maintenance	79
Overview	79
Troubleshooting	79
Replacing the Batteries	80
Replacing the Charcoal Filter	82
Replacing the Hydrophobic Filter	85
Replacing the Sensor	87
Chapter 7: General Parts List	89
Appendix A: Maintenance Mode	91
Overview	91
Entering Maintenance Mode	93
Tips for Using Maintenance Mode	94
Performing a Calibration (GAS CAL)	94
Performing a Gas Test (GAS.TEST)	94
Sensor/Battery Replacement Date (SEN.DATE)	96
Performing a Bump Test (BUMP)	96
Setting Alarms to Latching or Self-Resetting (LATCH)	97
Turning the Demand Zero Function On/Off (D.ZERO)	97
Turning the Auto Zero Function On/Off (A.ZERO)	98
Turning the ID Display Function On/Off (ID DISP)	98
Turning the Zero Suppression On/Off (ZERO.SUP)	99
Turning the Zero Follower On/Off (ZERO.FLW)	99
User Mode Zero Suppression (ZSUP.DSP)	99

User Mode Zero Follower (ZFLW.DSP)	99
Cylinder Setting (CYL.DISP).....	99
Setting the Date/Time (DATE)	100
Turning the Password On/Off (PASS-W).....	100
Viewing the ROM/SUM (ROM/SUM).....	101
Performing a Default (M.DEF).....	102
Entering Measuring Mode (START)	102

Appendix B: Gas Select Mode..... 103

Overview.....	103
Entering Gas Select Mode	103
Tips for Using Gas Select Mode.....	104
Saving the Alarm Points (SAVE-AP).....	104
Turning the Calibration Max Span On/Off (MAX.SPAN).....	105
Stealth and Vibrator Settings (STEALTH).....	106
Exiting Gas Select Mode (START).....	106

Warranty..... 107

WARNING: *Understand manual before operating. This is an intrinsically safe product. Substitution of components may impair intrinsic safety. To prevent ignition of a hazardous atmosphere, batteries must only be changed or charged in an area known to be nonhazardous. Not tested in oxygen enriched atmospheres (above 21%).*

AVERTISSEMENT: *Comprendre le manuel avant de l'utiliser. Ceci est un produit intrinsèquement sûr. La substitution de composants peut nuire à la sécurité intrinsèque. Pour éviter l'inflammation d'une atmosphère dangereuse, les batteries ne doivent être remplacées ou chargées que dans une zone non dangereuse. Non testé dans des atmosphères enrichies en oxygène (plus de 21%).*

Chapter 1: Introduction

Overview

This chapter briefly describes the CX-04 gas monitor. This chapter also describes the *CX-04 Operator's Manual* (this document). Table 1 at the end of this chapter lists the specifications for the CX-04.

About the CX-04

Using an advanced detection system, the CX-04 personal gas monitor detects the presence of carbon monoxide (CO) and oxygen (O₂). The CX-04's compact size and easy-to-use design make it ideally suited for a wide range of applications, including sewage treatment plants, utility manholes, tunnels, hazardous waste sites, power stations, petrochemical refineries, mines, paper mills, drilling rigs, and fire fighting stations. The CX-04 offers a full range of features, including:

- Liquid crystal display (LCD) for complete and understandable information at a glance
- Ultrabright alarm LED
- Distinctive audible/vibrating alarms for dangerous gas conditions and audible alarms for unit malfunction
- Microprocessor control for reliability, ease of use, and advanced capabilities
- Data logging functions
- Alarm trend data
- STEL (CO only), TWA (CO only), and over range alarms
- Peak reading
- Built-in time function
- Lunch break feature
- QPS "C/US" classification for Class I, Division I, Groups A, B, C, and D hazardous atmospheres

WARNING: *The CX-04 detects oxygen deficiency and elevated levels of oxygen and carbon monoxide which can be dangerous or life threatening. When using the CX-04, you must follow the instructions and warnings in this manual to assure proper and safe operation of the unit and to minimize the risk of personal injury. Be sure to maintain and periodically calibrate the CX-04 as described in this manual.*

AVERTISSEMENT: *Le CX-04 détecte un manque d'oxygène et des niveaux élevés d'oxygène et de monoxyde de carbone qui peuvent être dangereux ou mettre la vie en danger. Lorsque vous utilisez le CX-04, vous devez suivre les instructions et les avertissements de ce manuel pour assurer un fonctionnement correct et en toute sécurité de l'appareil et pour réduire les risques de blessures. Assurez-vous de maintenir et d'étalonner périodiquement le CX-04 comme décrit dans ce manuel.*

Specifications

Table 1: Standard Sensor Specifications/Alarm Points

	Carbon Monoxide (CO)	Oxygen (O₂)
Detection Range	0 - 2,000 ppm	0 - 40.0% volume
Lowest Detectable Limit (LDL)	3 ppm	n/a
Reading Increment	0 - 300 ppm: 1 ppm 310 - 2,000 ppm: 10 ppm	0.1% volume
Warning Factory Setting	25 ppm	19.5% volume, decreasing
Alarm Factory Setting	50 ppm	18.0% volume, decreasing
Alarm H Factory Setting	1,200 ppm	23.5% volume, increasing
STEL Alarm	200 ppm	n/a
TWA Alarm	25 ppm	n/a

Table 2: CX-04 Specifications

Sampling Method	Diffusion
Response Time	T90 Within 10 Seconds
Display	Graphics LCD Display

Operating Temperature & Humidity	Continuous environment: -20°C to 50°C/10 to 90% RH Temporary environment (up to 15 minutes): -40°C to 60°C/0 to 95% RH
Safety/Regulatory	<ul style="list-style-type: none"> • ATEX: Certificate Number DEKRA 19ATEX0097 II 1G Ex ia IIC T4 Ga (with alkaline batteries) II 1G Ex ia IIC T3, Ga (with Ni-MH batteries) • IECEx: Certificate Number IECEx DEK 19.0059 Ex ia IIC T4 Ga (with alkaline batteries) Ex ia IIC T3 Ga (with Ni-MH batteries) • QPS classified, “C/US”, as Intrinsically Safe. Exia. Class I, Groups A, B, C, & D.
Instrument Power Information	<ul style="list-style-type: none"> • Operating Voltage: 3.0V • Operating Current: 1.0 mA • Operating Power: 3.0 mW
Power Supply	2 AAA alkaline batteries; 1.5V, 1.175 AH (Duracell MN2400 or PC2400) <u>OR</u> 2 AAA Ni-MH batteries; 1.2V, 800 mA (Panasonic Eneloop BK-4MCC)
Continuous Operating Hours @ 25 °C	Alkaline Batteries: 4,600 hours in Measuring Mode (Non Alarm Operation, Fully Charged) Ni-MH Batteries: 3,000 hours in Measuring Mode (Non Alarm Operation, Fully Charged)
Case	High-impact Plastic, RF Shielded, Dust and Weather Proof (IP67)
Standard Accessories	<ul style="list-style-type: none"> • Alligator clip • Rubber boot
Optional Accessories	<ul style="list-style-type: none"> • Belt clip • Calibration cup • Datalogging and Setup Programs (Windows® 7, 8, 10, and 11), available at www.rkiinstruments.com/04series • IrDA/USB Cable for connecting to a computer when using the Datalogging and Setup Programs (not needed if computer has an infrared port)
Dimensions and Weight	Approximately 67(H) x 54(W) x 24(D) mm (2.6”H x 2.1”W x 0.9”D) Approximately 93 g (3.3 oz.)

About this Manual

The *CX-04 Operator's Manual* uses the following conventions for notes, cautions, and warnings.

NOTE: Describes additional or critical information.

CAUTION: *Describes potential damage to equipment.*

WARNING: *Describes potential danger that can result in injury or death.*

Chapter 2: Description

Overview

This chapter describes the CX-04 instrument and its accessories.

Instrument Description

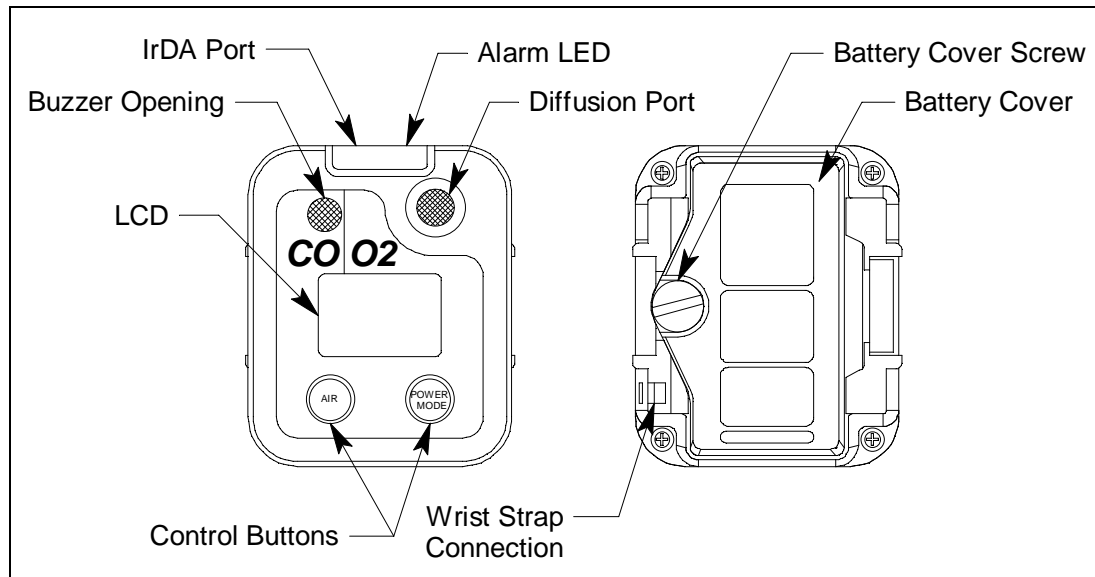

Figure 1: Component Location

Case

The CX-04's sturdy, high-impact plastic case is radio frequency (RF) resistant and is suitable for use in many environmental conditions, indoors and out. The case is dust proof and water resistant. A clear plastic window is located on the front of the case for viewing the LCD. The sensor retainer is located on the right side of the case and allows access to the filters and sensor. A feature in the lower left corner of the rear case is used to install the optional wrist strap.

LCD

A digital LCD (liquid crystal display) is visible through a clear plastic window in the top case. The LCD shows the gas reading. The LCD also shows information for each of the CX-04's operating modes.

Control Buttons

Two control buttons, AIR and POWER MODE, are located below the LCD.

Table 3: CX-04 Control Button Functions

Button	Function(s)
AIR	<ul style="list-style-type: none">• turns on LCD backlight• resets alarm condition if LATCH is set to ON in Maintenance Mode• enters User Mode, Maintenance Mode, and Gas Select Mode when used with POWER MODE• activates the demand zero function (adjusts the CX-04's fresh air reading)• changes the value of a parameter available for adjustment• scrolls through parameter options
POWER MODE	<ul style="list-style-type: none">• turns the CX-04 on and off• turns on LCD backlight• enters and scrolls through Display Mode• enters instructions into the CX-04's microprocessor• resets alarm condition if LATCH is set to ON in Maintenance Mode• enters User Mode, Maintenance Mode, and Gas Select Mode when used with AIR

Alarm LED

The alarm LED above the sensor and buzzer openings alerts you to gas, low battery, and failure alarms.

Buzzer

One solid-state electronic buzzer is located inside the case. Sound exits the case through a hole in the upper left corner of the front case. The buzzer sounds for gas alarms, malfunctions, and low battery voltage. It also provides feedback for button presses and while in Display, User, Maintenance, or Gas Select Mode.

Vibrator

A vibrating motor inside the CX-04 case vibrates for gas alarms and unit malfunctions.

NOTE: If **STEALTH** is set to **ON**, the vibrator only functions when **VIB** in the **STEALTH** Gas Select Mode item is set to **ON** (see page 106).

Sensor

Only one sensor is needed to detect CO and O₂. The dual CO/O₂ sensor is a combination electrochemical cell that consists of two precious metal electrodes in a dilute acid electrolyte. A gas permeable membrane covers the sensor face and allows gas to diffuse into the electrolyte. The gas reacts in the sensor and produces a current proportional to the concentration of the target gases. The CX-04's circuitry amplifies the current, converts the current to a gas concentration, and displays the concentration on the LCD.

Filters

Charcoal Filter (Black)

A black charcoal filter is placed into a recess in the sensor gasket over the sensor. The charcoal filter disk scrubs H₂S and certain hydrocarbons out of the sample to avoid false CO readings. If false or elevated CO readings are noticed, especially in the presence of H₂S, change the charcoal filter.

Hydrophobic Filter

The white, circular hydrophobic filter fits into a recessed area in the front case and is held in place by the sensor gasket. It prevents water and particulates from entering the instrument.

Infrared Communications Port

An infrared (IR) communications port is located at the top of the instrument, near the LED. Logged data transmits through the port in standard IrDA protocol. A computer's infrared port or an IrDA/USB cable connected to a USB port can be used to download data to the 04 Series Datalogging Program. See the 04 Series Datalogging Program operator's manual for data logging and downloading instructions.

Batteries

2 AAA batteries (alkaline or Ni-MH) power the CX-04. At 25°C alkaline batteries will last at least 4,600 hours (191 days) and Ni-MH batteries will last at least 3,000 hours (125 days). The battery icon in the upper right of the LCD shows remaining battery life.

A low battery warning activates when the CX-04 detects a low battery voltage. The CX-04 sounds a dead battery alarm when battery voltage is too low for Measuring Mode.

WARNING: Use only Duracell MN2400 or PC2400 or Eneloop BK-4MCC batteries to maintain the QPS classification of the CX-04. Use of other batteries will void the QPS classification and may void the warranty. Do not mix old/new or different types of batteries.

AVERTISSEMENT: Utiliser uniquement des piles Duracell MN 2400 ou PC 2400 ou Eneloop BK-4MCC de maintenir la classification QPS de la CX-04. L'utilisation d'autres piles annule la classification QPS et peut annuler la garantie. Ne mélangez pas les anciennes/nouvelles ou différents types de piles.

WARNING: To prevent ignition of a hazardous atmosphere, the batteries must only be changed in an area known to be nonhazardous.

AVERTISSEMENT: Pour éviter l'inflammation d'une atmosphère dangereuse, la batterie ne doit être remplacée que dans une zone non dangereuse.

Standard Accessories

Alligator Clip

An alligator clip installs to 2 spring bars on the rear case. Use the alligator clip to attach the CX-04 to clothing or a belt. Teeth in the alligator clip's jaws prevent slipping. The alligator clip can be rotated to change the instrument's orientation.

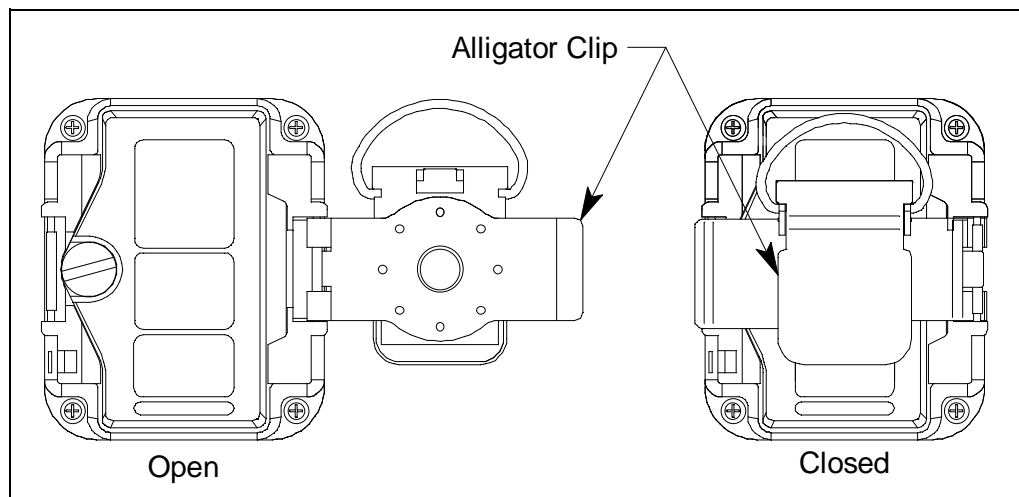

Figure 2: Alligator Clip

Protective Rubber Boot

A protective rubber boot is installed over the CX-04.

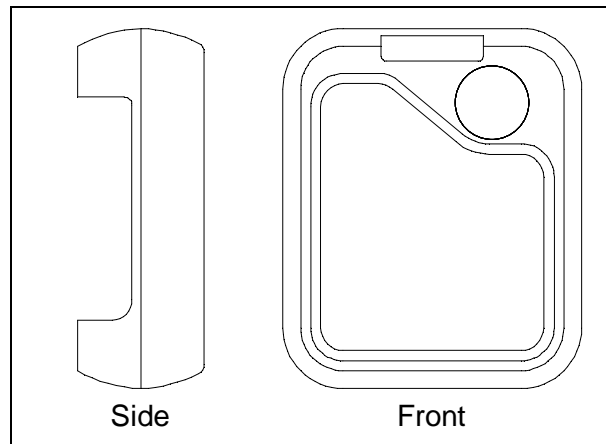

Figure 3: Rubber Boot

Optional Accessories

Belt Clip

The belt clip installs to 2 spring bars on the rear case and is used to easily clip the CX-04 onto a belt.

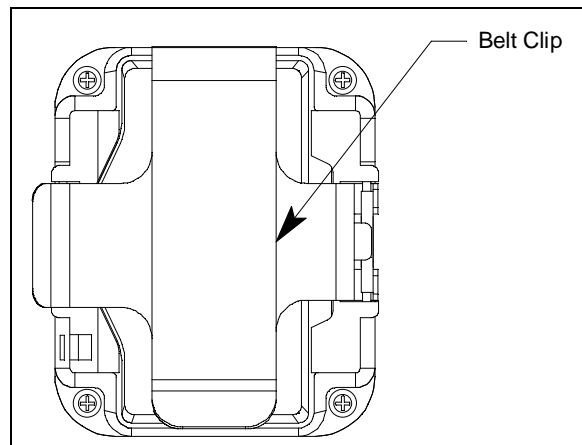

Figure 4: Belt Clip

Wrist Strap

The wrist strap connects to a feature on the back case.

Calibration Cup

The calibration cup installs over the sensor. You must use the calibration cup when performing a bump test, calibration, or gas test.

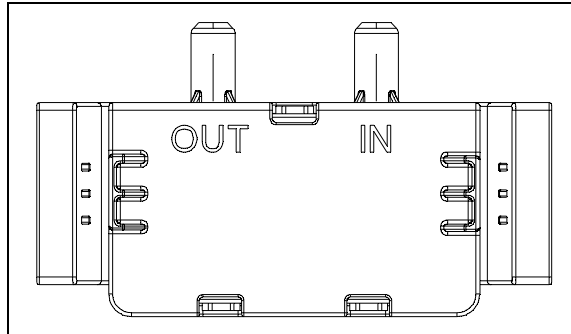

Figure 5: Calibration Cup

IrDA/USB Cable

Unless your computer has a built-in IrDA port, a IrDA/USB cable is needed to establish communication between the CX-04 and the Datalogging Program or the Setup Program.

Chapter 3: Measuring Mode

Overview

This chapter explains how to use the CX-04 to perform confined space entry monitoring or general area monitoring in Measuring Mode.

Start Up

This section explains how to start up the CX-04, get it ready for operation, and turn it off.



Turning On the CX-04

To illustrate certain functions, the following description of the CX-04 start up sequence assumes that the following items in User Mode are turned on: **LUNCH**, **CAL.RMDR**, and **BP.RMDR** in User Mode, and **ID DISP** and **A.ZERO** in Maintenance Mode. If any of these items are turned off, then the corresponding screens do not appear.

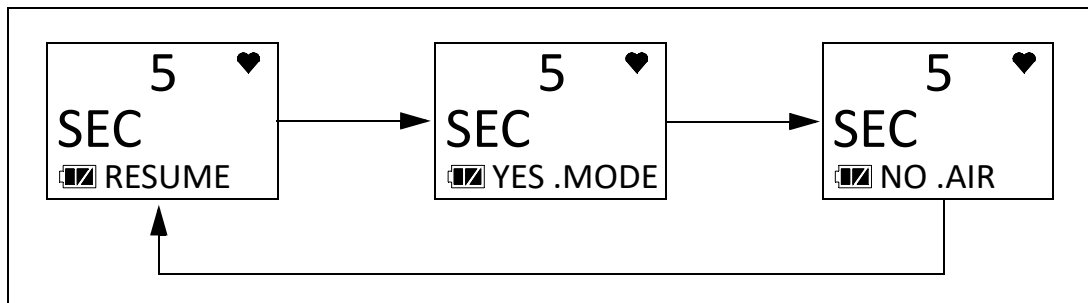
1. Press and briefly hold down POWER MODE. Release the button when you hear a beep.
2. If **LUNCH** is set to **ON** (factory setting if **OFF**, see page 71), the Lunch Break Screen appears. The unit counts down from 5 seconds.

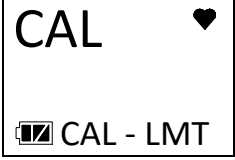

- a. Continue Accumulating: To continue accumulating peak and time-weighted average (TWA) reading (CO only) from the last time the CX-04 was used, press and release POWER MODE or allow the countdown to reach 0. The short-term exposure limit (STEL) reading (CO only) is reset each time the CX-04 is turned on.
 - b. Reset Accumulation: To reset the accumulation of peak and time-weighted average (TWA) reading (CO only), press and release AIR before the countdown reaches 0.
3. If **CAL.RMDR** is set to **ON** (factory setting) and a calibration is due, the screen that appears next depends on how **CAL.EXPD** is set in User Mode (see page 64). The three possible screens are described below. If a calibration is not due, the instrument displays the number of days left until a calibration is due.

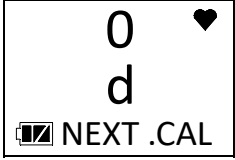
	CAL.EXPD set to CONFIRM (factory setting)	CAL.EXPD set to CANT.USE	CAL.EXPD set to NONE
LCD			
Sound	Buzzer sounds double pulsing tone	Buzzer sounds double pulsing tone	None
Action	<ul style="list-style-type: none"> • <u>Option A, Perform calibration</u>: Press and release POWER MODE to enter User Mode and perform a calibration. The instrument takes you straight to the calibration start screen in User Mode's GAS CAL\A-CAL(E-CAL) item (if Password Protection is set to On using the 04 Series Setup Program, you must enter a password first). See page 49 for calibration instructions. If the calibration is successful, the screen above will not appear again until the unit is due for calibration. If the calibration is not successful, the screen above will again appear in the startup sequence. • <u>Option B, Bypass message</u>: To continue without performing a calibration, press and release AIR. 	<p>The CX-04 cannot be used until a successful calibration is performed. Press and release POWER MODE to enter User Mode and perform a calibration. The instrument takes you straight to the calibration start screen in User Mode's GAS CAL/A-CAL (E-CAL) item (if Password Protection is set to On using the 04 Series Setup Program, you must enter a password first). If you don't press POWER MODE, the instrument automatically goes to the calibration start screen after 6 seconds (if Password Protection is set to On using the 04 Series Setup Program, you must enter a password first). See page 49 for calibration instructions.</p> <p>If the calibration is successful, the screen above will not appear again until the unit is due for calibration. If the calibration is not successful, the screen above will again appear in the startup sequence.</p>	<ul style="list-style-type: none"> • <u>Option A, Perform calibration</u>: If you want to enter User Mode and perform a calibration, press and release POWER MODE. The instrument takes you straight to the calibration start screen in User Mode's GAS CAL/A-CAL (E-CAL) item (if Password Protection is set to On using the 04 Series Setup Program, you must enter a password first). • <u>Option B, Bypass message</u>: To continue without performing a calibration, wait a few seconds for the instrument to continue with its startup sequence.

4. If **BP.RMDR** is set to **ON** (factory setting is **OFF**) and a bump test is due, the screen that appears next depends on how **BP.EXPD** is set in User Mode (see page 68). The three possible screens are described below. If a bump test is not due, the instrument displays the number of days left until a bump test is due.

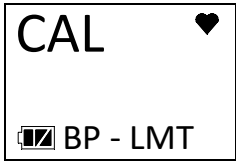
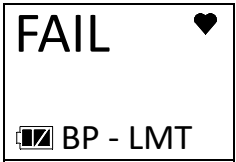
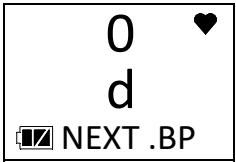
	BP.EXPD set to CONFIRM (factory setting)	BP.EXPD set to CANT.USE	BP.EXPD set to NONE
LCD			
Sound	Buzzer sounds double pulsing tone	Buzzer sounds double pulsing tone	None
Action	<ul style="list-style-type: none"> • <u>Option A, Perform bump test</u>: Press and release POWER MODE to enter User Mode and perform a bump test. The instrument takes you straight to the bump test start screen in User Mode's BUMP item (if Password Protection is set to On using the 04 Series Setup Program, you must enter a password first). See page 43 for bump test instructions. If the bump test is successful, the screen above will not appear again until the unit is due for bump testing. If the bump test is not successful, the screen above will again appear in the startup sequence. • <u>Option B, Bypass message</u>: To continue without performing a bump test, press and release AIR. 	<p>The CX-04 cannot be used until a successful bump test is performed. Press and release POWER MODE to enter User Mode and perform a bump test. The instrument takes you straight to the bump test start screen in User Mode's BUMP item (if Password Protection is set to On using the 04 Series Setup Program, you must enter a password first). If you don't press POWER MODE, the instrument automatically goes to the bump test start screen after 6 seconds (if Password Protection is set to On using the 04 Series Setup Program, you must enter a password first). See page 43 for bump test instructions.</p> <p>If the bump test is successful, the screen above will not appear again until the unit is due for bump testing. If the bump test is not successful, the screen above will again appear in the startup sequence.</p>	<ul style="list-style-type: none"> • <u>Option A, Perform bump test</u>: If you want to enter User Mode and perform a bump test, press and release POWER MODE. The instrument takes you straight to the bump test start screen in User Mode's BUMP item (if Password Protection is set to On using the 04 Series Setup Program, you must enter a password first). • <u>Option B, Bypass message</u>: To continue without performing a bump test, wait a few seconds for the instrument to continue with its startup sequence.

- The Date/Time Screen appears for a few seconds.

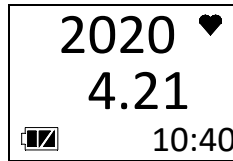

- The Battery Voltage Screen appears for a few seconds. An “AL-L” at the bottom of the screen indicates that the alarms are set to latching. An “AL-A” at the bottom of the screen indicates that the alarms are set to auto reset. See page 97 for a description of how to change this parameter.

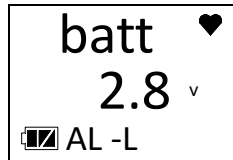

- The following screens display for 1 second each: Gas Name, Full Scale, Warning Setpoint, Alarm Setpoint, Alarm H Setpoint, STEL Setpoint (CO only), and TWA Setpoint (CO only).

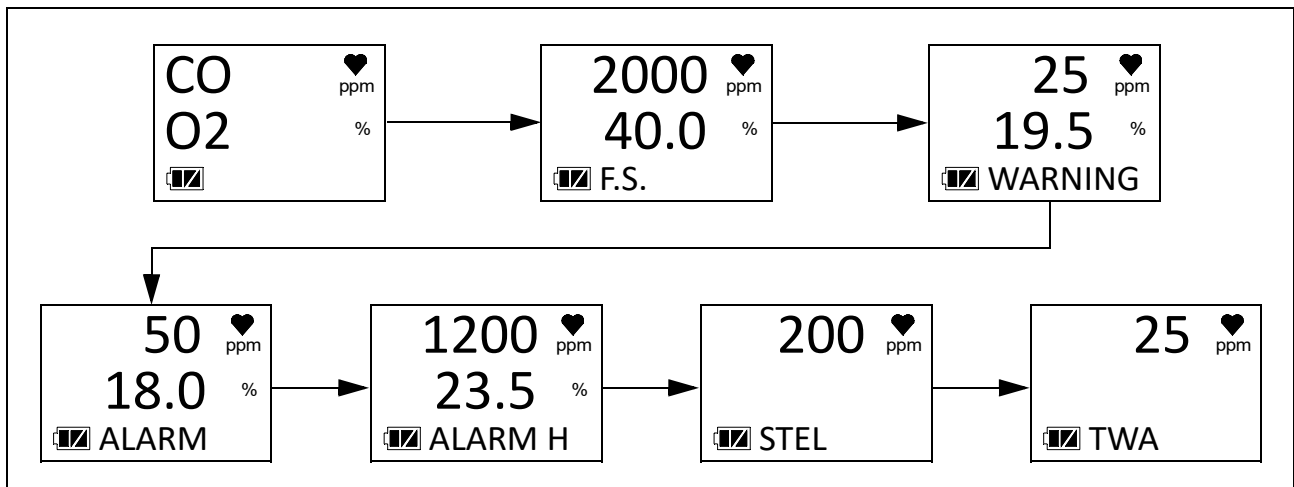

- If **ID DISP** is set to **ON** (factory setting is **OFF**, see page 98), the User ID Screen appears for a few seconds, followed by the Station ID Screen.

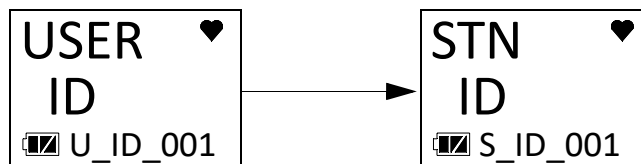

- If the CX-04 experiences a sensor failure during start up, a screen indicating that the sensor failed appears and the buzzer sounds a double pulsing tone once per second.

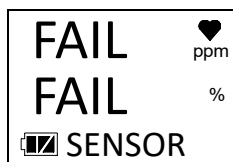

You cannot acknowledge the failure and continue to Measuring Mode. Replace the failed sensor as soon as possible.

WARNING: *If A.ZERO is set to ON (factory setting is OFF, see page 98), the instrument prompts you to do an auto zero. An auto zero operation sets the CO reading to 0 ppm and the O₂ reading to 20.9% volume.*

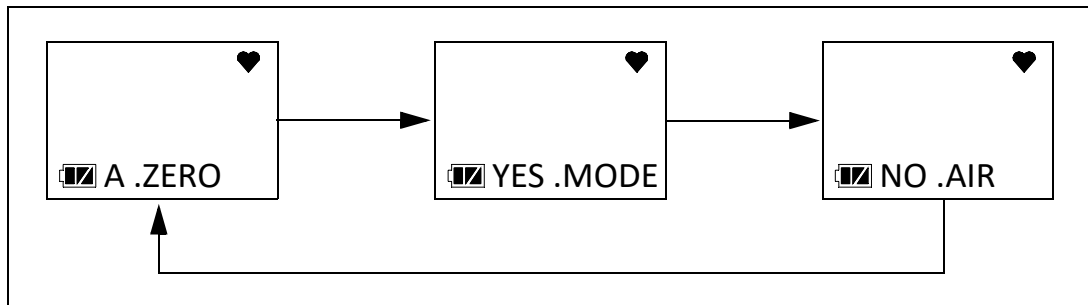

WARNING: *Make sure that the instrument is in a known fresh air environment (an environment free of combustible or toxic gases and of normal oxygen content, 20.9%) before performing an auto zero operation. If you perform an auto zero operation in an area with gases present, the adjustment will not be accurate.*

You must press and release the POWER MODE button to perform an auto zero function. If you do not press any key, after 15 seconds, the instrument enters Measuring Mode without performing an auto zero.

If **Password Protection** is turned **On** (factory setting is **Off**) using the 04 Series Setup Program, a user-set password is required to perform an auto zero. When the password screen appears, adjust each digit with the AIR button and press and release the POWER MODE button to move on to the next digit. Once the password is entered, the instrument performs the auto zero.

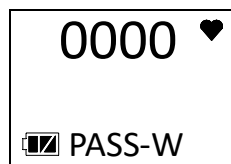

10. The CX-04 is now monitoring for gas in Measuring Mode. The Measuring Mode Screen displays the current gas readings.

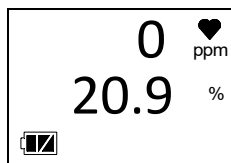

Performing a Demand Zero

Perform a demand zero before using the CX-04. This sets the CO reading to 0 ppm and the O₂ reading to 20.9% volume.

1. Find a fresh-air environment. This is an environment free of toxic or combustible gases and of normal oxygen content (20.9%).
2. Turn on the unit as described above in Turning On the CX-04.
3. Press and hold AIR. The buzzer pulses and the LCD prompts you to continue holding AIR (if **KEY.TONE** is set to **ON** in User Mode).
4. Continue to hold AIR until the LCD prompts you to release it. The CX-04 sets the fresh air reading. Start up is complete and the unit is now ready for monitoring.
5. If **Password Protection** is turned **On** (factory setting is **Off**) using the 04 Series Setup Program, a user-set password is required to perform a demand zero. When the password screen appears, adjust each digit with the AIR button and press and release the POWER MODE button to move on to the next digit. Once the password is entered, the instrument sets the fresh air reading.

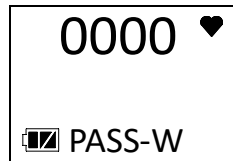

Turning Off the CX-04

1. Press and hold POWER MODE.
2. OFF appears on the display and the buzzer pulses for about five seconds (if **KEY.TONE** is set to **ON** in User Mode).
3. Release the button when OFF disappears from the display.
4. If **Password Protection** is turned **On** (factory setting is **Off**) using the 04 Series Setup Program, a user-set password is required to turn off the CX-04. When the password screen appears, adjust each digit with the AIR button and press and release the POWER MODE button to move on to the next digit. Once the password is entered, the instrument shuts off.

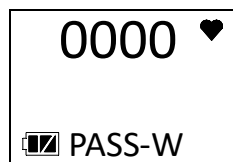

Measuring Mode Operation

When the CX-04 completes its startup sequence, it is in Measuring Mode. In Measuring Mode the CX-04 continuously monitors the sampled atmosphere and displays the gas concentrations. The CX-04 is in Normal Operation if there are no alarm indications.

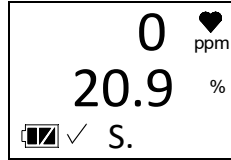

Heart Symbol: The heart symbol in the top right corner of the LCD indicates the operation status and flashes when normal. A microprocessor error causes the heart symbol to stop flashing or to disappear.

Check Mark: If **BP.RMDR** is set to **ON** and if a bump test is not due, a check mark appears in the lower left corner of the LCD.

“S”: If the instrument is operating in Stealth Mode, an “S.” appears at the bottom of the LCD.

Backlight: In a low-light environment, press and release either button to turn on the display backlight. See page 73 to program backlight duration.

Confirmation/Non-Compliance Indicator: If the **BEEP** item in User Mode is set to anything other than **OFF**, the CX-04 gives periodic indications to confirm that it’s operating or to indicate a non-compliance (see page 72).

Monitoring an Area

1. Start up the CX-04 as described above in “Start Up” on page 17. It is now in Measuring Mode.

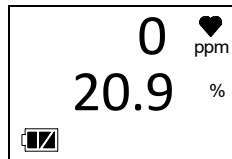

2. The instrument displays the CO reading on the top line and the O₂ reading on the bottom line.
3. Take the CX-04 to the monitoring area.
4. Wait at least 15 seconds.
5. If a reading is observed, allow the reading to stabilize to determine the gas concentration present.
6. If a gas alarm occurs, take appropriate action. See page 26.

Alarms

This section covers alarm indications in Measuring Mode. It also describes how to reset the CX-04 after an alarm occurs and how to respond to an alarm condition.

NOTE: False alarms may be caused by radio frequency (RF) or electromagnetic (EMI) interference. Keep the CX-04 away from RF and EMI sources such as radio transmitters or large motors.

Alarm Indications

The CX-04 buzzer sounds an alarm, the LED flashes, and the vibrator pulses when any sort of alarm condition or failure occurs. If the CX-04 is operating in Stealth Mode, the buzzer does not sound and the vibrator's operation depends on the **VIB** setting in Gas Select Mode's **STEALTH** item. See page 106 for more information.

NOTE: If an alarm condition occurs while you are in Display Mode, the CX-04 automatically returns to the Measuring Mode screen.

The table below summarizes the types of alarms produced by the CX-04 and their indications.

Table 4: Alarm Types and Indications

Alarm Type	Visual Indications	Other Indications
Warning Concentration of gas rises above the Warning setting.	<ul style="list-style-type: none">• Gas reading flashes• WARNING appears at the bottom of the LCD• Alarm LED flashes once per second• Backlight turns on	<ul style="list-style-type: none">• High-low tone sounds once per second• Vibrator pulses once per second
Alarm Concentration of gas rises above the Alarm setting.	<ul style="list-style-type: none">• Gas reading flashes• ALARM appears at the bottom of the LCD• Alarm LED flashes twice per second• Backlight turns on	<ul style="list-style-type: none">• High-low tone sounds twice per second• Vibrator pulses twice per second
Alarm H Concentration of gas rises above the Alarm H setting.	<ul style="list-style-type: none">• Gas reading flashes• ALARM H appears at the bottom of the LCD• Alarm LED flashes twice per second• Backlight turns on	<ul style="list-style-type: none">• High-low tone sounds twice per second• Vibrator pulses twice per second

Table 4: Alarm Types and Indications

Alarm Type	Visual Indications	Other Indications
TWA or STEL (CO Only) Concentration rises above the TWA or STEL alarm setting.	<ul style="list-style-type: none"> • Gas reading flashes • TWA or STEL appears at the bottom of the LCD • Alarm LED flashes once per second • Backlight turns on 	<ul style="list-style-type: none"> • High-low tone sounds once per second • Vibrator pulses once per second
Over Range	<ul style="list-style-type: none"> • Gas reading is replaced with a flashing □□□ • Gas name and units flash • OVER appears at the bottom of the LCD • Alarm LED flashes twice per second • Backlight turns on 	<ul style="list-style-type: none"> • High-low tone sounds twice per second • Vibrator pulses twice per second
Minus Over Range	<ul style="list-style-type: none"> • Affected channel's gas reading is replaced with a flashing "- - -" • Gas name and units flash • MOVER appears at the bottom of the LCD • Alarm LED flashes twice per second • Backlight turns on 	<ul style="list-style-type: none"> • High-low tone sounds twice per second • Vibrator pulses twice per second
Low Battery Warning	<ul style="list-style-type: none"> • The last bar in the battery icon starts flashing 	None
Dead Battery Alarm	<ul style="list-style-type: none"> • Gas reading disappears. FAIL BATTERY appears on the LCD. • Alarm LED flashes once per second 	Double pulsing tone sounds once per second
Sensor Failure	<ul style="list-style-type: none"> • FAIL SENSOR appears on the LCD. • Alarm LED flashes once per second 	Double pulsing tone sounds once per second
Clock Failure	<ul style="list-style-type: none"> • FAIL 050 CLOCK appears on the LCD • Alarm LED flashes once per second 	Double pulsing tone sounds once per second

Table 4: Alarm Types and Indications

Alarm Type	Visual Indications	Other Indications
System Failure	<ul style="list-style-type: none"> • FAIL SYSTEM and an error code appear on the LCD • Alarm LED flashes once per second 	Double pulsing tone sounds once per second

Responding to Alarms

This section describes response to gas, over range, battery, sensor failure, clock failure, and system failure alarms.

Responding to Gas Alarms

1. Follow your established procedure for an increasing gas condition.
2. Reset the alarm as necessary or allowed.
 - a. If **LATCH** is set to **ON** (factory setting) in Maintenance Mode, the gas reading must fall below an alarm setting before you can reset the alarm condition using **POWER MODE** or **AIR**.

If **Password Protection** is turned **On** (factory setting is **Off**) using the 04 Series Setup Program, you must press **POWER MODE** and **AIR** at the same time and then enter a user-set password to reset an alarm condition. When the password screen appears, adjust each digit with the **AIR** button and press and release the **POWER MODE** button to move on to the next digit. Once the password is entered, the alarm condition resets.

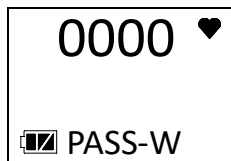

- b. If **LATCH** is set to **OFF** in Maintenance Mode, the alarm condition automatically resets when gas reading falls below an alarm setpoint.

Responding to Over Range Alarms

WARNING: *An over range condition may indicate an extreme carbon monoxide concentration or an explosive concentration. Confirm the gas concentration with a different CX-04 or with another gas detecting device.*

AVERTISSEMENT: *Un dépassement de la plage peut indiquer une concentration extrême en monoxyde de carbone ou une concentration en explosif. Confirmez la concentration de gaz avec un CX-04 différent ou avec un autre dispositif de détection de gaz.*

1. Follow your established procedure for an extreme gas condition.

2. Reset the alarm using POWER MODE or AIR once the alarm condition clears if **LATCH** is set to **ON** (factory setting) in Maintenance Mode.

If **Password Protection** is turned **On** (factory setting is **Off**) using the 04 Series Setup Program, you must press POWER MODE and AIR at the same time and then enter a user-set password to reset an alarm condition. When the password screen appears, adjust each digit with the AIR button and press and release the POWER MODE button to move on to the next digit. Once the password is entered, the alarm condition resets.

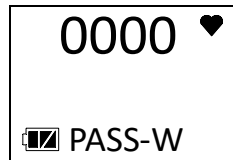

3. Calibrate the CX-04 as described on page 49.
4. If the over range condition continues or if you are not able to successfully calibrate the unit, you may need to replace the sensor.
5. If the over range condition continues after you replace the sensor, contact RKI Instruments, Inc. for further instructions.

Responding to Battery Alarms

WARNING: *The CX-04 is not operational as a gas monitoring device during a dead battery alarm. Take the CX-04 to a non-hazardous area and replace the batteries as described in “Replacing the Batteries (Alkaline or Ni-MH)” on page 80.*

The CX-04 is fully functional during a low battery warning. However, only a couple of days of operating time remain. The amount of time depends on LCD backlight use and alarm frequency. Replace the batteries as described on page 80 as soon as possible.

NOTE: Alarms and the LCD backlight consume battery power and reduce the amount of operating time remaining.

Responding to Sensor Failure Alarms

1. Calibrate the sensor as described on page 49.
2. If the sensor failure continues, replace the sensor as described on page 87.
3. If the sensor failure condition continues after replacing the sensor, contact RKI Instruments, Inc. for further instructions.

Responding to Clock Failure Alarms

A clock failure alarm occurs if the unit's internal clock malfunctions.



1. Press and release POWER MODE to continue into Measuring Mode.

CAUTION: *There is no datalogging function if you operate the instrument after a clock failure.*

2. Attempt to set the date using the **DATE** item in User Mode (see page 76).
3. If the date cannot be set correctly, contact RKI Instruments, Inc. as soon as possible.

Responding to System Failure Alarms

1. If a system failure occurs, the system failure screen displays an error code as shown below:



2. The error code meanings are shown in the table below:

Table 5: Error Code Explanation

Error Code	Explanation
000	ROM failure
010	RAM failure
020	FRAM failure
031	FLASH memory failure
082	Temperature sensor failure

3. If the error code is anything but 031, the instrument cannot be used. Contact RKI Instruments, Inc. as soon as possible.

If the error code is 031, press and release POWER MODE to continue into Measuring Mode if the instrument must be used temporarily.

CAUTION: *There is no datalogging function if you operate the instrument after a 031 system failure. Contact RKI Instruments, Inc. as soon as possible.*

Data Logging

The CX-04 logs Measuring Mode gas readings, alarm data, and calibration data to its internal memory. Logged data can be download it to a computer via the infrared communications port on the front of the unit.

The data logging capacity depends on how often the CX-04 stores data and how often the CX-04 is turned on and off. The table below illustrates how much data logging time is available for the various interval times. It assumes that the unit is only turned on once and there are no alarms. The data logging interval time must be set using the 04 Series Datalogging Program.

Table 6: Data Logging Capacity

Interval Time	Data Logging Capacity
10 seconds	10 hours
20 seconds	20 hours
30 seconds	30 hours
1 minute	60 hours
3 minutes	180 hours
5 minutes	300 hours
10 minutes	600 hours

To utilize the CX-04's downloading capability, you need:

- PC with Windows 7, Windows 8, Windows 10, or Windows 11
- IrDA port or IrDA/USB cable (cable available from RKI Instruments, Inc.)
- 04 Series Datalogging Program (available at www.rkiinstruments.com/04series).

For a complete description of the Datalogging Program and procedures for downloading data to a computer, see the 04 Series Datalogging Program Operator's Manual.

Chapter 4: Display Mode

This section describes Display Mode which is accessible from Measuring Mode. See Table 7 below for a list of Display Mode's menu items, a short description of each item, and the page number for further description.

Table 7: Display Mode Menu Items

Display Mode Menu Item	Description
Gas Name (page 31)	Displays the gas name for each line of readings.
PEAK (page 31)	Displays the Peak reading.
STEL (page 32)	Displays the STEL reading (CO only).
TWA (page 32)	Displays the TWA reading (CO only).
USER ID (page 32) ^A	View and/or change the User ID.
STN ID (page 33) ^A	View and/or change the Station ID.
CAL.DATA (page 34) ^B	Displays the last calibration date.
BP.DATA (page 35) ^C	Displays the last bump test date.
DATE (page 35)	Displays the current date and time.
TEMP (page 35)	Displays the current temperature.
ALARM--P (page 36)	View alarm points.
BUZZ.VOL (page 37) ^D	Set the buzzer volume to LO or HI (factory setting).
<p>^A Only appears if DISP.SET is set to ON in User Mode (factory setting) <u>and</u> if ID DISP is set to ON in Maintenance Mode (factory setting is OFF).</p> <p>^B Only appears if CAL.RMDR is set to ON in User Mode (factory setting).</p> <p>^C Only appears if BP.RMDR is set to ON in User Mode (factory setting is OFF).</p> <p>^D Only appears if DISP.SET is set to ON in User Mode (factory setting).</p>	

Tips for Using Display Mode

- To enter Display Mode and scroll from one item to the next or skip an item when a question is asked, press and release POWER MODE.
- To enter an item, press and release AIR.
- To change a flashing parameter, press and release AIR. To reverse the movement in a list (ie. from down to up or vice versa):
 - a. Press and hold AIR.
 - b. Immediately press POWER MODE and then release both buttons.
- To exit from an entered-information screen and go back to Measuring Mode, press and release POWER MODE until you get to the Measuring Mode screen.

NOTE: Each screen displays for 20 seconds. If you do not press a button within 20 seconds, the CX-04 automatically returns to Measuring Mode.

Gas Name Screen

The gas name screen shows the gas name and units for each line of readings.



Peak Screen (PEAK)

The peak screen displays the highest concentration (lowest concentration for O₂) detected since the CX-04 was turned on. The peak reading is stored until a higher level is detected, the peak reading is cleared, or the CX-04 is turned off.

The lunch break feature enables the CX-04 to save the peak reading when it is turned off so it can continue with the same peak when it is turned on again (see page 17).

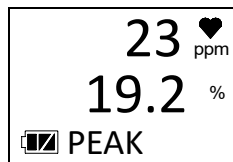

To clear the peak reading, do the following:

NOTE: If **Password Protection** is set to **On** using the 04 Series Setup Program, the peak reading cannot be cleared.

1. After entering Display Mode, press and release POWER MODE until **PEAK** appears.

2. Press and hold AIR until the screen prompts you to release it.

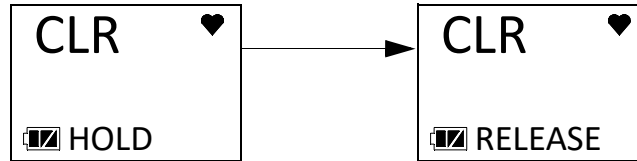

3. The peak reading is reset and the unit returns to the Peak Screen.

If you do not want to clear the peak reading, release AIR before the above screen sequence occurs. The unit returns to the Peak Screen.

STEL Screen (STEL)

The STEL Screen displays the short term exposure limit (STEL) reading for the CO channel only. The STEL reading is the average reading *over the last 15 minutes*.

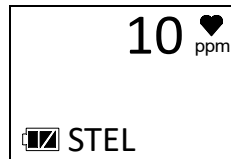

TWA Screen (TWA)

The TWA Screen displays the time weighted average (TWA) reading for the CO channel only.

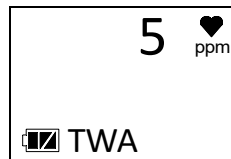

The TWA reading is the average reading *over the last 8 hours*. If 8 hours have not elapsed since the last time the TWA reading was cleared, the average is still calculated over 8 hours. The missing readings are assigned a value of 0. If **LUNCH** is set to **OFF** (factory setting), the TWA is cleared when the CX-04 is turned off.

If **LUNCH** is set to **ON**, the CX-04 remembers the TWA reading when it is turned off and can continue accumulation when it is turned on again (see page 17).

Changing the User ID (USER ID)

This screen only appears if **DISP.SET** in User Mode is set to **ON** (factory setting) and if **ID DISP** in Maintenance Mode is set to **ON** (factory setting is **OFF**).

Use this screen to select a user ID from the 128 user IDs that are stored in the CX-04's memory. Before a user ID is selected on a brand new instrument, the user ID is "-----". The factory-installed user IDs have a "U_ID_XXX" format.

The user ID provides a way to identify the CX-04 user during a data logging session.

User IDs can only be selected in this menu item. In order to edit the 128 user IDs, you must use the 04 Series Datalogging Program or 04 Series Setup Program.

1. After entering Display Mode, press and release POWER MODE until the **USER ID** screen sequence appears.

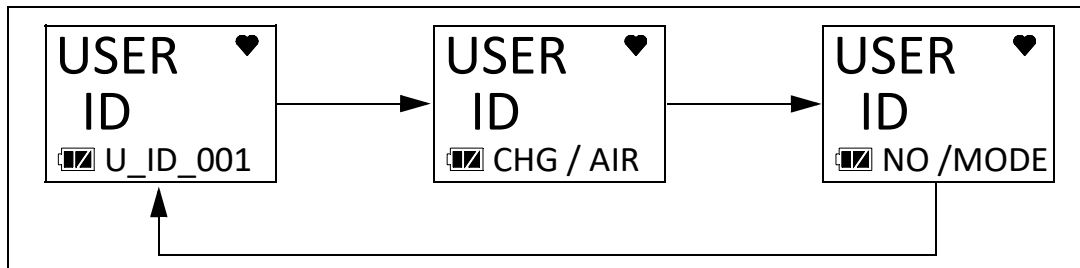

2. To change the User ID, press and release AIR. The current User ID flashes.

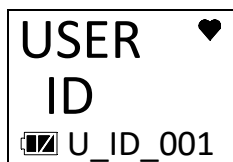

3. Use AIR to scroll to the desired User ID.
4. Press and release POWER MODE to save the User ID and return to the **USER ID** screen in Display Mode.

Changing the Station ID (STN ID)

This screen only appears if **DISP.SET** in User Mode is set to **ON** (factory setting) and if **ID DISP** in Maintenance Mode is set to **ON** (factory setting is **OFF**).

Use this screen to select a station ID from the 128 station IDs that are stored in the CX-04's memory. Before a station ID is selected on a brand new instrument, the station ID is "-----". The factory-installed station IDs have a "S_ID_XXX" format.

The station ID provides a way to identify the CX-04 location during a data logging session.

User IDs can only be selected in this menu item. In order to edit the 128 user IDs, you must use the 04 Series Datalogging Program or 04 Series Setup Program.

1. After entering Display Mode, press and release POWER MODE until the **STN ID** screen sequence appears.

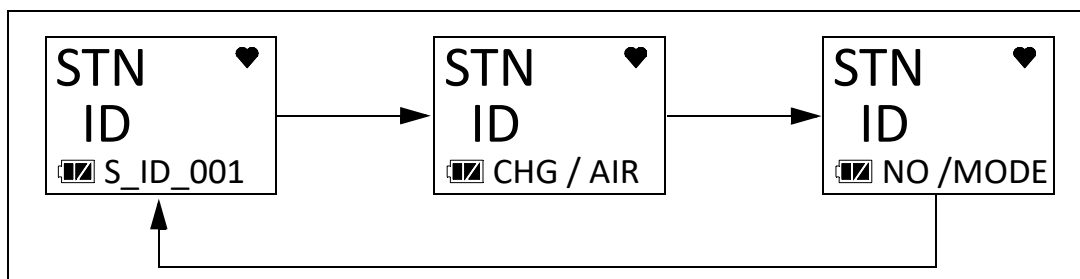

- To change the Station ID, press and release AIR. The current Station ID flashes.

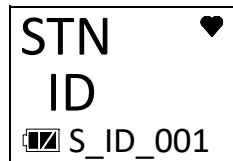

- Use AIR to scroll to the desired Station ID.
- Press and release POWER MODE to save the Station ID and return to the **STN ID** screen in Display Mode.

Last Successful Calibration Date (CAL.DATA)

The **CAL.DATA** screen shows the date of the last successful calibration. This screen only appears if **CAL.RMDR** is set to **ON** (factory setting).

- After entering Display Mode, press and release POWER MODE until the **CAL.DATA** screen sequence appears.

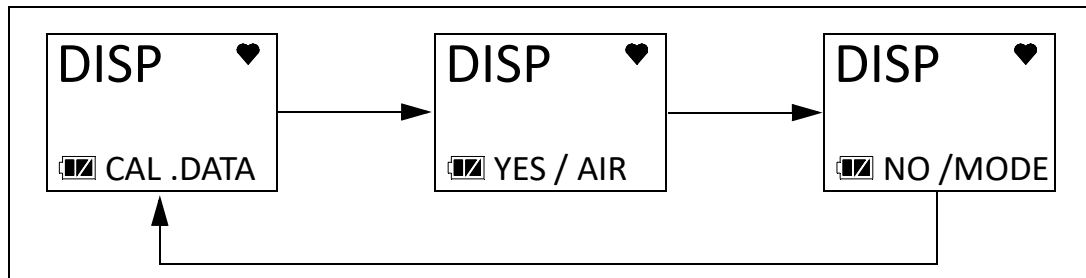

- Press AIR to enter the **CAL.DATA** screen and switch between the channels.

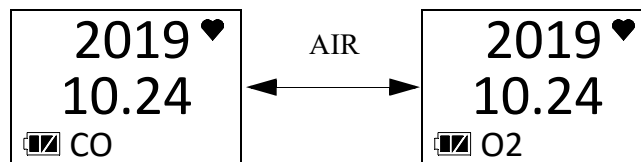

- Press and release POWER MODE to return to the **CAL.DATA** screen in Display Mode.

Last Successful Bump Test Date (BP.DATA)

The **BP.DATA** screen shows the date of the last successful bump test. This screen only appears if **BP.RMDR** is set to **ON** (factory setting is **OFF**).

1. After entering Display Mode, press and release **POWER MODE** until the **BP.DATA** screen sequence appears.

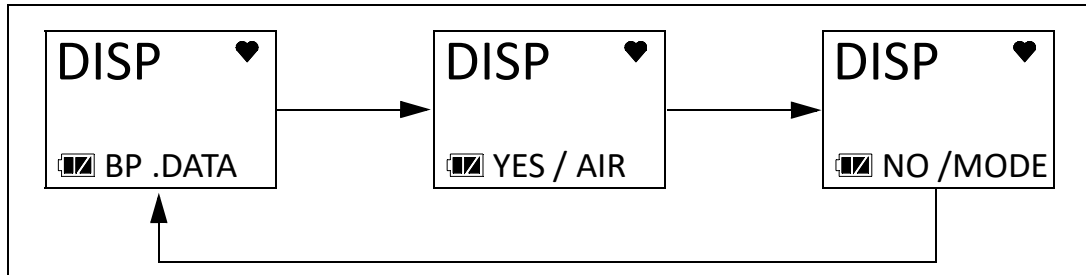

2. Press **AIR** to enter the **BP.DATA** screen and switch between the channels.

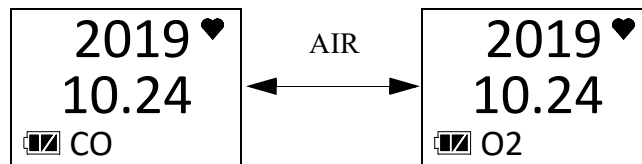

3. Press and release **POWER MODE** to return to the **BP.DATA** screen in Display Mode.

Date/Time Screen (DATE)

The **DATE** screen shows the instrument's date and time.

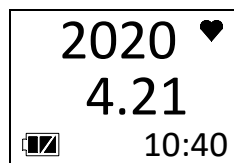

Temperature Screen (TEMP)

The **TEMP** screen shows the surrounding area's temperature.

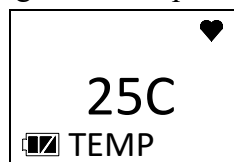

Alarm Points Screen (ALARM--P)

The Alarm Points Screen shows the gas alarm settings.

1. After entering Display Mode, press and release POWER MODE until the **ALARM--P** screen sequence appears.

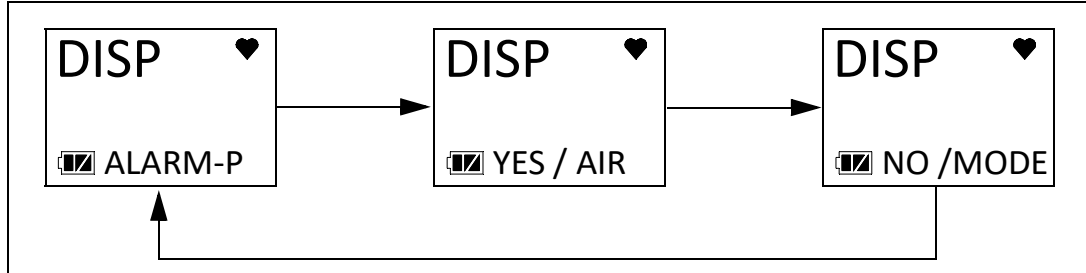

2. Press and release AIR. The Full Scale Setting screen appears.
3. Use AIR to scroll through the Warning, Alarm, Alarm H, STEL (CO only), and TWA (CO only) settings.

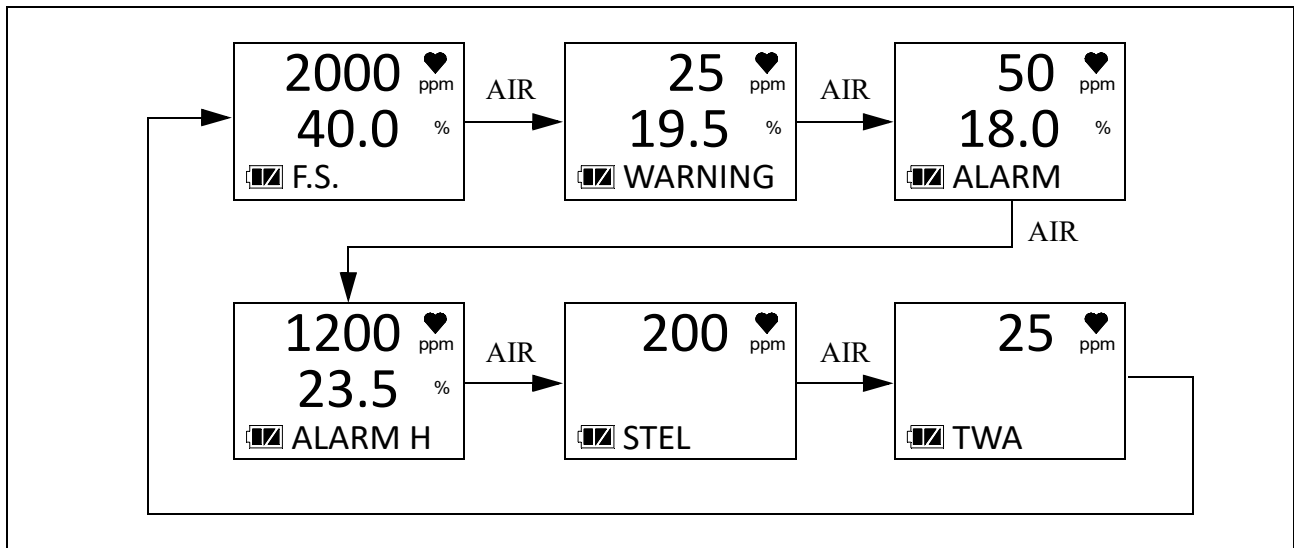

4. While viewing the alarm settings for a particular alarm point, press and release AIR and POWER MODE at the same time to simulate the alarm conditions. The buzzer will sound, the LED will flash, and the instrument will vibrate just as it would if the displayed condition was actually happening.
5. Press and release POWER MODE to return to the Alarm Points Screen.

Adjusting the Buzzer Volume (BUZZ.VOL)

The **BUZZ.VOL** screen allows you to adjust the volume of the instrument's buzzer. This screen only appears if **DISP.SET** in User Mode is set to **ON** (factory setting).

HI (factory setting): Buzzer volume is high.

LO: Buzzer volume is low.

1. While in Display Mode, press and release **POWER MODE** until **BUZZ.VOL** appears. The current setting displays on the top line.

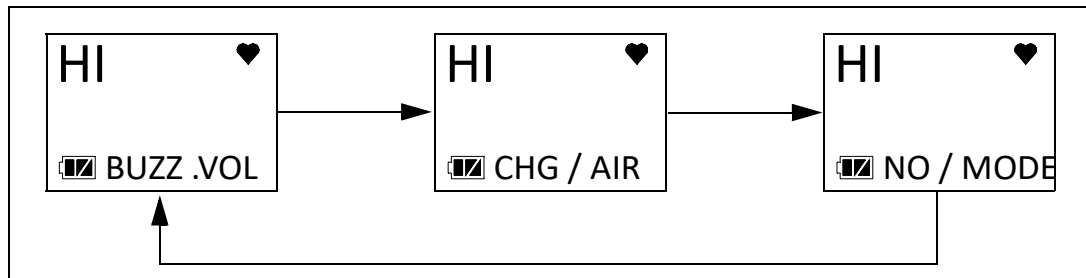

2. Press and release **AIR**. The current setting flashes.
3. Use **AIR** to display the desired setting.
4. Press and release **POWER MODE** to save the setting and return to the **BUZZ.VOL** item in Display Mode.

Chapter 5: User Mode and Calibration

Overview

This section describes the CX-04 in User Mode. See Table 8 below for a list of the items found in User Mode, the page that the item's instructions can be found on, and a short description of the item.

Table 8: User Mode Menu Items

User Mode Menu Item	Description			
BUMP (page 43)	Perform a bump test.			
	BUMP CYL X	Perform a bump test on the gas selected for Cylinder X (Cylinders A-E available).		
	START	Begin the warmup sequence and enter Measuring Mode.		
	ESCAPE	Return to the BUMP menu item.		
GAS CAL (page 49)	Perform a fresh air adjustment, perform a span adjustment, change the calibration gas concentration.			
	AIR (page 49)	Perform a fresh air adjustment.		
	A-CAL (page 50) or E-CAL (page 55) depending on E-CAL User Mode setting	A-CAL (or E-CAL) CYL X	Perform a span adjustment on the gas selected for Cylinder X (Cylinders A-E available).	
		START	Begin the warmup sequence and enter Measuring Mode.	
		CAL-P	Set the calibration gas concentration.	
		CYL SEL	Assign a cylinder (A-E) to each gas. CO and O ₂ are assigned to Cylinder A by default.	
	ESCAPE	Return to the A-CAL item in the GAS CAL menu.		
ESCAPE	Return to the GAS CAL item in User Mode.			

Table 8: User Mode Menu Items

User Mode Menu Item	Description		
CAL SET (page 63)	Change parameters related to calibration.		
	CAL.RMDR (page 63)	<p><u>ON (factory setting)</u>: The instrument notifies the user upon startup when a calibration is due. Notification type depends on CAL.EXPD setting below. CAL.DATA screen appears in Display Mode.</p> <p><u>OFF</u>: No notification upon startup when a calibration is due. CAL.DATA screen does not appear in Display Mode.</p>	
	CAL.INT (page 64)	<p>How often the instrument needs to be calibrated.</p> <p>Options: 1 - 1000 days (factory setting is 90 days)</p>	
CAL SET (cont'd)	CAL.EXPD (page 64)	<p>Defines what action must be taken if a calibration is due upon startup.</p> <p><u>CONFIRM (factory setting)</u>: Press and release AIR to acknowledge that calibration is due and continue to Measuring Mode.</p> <p><u>CANT.USE</u>: Cannot enter Measuring Mode until a successful calibration is performed.</p> <p><u>NONE</u>: A screen indicates that calibration is due but warmup sequence continues.</p>	
	ESCAPE	Return to the CAL SET item in User Mode.	
BUMP.SET (page 65)	Change parameters related to bump testing.		
	SETTING (page 65)	GAS.TIME	<p>How long gas is applied during a bump test.</p> <p>Choices: 30 (factory setting), 45, 60, 90 seconds</p>
		CHECK	<p>Percentage of calibration gas concentration that the bump test reading must be within in order to pass bump.</p> <p>Options: 10%, 20%, 30%, 40%, 50% (factory setting)</p>
		CAL.TIME	<p>How long gas is applied during a calibration.</p> <p>GAS.TIME is deducted from this time.</p> <p>Options: 90 (factory setting) or 120 seconds</p>
		A-CAL	<p><u>ON (factory setting)</u>: If a bump test fails, a calibration automatically starts.</p> <p><u>OFF</u>: If a bump test fails, a calibration does not automatically start.</p>
		ESCAPE	Return to the SETTING item in the BUMP SET menu.

Table 8: User Mode Menu Items

User Mode Menu Item	Description	
BUMP.SET (page 65) cont.	BP.RMDR (page 68)	<p><u>ON</u>: The instrument notifies the user upon startup when a bump test is due. Notification type depends on BP.EXPD setting below. BP.DATA screen appears in Display Mode.</p> <p><u>OFF (factory setting)</u>: No notification upon startup when a bump test is due. BP.DATA screen does not appear in Display Mode.</p>
	BP.INT (page 68)	<p>How often the instrument needs to be bump tested.</p> <p>Options: 0 - 30 days (factory setting is 30 days)</p>
	BP.EXPD (page 68)	<p>Defines what action must be taken if a bump test is due upon startup.</p> <p><u>CONFIRM (factory setting)</u>: Press and release AIR to acknowledge that bump test is due and continue to Measuring Mode.</p> <p><u>CANT.USE</u>: Cannot enter Measuring Mode until a successful bump test is performed.</p> <p><u>NONE</u>: A screen indicates that bump test is due but warmup sequence continues.</p>
	ESCAPE	<p>Return to the BUMP SET item in User Mode.</p>
ALARM-P (page 69)	<p>Set alarm points (WARNING, ALARM, ALARM H, STEL, TWA) and/or reset all alarms to their default settings.</p>	
LUNCH (page 71)	<p><u>ON</u>: Lunch break feature is on. Instrument asks if you want to resume TWA (CO only) and PEAK readings at startup.</p> <p><u>OFF (factory setting)</u>: Lunch break feature is off. Instrument resets TWA (CO only) and PEAK readings every time it's turned on.</p>	

Table 8: User Mode Menu Items

User Mode Menu Item	Description	
BEEP (page 72)	BEEP.SEL (page 72)	<p>Set confirmation beep parameters.</p> <p><u>LED</u>: LED flashes and instrument vibrates based on interval defined in BEEP.INT to confirm instrument is still operating.</p> <p><u>BUZZER</u>: Buzzer sounds and instrument vibrates based on interval defined in BEEP.INT to confirm instrument is still operating.</p> <p><u>LED+BUZ</u>: LED flashes, buzzer sounds, and instrument vibrates based on interval defined in BEEP.INT to confirm instrument is still operating.</p> <p><u>BMP/CAL</u>: LED flashes based on interval defined in BEEP.INT if bump test or calibration is due regardless of whether BP.RMDR and/or CAL.RMDR are set to ON.</p> <p><u>OFF (factory setting)</u>: No alerts to confirm instrument is still operating or that a bump test or calibration is due.</p>
	BEEP.INT (page 73)	<p>Confirmation alert interval. Confirmation type defined in BEEP.SEL.</p> <p>Options: 0.5 minute and 1 to 99 minutes in 1 minute increments. The factory setting is 5 minutes.</p>
BEEP (page 72) cont.	ESCAPE	Return to the BEEP item in User Mode.
BL TIME (page 73)	<p>How long the back light stays on after the last button press.</p> <p>Options: 0 - 255 seconds or OFF. The factory setting is 30 seconds.</p>	
KEY.TONE (page 74)	<p><u>ON (factory setting)</u>: Buzzer sounds when button is pressed.</p> <p><u>OFF</u>: Buzzer does not sound when button is pressed.</p>	
DISP.SET (page 74)	<p><u>OFF</u>: USER ID, STN ID, and BUZZ.VOL items do not appear in Display Mode.</p> <p><u>ON (factory setting)</u>: BUZZ.VOL item appears in Display Mode. USER ID and STN ID items appear if ID DISP in Maintenance Mode is also set to ON.</p>	
ZERO.SUP (page 75)*	<p><u>ON (factory setting)</u>: Not intended for field adjustment. The suppression values are:</p> <p>CO: 2 ppm</p> <p>O₂: 0.5% volume</p>	
ZERO.FLW (page 75)**	<p><u>ON (factory setting)</u>: Not intended for field adjustment. Oxygen channel does not support zero follower functionality.</p>	
E-CAL (page 75)	<p><u>XX seconds</u>: E-CAL appears in GAS CAL instead of A-CAL.</p> <p><u>OFF (factory setting)</u>: E-CAL does not appear in GAS CAL.</p>	
DATE (page 76)	Set the instrument's date and time.	
PASS-W (page 76)	<p><u>ON</u>: User Mode is password-protected. Factory-set password is 0405.</p> <p><u>OFF (factory setting)</u>: User Mode is not password-protected.</p>	

Table 8: User Mode Menu Items

User Mode Menu Item	Description
ROM/SUM (page 77)	View the firmware information for the CX-04's sensor board and main board.
START (page 77)	Press and release POWER MODE to begin the warmup sequence and enter Measuring Mode.
<p>* Only appears if ZSUP.DSP is set to ON in Maintenance Mode. ** Only appears if ZFLW.DSP is set to ON in Maintenance Mode.</p>	

Entering User Mode

WARNING: *The CX-04 is not in operation as a gas detector while in User Mode.*

1. Take the CX-04 to a non-hazardous location and turn it off if it is on.
2. Press and hold AIR, then press and hold POWER MODE. When you hear a beep, release the buttons.
3. The screen that appears depends on the setting of User Mode's **PASS-W** item.
If **PASS-W** is set to **OFF** (factory setting), continue with Step 6.
If **PASS-W** is set to **ON**, continue with Step 4.

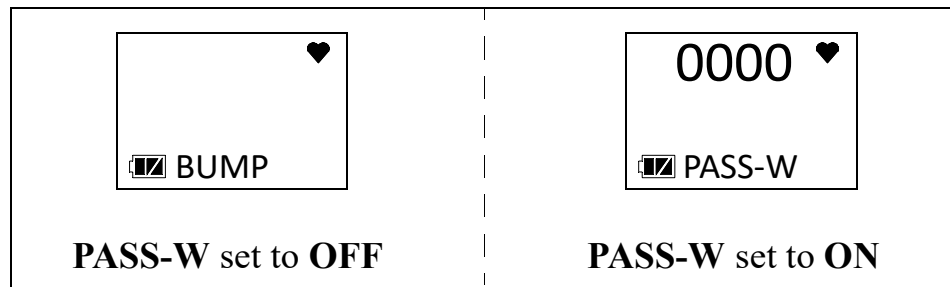

4. If **PASS-W** is set to **ON** in User Mode, a password screen appears and the first digit flashes. The factory-set password is **0405** but it can be changed.
5. Use AIR to select each password number then press POWER MODE to save it and move on to the next number. To go back a number, press and hold AIR and POWER MODE for a few seconds. To reverse the direction of change (ie. from increasing to decreasing or vice versa):
 - a. Press and hold AIR.
 - b. Immediately press POWER MODE and then release both buttons.

6. The **BUMP** item displays.



7. Use AIR to move through the User Mode items.

Tips for Using User Mode

- To scroll from one item to the next, press and release AIR. To reverse the scrolling direction:
 - a. Press and hold AIR.
 - b. Immediately press POWER MODE and then release both buttons.
 - c. The scrolling direction returns to the original direction when you exit and reenter a menu.
- To skip an item when a question is asked, press and release AIR.
- To enter an item and to save any changes, press and release POWER MODE.
- To change a flashing parameter, press and release AIR. To reverse the direction of change (ie. from increasing to decreasing or vice versa):
 - a. Press and hold AIR.
 - b. Immediately press POWER MODE and then release both buttons.
- To exit an entered item without saving a change, press and hold AIR and POWER MODE for a few seconds.

Performing a Bump Test (BUMP)

Bump test the instrument before each day's use with a known concentration of the target gas. The instrument does not need to be calibrated unless it does not pass the bump test.

To bump test the CX-04, you need:

- Calibration gas cylinder (RKI Instruments recommends using 50 ppm CO in N₂)
 - 0.25 LPM fixed flow regulator
 - Non-absorbent tubing
 - Calibration cup
1. Confirm that the CX-04's calibration gas value matches the concentration listed on the calibration gas cylinder as described on page 60.
 2. Confirm that the regulator knob is turned all the way clockwise. Screw the 0.25 LPM fixed flow regulator onto the calibration cylinder.

3. Install the calibration cup onto the CX-04. Be sure the calibration cup is installed in the correct direction and that it is pushed on all the way.

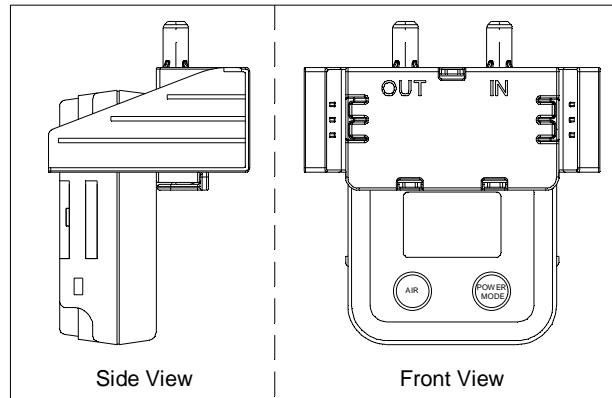

4. Use the tubing to connect the regulator to the inlet of the calibration cup (labeled “IN”).
5. While in User Mode, press AIR to scroll to **BUMP**.



6. Press and release POWER MODE. The display shows the gas assigned to Cylinder A and its assigned calibration value (see page 60 if the calibration value does not match the calibration gas cylinder’s concentration). The bottom of the screen alternates between “CYL A” and “BUMP”.

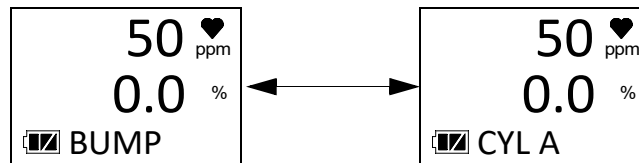

7. If necessary, use AIR to scroll to the Bump screen for the gas you want to bump test. As shipped from the factory, CO and O₂ are both assigned to Cylinder A.
8. Make sure the CX-04 has been turned on for at least 45 seconds before continuing.
9. Turn the regulator knob counterclockwise to open the regulator.
10. Press and release POWER MODE.
11. The gas reading flashes, the bottom of the screen alternates between “APLY” and “BUMP”, and the bottom of the screen counts down from the time set in **BUMP.SET\SETTING\GAS.TIME**.

To back out of the gas application screen without performing the bump test, press and release AIR and POWER MODE together.

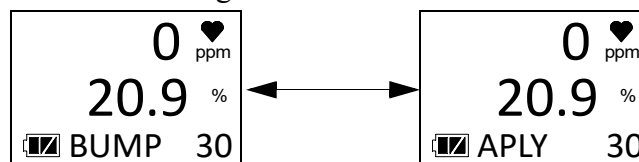

12. At the end of the countdown, the instrument analyzes the results. Follow the flow chart to determine the bump test outcome.

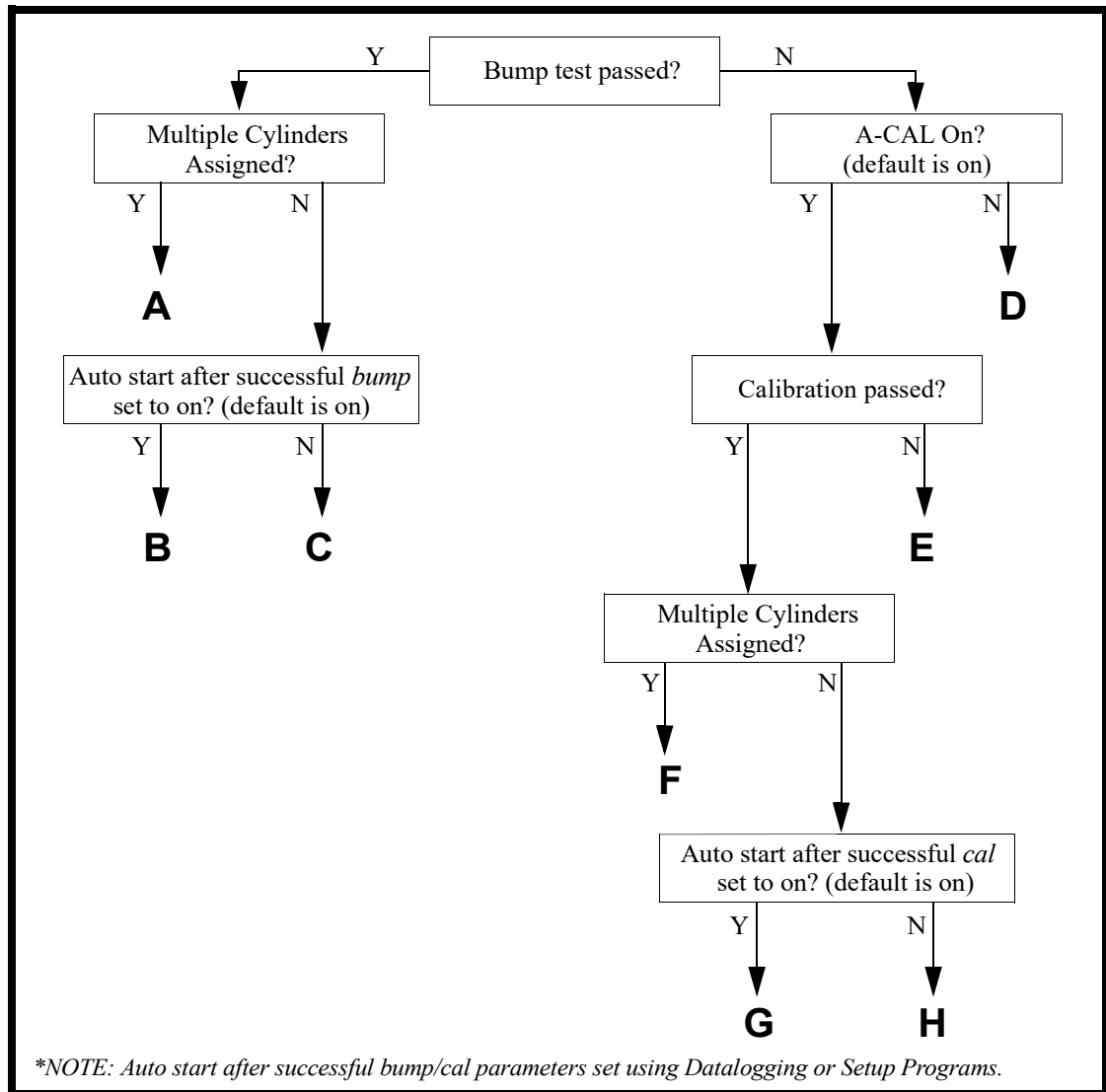
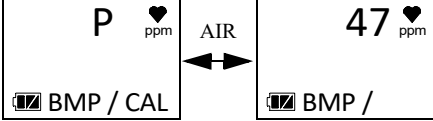
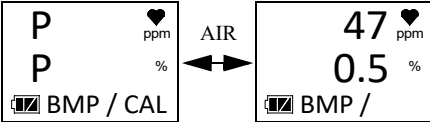
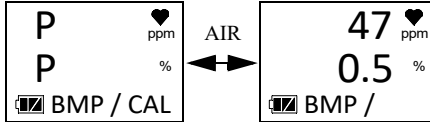

Figure 6: Bump Test Flow Chart

Option A from Flow Chart	Option B from Flow Chart	Option C from Flow Chart
<ul style="list-style-type: none"> • Bump test passed • Multiple cylinders assigned 	<ul style="list-style-type: none"> • Bump test passed • One cylinder assigned • Auto Start After Successful Bump set to ON (factory setting) 	<ul style="list-style-type: none"> • Bump test passed • One cylinder assigned • Auto Start After Successful Bump set to OFF (factory setting is ON)
<p>1. The instrument indicates that the bump test passed. Use AIR to scroll between the bump test result and the bump test gas reading.</p>  <p>2. Close the regulator.</p> <p>3. Press and release POWER MODE to move to the BUMP CYL X screen for the next cylinder.</p> <p>4. Unscrew the regulator from the first cylinder and screw it into the next cylinder.</p> <p>5. Repeat Step 9 through Step 12.</p> <p>6. After the last cylinder is bump tested, press and release POWER MODE to go to the START item in the BUMP menu.</p> <p>7. Remove the calibration cup.</p> <p>8. Press and release POWER MODE to enter Measuring Mode.</p>	<p>1. The instrument indicates that all channels passed the bump test. Use AIR to scroll between the bump test results and the bump test gas readings.</p>  <p>2. Close the regulator.</p> <p>3. Unscrew the regulator.</p> <p>4. Remove the calibration cup.</p> <p>5. Press and release POWER MODE to enter Measuring Mode.</p>	<p>1. The instrument indicates that all channels passed the bump test. Use AIR to scroll between the bump test results and the bump test gas readings.</p>  <p>2. Close the regulator.</p> <p>3. Unscrew the regulator.</p> <p>4. Remove the calibration cup.</p> <p>5. Press and release POWER MODE to return to the START item in the BUMP menu.</p> <p>6. Press and release POWER MODE to enter Measuring Mode.</p>

Option D from Flow Chart	Option E from Flow Chart	Option F from Flow Chart
<ul style="list-style-type: none"> • Bump test failed • A-CAL set to OFF (factory setting is ON) 	<ul style="list-style-type: none"> • Bump test failed • A-CAL set to ON (factory setting) • Calibration failed 	<ul style="list-style-type: none"> • Bump test failed • A-CAL set to ON (factory setting) • Calibration passed • Multiple cylinders assigned
<ol style="list-style-type: none"> The instrument shows which channels passed or failed the bump test. The LEDs flash and the buzzer sounds. Use AIR to scroll between the results and the readings. <div style="display: flex; justify-content: space-around; align-items: center; margin: 10px 0;"> <div style="border: 1px solid black; padding: 5px; text-align: center;"> <p>F ppm</p> <p>P %</p> <p>BMP / CAL</p> </div> <div style="font-size: 2em;">↔</div> <div style="border: 1px solid black; padding: 5px; text-align: center;"> <p>15 ppm</p> <p>0.5 %</p> <p>BMP /</p> </div> </div> Close the regulator. Unscrew the regulator. Remove the calibration cup. Press and release POWER MODE to return to the BUMP CYLA item in the BUMP menu. Use AIR to scroll to START and press and release POWER MODE to enter Measuring Mode. Calibrate the CX-04 as soon as possible. 	<ol style="list-style-type: none"> A calibration immediately and automatically starts for the channel that failed the bump test. Continue to apply the calibration gas. <ol style="list-style-type: none"> The calibration time is the difference between the GAS TIME and the CAL TIME values defined in the BUMP SET\SETTINGS item in User Mode. <div style="display: flex; justify-content: space-around; align-items: center; margin: 10px 0;"> <div style="border: 1px solid black; padding: 5px; text-align: center;"> <p>18.0 ppm</p> <p>APLY 60</p> </div> <div style="font-size: 2em;">↔</div> <div style="border: 1px solid black; padding: 5px; text-align: center;"> <p>18.0 ppm</p> <p>CAL 60</p> </div> </div> The instrument shows which channels passed or failed the bump test/calibration. The LEDs flash and the buzzer sounds. Use AIR to scroll between the results and the readings. <div style="display: flex; justify-content: space-around; align-items: center; margin: 10px 0;"> <div style="border: 1px solid black; padding: 5px; text-align: center;"> <p>P ppm</p> <p>F F %</p> <p>BMP / CAL</p> </div> <div style="font-size: 2em;">↔</div> <div style="border: 1px solid black; padding: 5px; text-align: center;"> <p>51 ppm</p> <p>18.0 %</p> <p>BMP /</p> </div> </div> <div style="display: flex; justify-content: center; align-items: center; margin: 10px 0;"> <div style="font-size: 2em;">↙</div> <div style="border: 1px solid black; padding: 5px; text-align: center; margin: 0 10px;"> <p>17.5 ppm</p> <p>/ CAL</p> </div> <div style="font-size: 2em;">↘</div> </div> Close the regulator. Unscrew the regulator. Remove the calibration cup. Press and release POWER MODE to return to the BUMP CYLA item in the BUMP menu. Use AIR to scroll to START and press and release POWER MODE to enter Measuring Mode. 	<ol style="list-style-type: none"> A calibration immediately and automatically starts for the channel that failed the bump test. Continue to apply the calibration gas. <ol style="list-style-type: none"> The calibration time is the difference between the GAS TIME and the CAL TIME values defined in the BUMP SET\SETTINGS item in User Mode. <div style="display: flex; justify-content: space-around; align-items: center; margin: 10px 0;"> <div style="border: 1px solid black; padding: 5px; text-align: center;"> <p>20 ppm</p> <p>APLY 60</p> </div> <div style="font-size: 2em;">↔</div> <div style="border: 1px solid black; padding: 5px; text-align: center;"> <p>20 ppm</p> <p>CAL 60</p> </div> </div> The instrument shows pass/fail results of the bump test/calibration. Use AIR to scroll between the results and the readings. <div style="display: flex; justify-content: space-around; align-items: center; margin: 10px 0;"> <div style="border: 1px solid black; padding: 5px; text-align: center;"> <p>F P ppm</p> <p>BMP / CAL</p> </div> <div style="font-size: 2em;">↔</div> <div style="border: 1px solid black; padding: 5px; text-align: center;"> <p>20 ppm</p> <p>BMP /</p> </div> </div> <div style="display: flex; justify-content: center; align-items: center; margin: 10px 0;"> <div style="font-size: 2em;">↙</div> <div style="border: 1px solid black; padding: 5px; text-align: center; margin: 0 10px;"> <p>45 ppm</p> <p>/ CAL</p> </div> <div style="font-size: 2em;">↘</div> </div> Close the regulator. Press and release POWER MODE to move to the BUMP CYL X screen for the next cylinder. Unscrew the regulator from the first cylinder and screw it into the next cylinder. Repeat Step 9 through Step 12. After the last cylinder is bump tested, press and release POWER MODE to go to the START item in the BUMP menu. Remove the calibration cup. Press and release POWER MODE to enter Measuring Mode.

Option G from Flow Chart	Option H from Flow Chart
<ul style="list-style-type: none"> • Bump test failed • A-CAL set to ON (factory setting) • Calibration passed • One cylinder assigned • Auto Start After Successful Cal set to ON (factory setting) 	<ul style="list-style-type: none"> • Bump test failed • A-CAL set to ON (factory setting) • Calibration passed • One cylinder assigned • Auto Start After Successful Cal set to OFF (factory setting is ON)
<ol style="list-style-type: none"> 1. A calibration immediately and automatically starts for the channel that failed the bump test. Continue to apply the calibration gas. 2. The calibration time is the difference between the GAS TIME and the CAL TIME values defined in the BUMP SET\SETTINGS item in User Mode. <div data-bbox="370 871 799 991" style="border: 1px solid black; padding: 5px; margin: 10px 0;"> </div> 3. The instrument shows which channels passed or failed the bump test/calibration. Use AIR to scroll between the results and the readings. <div data-bbox="370 1186 799 1474" style="border: 1px solid black; padding: 5px; margin: 10px 0;"> </div> 4. Close the regulator. 5. Unscrew the regulator. 6. Remove the calibration cup. 7. Press and release POWER MODE to enter Measuring Mode. 	<ol style="list-style-type: none"> 1. A calibration immediately and automatically starts for the channel that failed the bump test. Continue to apply the calibration gas. 2. The calibration time is the difference between the GAS TIME and the CAL TIME values defined in the BUMP SET\SETTINGS item in User Mode. <div data-bbox="868 871 1297 991" style="border: 1px solid black; padding: 5px; margin: 10px 0;"> </div> 3. The instrument shows which channels passed or failed the bump test/calibration. Use AIR to scroll between the results and the readings. <div data-bbox="868 1186 1297 1474" style="border: 1px solid black; padding: 5px; margin: 10px 0;"> </div> 4. Close the regulator. 5. Unscrew the regulator. 6. Remove the calibration cup. 7. Press and release POWER MODE to return to the START item in the BUMP menu. 8. Press and release POWER MODE to enter Measuring Mode.

Performing a Calibration (GAS CAL)

- Bump test the instrument before each day's use with a known concentration of the target gas. A bump test can be done in User Mode's **BUMP** item or by applying gas in Measuring Mode. The instrument does not need to be calibrated unless it does not pass the User Mode bump test or does not respond appropriately, as defined by the user, in Measuring Mode.
- To fully calibrate the sensors, you must do a fresh air adjustment (**AIR CAL**) and a span adjustment (**A-CAL** or **E-CAL**).
- The CX-04 can be calibrated using either **A-CAL** or **E-CAL** depending on the setting of the **E-CAL** User Mode item.
 - **A-CAL** (appears if **E-CAL** User Mode item is set to **OFF**): Apply gas for a period of time, then press and release **POWER MODE** to perform the adjustment.
 - **E-CAL** (appears if **E-CAL** User Mode item is set to something besides **OFF**): As soon as gas is applied and the reading reaches 10% of the auto calibration value, the instrument counts down from the number of seconds specified in the **E-CAL** User Mode item and automatically performs the adjustment.

Performing a Fresh Air Adjustment (AIR)

1. Find a fresh air environment, an environment of normal oxygen content (20.9%) that is free of toxic and combustible gases.
2. While in User Mode, press **AIR** to scroll to **GAS CAL**.



3. Press and release **POWER MODE**. The **AIR** item appears.



4. Press and release **POWER MODE** to enter the **AIR** menu.

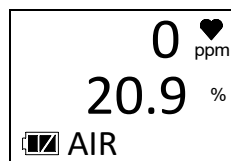

5. To return to the **AIR** menu without performing a fresh air adjustment, press and release **POWER MODE**.

- To perform a fresh air adjustment, press and hold AIR until the screen prompts you to release it.

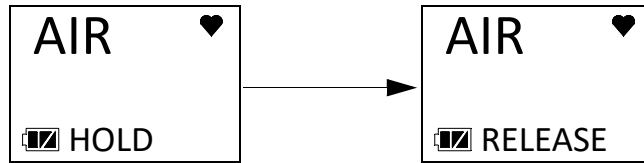

- If the fresh air adjustment passes, the instrument returns to the **AIR** item in the **GAS CAL** menu.
- If the fresh air adjustment fails, “FAIL AIR” displays. Press and release **POWER MODE** to acknowledge the failure. See page 79.

Performing a Span Adjustment in A-CAL

The **A-CAL** item only appears if **E-CAL** in User Mode is set to **OFF** (factory setting). If **E-CAL** is set to **ON**, see page 55 for calibration instructions.

Preparing for Span Adjustment

To adjust the span on the CX-04, you need:

- Calibration gas cylinder (RKI Instruments recommends using 50 ppm CO in N₂)
 - 0.25 LPM fixed flow regulator
 - Non-absorbent tubing
 - Calibration cup
1. Confirm that the CX-04’s calibration gas value matches the concentration listed on the calibration gas cylinder as described on page 60.
 2. Confirm that the regulator knob is turned all the way clockwise. Screw the 0.25 LPM fixed flow regulator onto the calibration cylinder.
 3. Install the calibration cup onto the CX-04. Be sure the calibration cup is installed in the correct direction and that it is pushed on all the way.

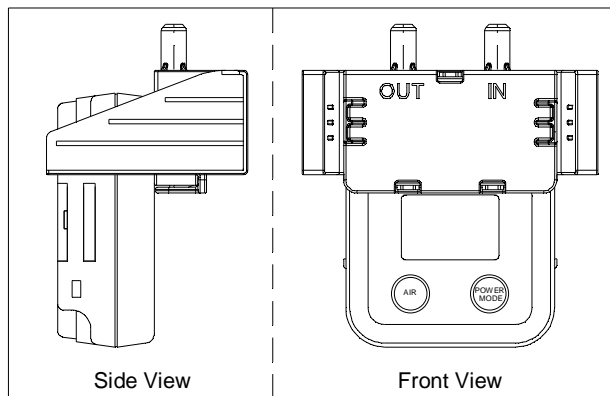

4. Use the tubing to connect the regulator to the inlet of the calibration cup (labeled “IN”).

Performing a Span Adjustment

1. While in User Mode, press AIR to scroll to **GAS CAL**.



2. Press and release POWER MODE. The **AIR** item appears.
3. Use AIR to scroll to the **A-CAL** item.

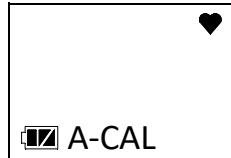

4. Press and release POWER MODE. The display shows the gas assigned to Cylinder A and its assigned calibration value (see page 60 if the calibration value does not match the calibration gas cylinder's concentration). The bottom of the screen alternates between "CYL A" and "A-CAL".

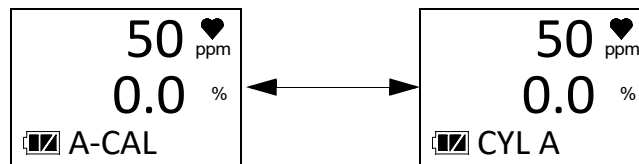

5. If necessary, use AIR to scroll to the Auto Cal screen for the gas you want to calibrate. As shipped from the factory, CO and O₂ are assigned to Cylinder A.
6. Make sure the CX-04 has been turned on for at least 45 seconds before continuing.
7. Press and release POWER MODE.
8. The gas reading flashes and the bottom of the screen alternates between "APPLY" and "A-CAL".

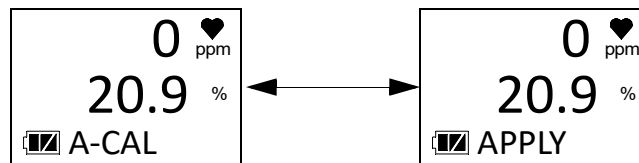

NOTE: To back out of the gas application screen without performing the calibration, press and release AIR and POWER MODE together.

9. Turn the regulator knob counterclockwise to open the regulator.
10. Allow the gas to flow for 1 minute.
11. Press and release POWER MODE.

12. Follow the flow chart to determine the calibration outcome.

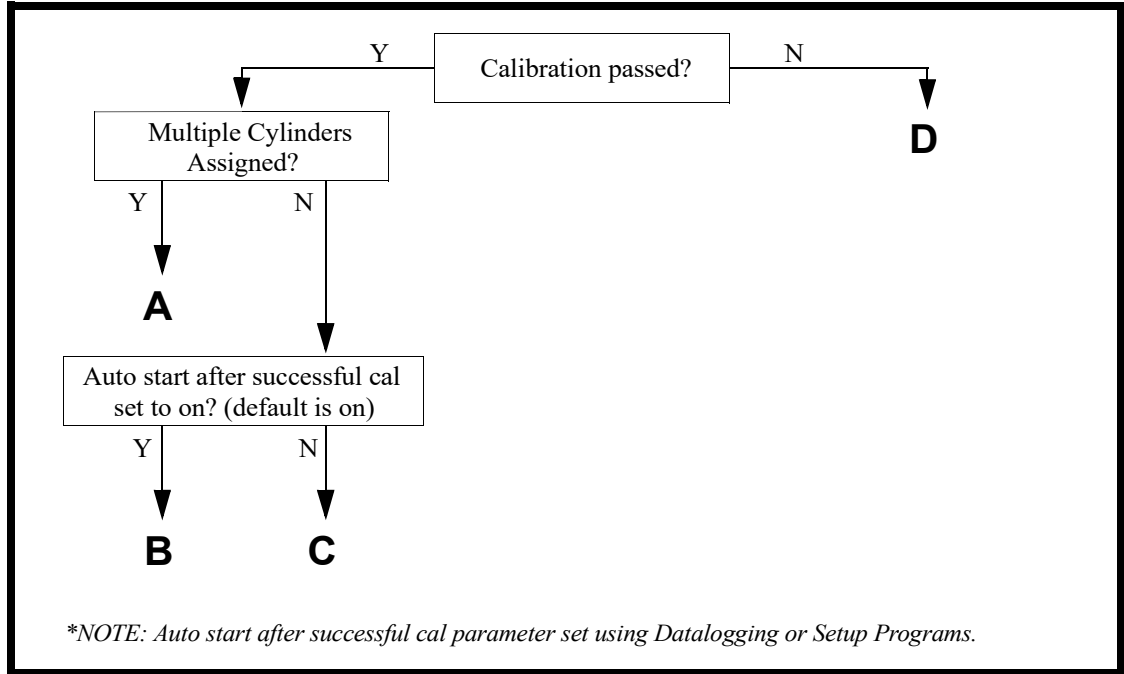

Figure 7: Calibration Flow Chart

Option A from Flow Chart	Option B from Flow Chart
<ul style="list-style-type: none"> • Calibration passed • Multiple cylinders assigned 	<ul style="list-style-type: none"> • Calibration passed • One cylinder assigned • Auto Start After Successful Cal set to ON (factory setting)
<ol style="list-style-type: none"> The instrument indicates that the calibration passed. <div data-bbox="402 464 597 596" style="border: 1px solid black; padding: 5px; margin: 10px 0;"> <p style="text-align: center;">PASS ♥</p> <p style="text-align: center;">A-CAL</p> </div> The instrument shows the current gas reading. <div data-bbox="402 684 597 816" style="border: 1px solid black; padding: 5px; margin: 10px 0;"> <p style="text-align: center;">51 ♥ ppm</p> <p style="text-align: center;">%</p> <p style="text-align: center;">A-CAL</p> </div> If MAX.SPAN is set to ON (default is OFF, see page 105), the response reading's maximum adjustment is displayed. A maximum span of 100 ppm on the CO channel indicates that the reading could have been adjusted up to 100 ppm. If the maximum span value is close to the calibration gas value, the sensor should be replaced soon. The maximum CO adjustment is either twice the calibration value or full scale, whichever is lower. The maximum oxygen adjustment is 25.0% volume. <div data-bbox="402 1285 597 1417" style="border: 1px solid black; padding: 5px; margin: 10px 0;"> <p style="text-align: center;">91 ♥ ppm</p> <p style="text-align: center;">%</p> <p style="text-align: center;">MAX.SPAN</p> </div> Close the regulator. The instrument continues to the A-CAL CYL X screen. Unscrew the regulator from the first cylinder and screw it into the next cylinder. Press and release POWER MODE to start the next cylinder's calibration. Repeat Step 9 through Step 12. After the last cylinder is calibrated, the instrument continues to the START item in the A-CAL menu. Remove the calibration cup. Press and release POWER MODE to enter Measuring Mode. 	<ol style="list-style-type: none"> The instrument indicates that all channels passed the calibration. <div data-bbox="898 464 1092 596" style="border: 1px solid black; padding: 5px; margin: 10px 0;"> <p style="text-align: center;">PASS ♥ ppm</p> <p style="text-align: center;">PASS %</p> <p style="text-align: center;">A-CAL</p> </div> The instrument shows the current gas readings. <div data-bbox="898 684 1092 816" style="border: 1px solid black; padding: 5px; margin: 10px 0;"> <p style="text-align: center;">51 ♥ ppm</p> <p style="text-align: center;">0.5 %</p> <p style="text-align: center;">A-CAL</p> </div> If MAX.SPAN is set to ON (default is OFF, see page 105), the response reading's maximum adjustment is displayed. A maximum span of 100 ppm on the CO channel indicates that the reading could have been adjusted up to 100 ppm. If the maximum span value is close to the calibration gas value, the sensor should be replaced soon. The maximum CO adjustment is either twice the calibration value or full scale, whichever is lower. The maximum oxygen adjustment is 25.0% volume. <div data-bbox="898 1285 1092 1417" style="border: 1px solid black; padding: 5px; margin: 10px 0;"> <p style="text-align: center;">91 ♥ ppm</p> <p style="text-align: center;">24.0 %</p> <p style="text-align: center;">MAX.SPAN</p> </div> Close the regulator. Unscrew the regulator. Remove the calibration cup. The instrument automatically begins its warmup sequence and enters Measuring Mode.

Option C from Flow Chart	Option D from Flow Chart
<ul style="list-style-type: none"> • Calibration passed • One cylinder assigned • Auto Start After Successful Cal set to OFF (factory setting is ON) 	<ul style="list-style-type: none"> • Calibration failed
<ol style="list-style-type: none"> 1. The instrument indicates that all channels passed the calibration. <div data-bbox="402 531 597 663" style="border: 1px solid black; padding: 5px; margin: 10px 0;"> <p style="text-align: center;">PASS ♥ PASS ppm % A-CAL</p> </div> 2. The instrument shows the current gas readings. <div data-bbox="402 758 597 890" style="border: 1px solid black; padding: 5px; margin: 10px 0;"> <p style="text-align: center;">51 ♥ ppm 0.5 % A-CAL</p> </div> 3. If MAX.SPAN is set to ON (default is OFF, see page 105), the response reading's maximum adjustment is displayed. A maximum span of 100 ppm on the CO channel indicates that the reading could have been adjusted up to 100 ppm. If the maximum span value is close to the calibration gas value, the sensor should be replaced soon. <p style="margin-top: 20px;">The maximum CO adjustment is either twice the calibration value or full scale, whichever is lower. The maximum oxygen adjustment is 25.0% volume.</p> <div data-bbox="402 1472 597 1604" style="border: 1px solid black; padding: 5px; margin: 10px 0;"> <p style="text-align: center;">91 ♥ ppm 24.0 % MAX.SPAN</p> </div> 4. Close the regulator. 5. Unscrew the regulator. 6. Remove the calibration cup. 7. The instrument continues to the START item in the A-CAL menu. 8. Press and release POWER MODE to enter Measuring Mode. 	<ol style="list-style-type: none"> 1. The instrument indicates which channels failed the calibration. <div data-bbox="898 531 1092 663" style="border: 1px solid black; padding: 5px; margin: 10px 0;"> <p style="text-align: center;">FAIL ♥ FAIL ppm % A-CAL</p> </div> 2. Close the regulator. 3. Unscrew the regulator. 4. Remove the calibration cup. 5. Press and release POWER MODE to return to the A-CAL CYL X screen in the A-CAL menu. 6. See “Troubleshooting” on page 79.

Performing a Span Adjustment in E-CAL

The E-CAL item only appears if E-CAL in User Mode is set to **ON** (factory setting is **OFF**). If E-CAL is set to **OFF**, see page 50 for calibration instructions.

Preparing for Span Adjustment

To adjust the span on the CX-04, you need:

- Calibration gas cylinder (RKI Instruments recommends using 50 ppm CO in N₂)
 - 0.25 LPM fixed flow regulator
 - Non-absorbent tubing
 - Calibration cup
1. Confirm that the CX-04's calibration gas value matches the concentration listed on the calibration gas cylinder as described on page 60.
 2. Confirm that the regulator knob is turned all the way clockwise. Screw the 0.25 LPM fixed flow regulator onto the calibration cylinder.
 3. Install the calibration cup onto the CX-04. Be sure the calibration cup is installed in the correct direction and that it is pushed on all the way.

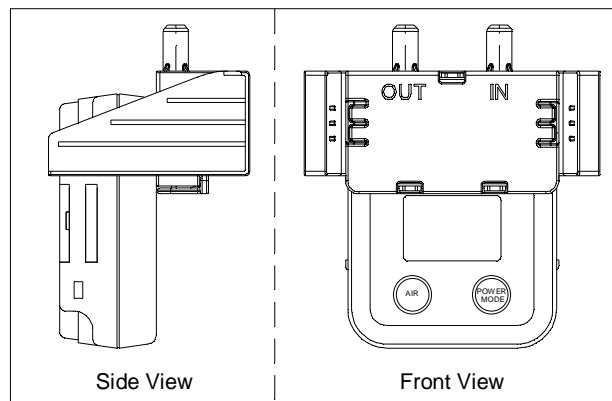

4. Use the tubing to connect the regulator to the inlet of the calibration cup (labeled “IN”).

Performing a Calibration

1. While in User Mode, press AIR to scroll to **GAS CAL**.



2. Press and release POWER MODE. The **AIR** item appears.
3. Use AIR to scroll to the **E-CAL** item.



- Press and release POWER MODE. The display shows the gas assigned to Cylinder A and its assigned calibration value (see page 60 if the calibration value does not match the calibration gas cylinder's concentration). The bottom of the screen alternates between "CYL A" and "E-CAL".

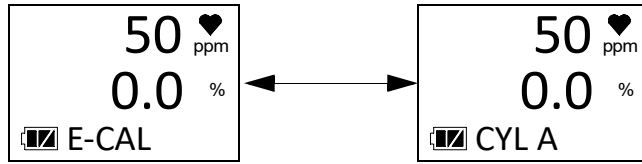

- If necessary, use AIR to scroll to the Easy Cal screen for the gas you want to calibrate. As shipped from the factory, CO and O₂ are assigned to Cylinder A.
- Make sure the CX-04 has been turned on for at least 45 seconds before continuing.
- Press and release POWER MODE.
- The gas reading flashes and the bottom of the screen says "GAS IN".

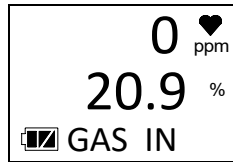

- Turn the regulator knob counterclockwise to open the regulator.
- Once the gas reading reaches 10% of the auto calibration value, the screen starts counting down from the time specified in the E-CAL User Mode item. In the example below, E-CAL is set to 60 seconds.

To back out of the gas application screen without performing the calibration, press and release AIR and POWER MODE together.

If the reading never reaches 10% of the auto calibration value, press and release POWER MODE to fail the calibration.

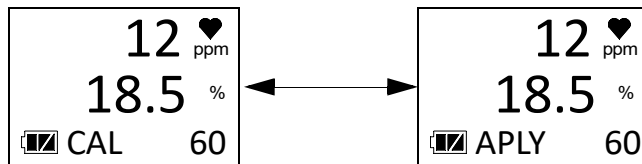

- At the end of the countdown, the instrument makes the span adjustment.

12. Follow the flow chart to determine the calibration outcome.

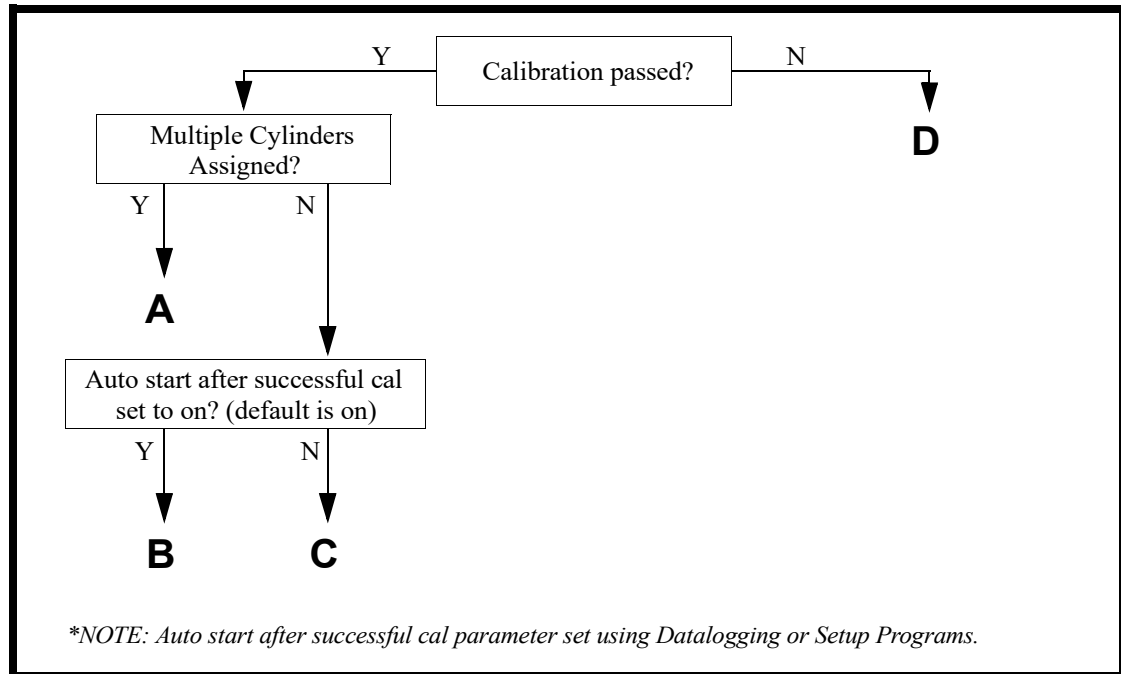

Figure 8: Calibration Flow Chart

Option A from Flow Chart	Option B from Flow Chart
<ul style="list-style-type: none"> • Calibration passed • Multiple cylinders assigned 	<ul style="list-style-type: none"> • Calibration passed • One cylinder assigned • Auto Start After Successful Cal set to ON (factory setting)
<ol style="list-style-type: none"> The instrument indicates that the calibration passed. <div data-bbox="402 470 597 604" style="border: 1px solid black; padding: 5px; margin: 10px 0;"> <p style="text-align: center; font-size: 24pt;">PASS ♥</p> <p style="text-align: center;">E-CAL</p> </div> The instrument shows the current gas reading. <div data-bbox="402 688 597 823" style="border: 1px solid black; padding: 5px; margin: 10px 0;"> <p style="text-align: center; font-size: 24pt;">51 ♥ ppm</p> <p style="text-align: center;">%</p> <p style="text-align: center;">E-CAL</p> </div> If MAX.SPAN is set to ON (default is OFF, see page 105), the response reading's maximum adjustment is displayed. A maximum span of 100 ppm on the CO channel indicates that the reading could have been adjusted up to 100 ppm. If the maximum span value is close to the calibration gas value, the sensor should be replaced soon. The maximum CO adjustment is either twice the calibration value or full scale, whichever is lower. The maximum oxygen adjustment is 25.0% volume. <div data-bbox="402 1289 597 1423" style="border: 1px solid black; padding: 5px; margin: 10px 0;"> <p style="text-align: center; font-size: 24pt;">91 ♥ ppm</p> <p style="text-align: center;">%</p> <p style="text-align: center;">MAX.SPAN</p> </div> Close the regulator. The instrument continues to the E-CAL CYL X screen. Unscrew the regulator from the first cylinder and screw it into the next cylinder. Press and release POWER MODE to start the next cylinder's calibration. Repeat Step 9 through Step 12. After the last cylinder is calibrated, the instrument continues to the START item in the E-CAL menu. Remove the calibration cup. Press and release POWER MODE to enter Measuring Mode. 	<ol style="list-style-type: none"> The instrument indicates that all channels passed the calibration. <div data-bbox="899 470 1094 604" style="border: 1px solid black; padding: 5px; margin: 10px 0;"> <p style="text-align: center; font-size: 24pt;">PASS ♥ PASS %</p> <p style="text-align: center;">E-CAL</p> </div> The instrument shows the current gas readings. <div data-bbox="899 688 1094 823" style="border: 1px solid black; padding: 5px; margin: 10px 0;"> <p style="text-align: center; font-size: 24pt;">51 ♥ ppm</p> <p style="text-align: center; font-size: 24pt;">0.5 %</p> <p style="text-align: center;">E-CAL</p> </div> If MAX.SPAN is set to ON (default is OFF, see page 105), the response reading's maximum adjustment is displayed. A maximum span of 100 ppm on the CO channel indicates that the reading could have been adjusted up to 100 ppm. If the maximum span value is close to the calibration gas value, the sensor should be replaced soon. The maximum CO adjustment is either twice the calibration value or full scale, whichever is lower. The maximum oxygen adjustment is 25.0% volume. <div data-bbox="899 1289 1094 1423" style="border: 1px solid black; padding: 5px; margin: 10px 0;"> <p style="text-align: center; font-size: 24pt;">91 ♥ ppm</p> <p style="text-align: center; font-size: 24pt;">24.0 %</p> <p style="text-align: center;">MAX.SPAN</p> </div> Close the regulator. Unscrew the regulator. Remove the calibration cup. The instrument automatically begins its warmup sequence and enters Measuring Mode.

Option C from Flow Chart	Option D from Flow Chart
<ul style="list-style-type: none"> • Calibration passed • One cylinder assigned • Auto Start After Successful Cal set to OFF (factory setting is ON) 	<ul style="list-style-type: none"> • Calibration failed
<ol style="list-style-type: none"> 1. The instrument indicates that all channels passed the calibration. <div data-bbox="402 531 597 663" style="border: 1px solid black; padding: 5px; margin: 10px 0;"> <p style="text-align: center;">PASS ♥ ppm PASS % E-CAL</p> </div> 2. The instrument shows the current gas readings. <div data-bbox="402 758 597 890" style="border: 1px solid black; padding: 5px; margin: 10px 0;"> <p style="text-align: center;">51 ♥ ppm 0.5 % E-CAL</p> </div> 3. If MAX.SPAN is set to ON (default is OFF, see page 105), the response reading's maximum adjustment is displayed. A maximum span of 100 ppm on the CO channel indicates that the reading could have been adjusted up to 100 ppm. If the maximum span value is close to the calibration gas value, the sensor should be replaced soon. The maximum CO adjustment is either twice the calibration value or full scale, whichever is lower. The maximum oxygen adjustment is 25.0% volume. <div data-bbox="402 1436 597 1568" style="border: 1px solid black; padding: 5px; margin: 10px 0;"> <p style="text-align: center;">91 ♥ ppm 24.0 % MAX.SPAN</p> </div> 4. Close the regulator. 5. Unscrew the regulator. 6. Remove the calibration cup. 7. The instrument continues to the START item in the E-CAL menu. 8. Press and release POWER MODE to enter Measuring Mode. 	<ol style="list-style-type: none"> 1. The instrument indicates which channels failed the calibration. <div data-bbox="898 531 1092 663" style="border: 1px solid black; padding: 5px; margin: 10px 0;"> <p style="text-align: center;">FAIL ♥ ppm FAIL % E-CAL</p> </div> 2. Close the regulator. 3. Unscrew the regulator. 4. Remove the calibration cup. 5. Press and release POWER MODE to return to the E-CAL CYL X screen in the E-CAL menu. 6. See "Troubleshooting" on page 79.

Setting the Calibration Values in CAL--P

1. While in User Mode, press AIR to scroll to GAS CAL.



2. Press and release POWER MODE. The AIR item appears.
3. Use AIR to scroll to the A-CAL item (E-CAL if E-CAL in User Mode is set to ON).

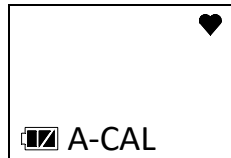

4. Press and release POWER MODE. The Auto Cal screen for the gas assigned to Cylinder A displays.

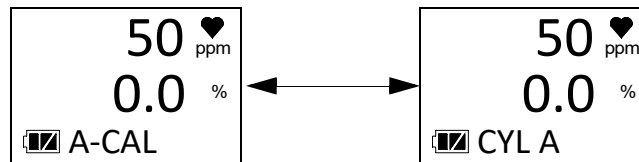

5. Use AIR to scroll to CAL--P.



6. Press and release POWER MODE. The CO channel displays.



7. Use AIR to scroll to the gas whose calibration gas value you want to change.

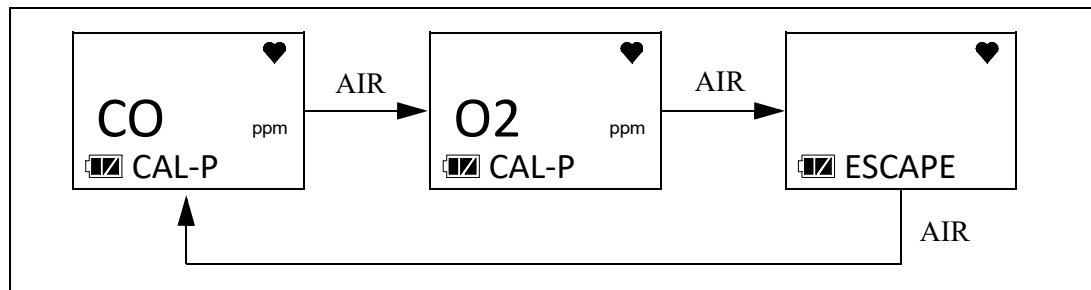

- Press and release POWER MODE. The calibration value begins to flash.

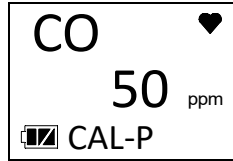

- Use AIR to adjust the calibration gas value. The calibration gas value in the instrument must match the value listed on the calibration gas cylinder you are using. Limits on the calibration gas value are shown in the table below.

Table 9: Calibration Concentration Limits

Channel	Min. Cal. Concentration	Max. Cal Concentration
Carbon Monoxide	15 ppm	2,000 ppm
Oxygen	0% volume	18.0% volume

- Press and release POWER MODE to save the change. The calibration gas value stops flashing and the unit returns to the gas name screen.
- Repeat steps Step 7 - Step 10 for the other channel, if necessary.
- Use AIR to scroll to **ESCAPE**.
- Press and release POWER MODE to return to the **CAL--P** item in the **A-CAL** menu.
- Press AIR to scroll to **ESCAPE**.
- Press and release POWER MODE to return to the **A-CAL** item in the **GAS CAL** menu.
- See “Exiting the GAS CAL Menu” on page 63 to return to User Mode.

Making Cylinder Selections in CYL SEL

The **CYL SEL** menu item allows you to assign cylinders for calibration. As shipped from the factory, CO and O₂ are assigned to Cylinder A. There are 5 cylinder assignments available: A, B, C, D, and E.

- While in User Mode, press AIR to scroll to **GAS CAL**.



- Press and release POWER MODE. The **AIR CAL** menu item appears.

- Use AIR to scroll to the **A-CAL** item (**E-CAL** if **E-CAL** in User Mode is set to **ON**).



- Press and release POWER MODE. The Auto Cal screen for the gas assigned to Cylinder A displays.

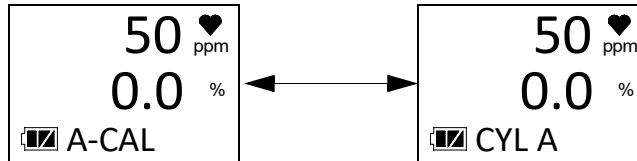

- Use AIR to scroll to **CYL SEL**.



- Press and release POWER MODE. The CO channel displays.



- Use AIR to scroll to the gas whose cylinder assignment you want to change.

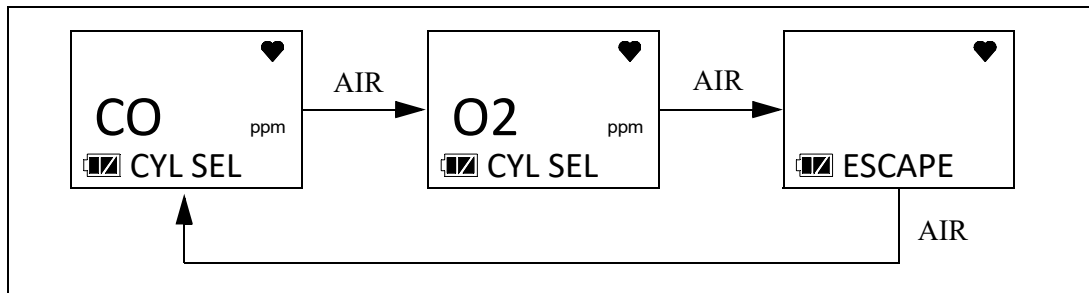

- Press and release POWER MODE. The current setting flashes. In the example below, CO is selected.



- Use AIR to change the cylinder assignment. The choices are A, B, C, D, and E.
- Press and release POWER MODE to save the change. The cylinder assignment stops flashing and the unit returns to the gas selection screen.

11. Repeat steps Step 7 - Step 10 for the other channel, if necessary.
12. Use AIR to scroll to **ESCAPE**.
13. Press and release POWER MODE. The instrument returns to the **CYL SEL** menu item in the Auto Cal Menu.
14. Press AIR to scroll to **ESCAPE**.
15. Press and release POWER MODE. The instrument returns to the **A-CAL** menu item in the **GAS CAL** menu.
16. See “Exiting the GAS CAL Menu” on page 63 to return to User Mode.

Exiting the GAS CAL Menu

1. While in the **GAS CAL** menu, press AIR to scroll to **ESCAPE**.
2. Press and release POWER MODE to return to the **GAS CAL** item in User Mode.
3. See “Entering Measuring Mode (START)” on page 77 to enter Measuring Mode.

Setting Calibration Parameters (CAL SET)

The **CAL SET** menu has 4 items: **CAL.RMDR**, **CAL.INT**, **CAL.EXPD**, and **ESCAPE**.

1. While in User Mode, press AIR to scroll to **CAL SET**.



2. Press and release POWER MODE. The **CAL.RMDR** item appears.



CAL.RMDR

ON (factory setting): The CX-04 gives an indication at start up if it is due for calibration. The type of indication depends on the **CAL.EXPD** setting (see page 64).

OFF: The CX-04 does not give an indication at start up if it is due for calibration.

1. After entering the **CAL SET** menu, press AIR to scroll to **CAL.RMDR**.



2. Press and release POWER MODE. The current setting flashes.
3. Use AIR to display the desired setting.
4. Press and release POWER MODE to save the setting and return to the **CAL.RMDR** item in the **CAL SET** menu.
5. See “Exiting the CAL SET Menu” on page 65 to return to User Mode.

CAL.INT

This setting defines the amount of time between calibrations and can be set in 1 day increments. The minimum setting is **1** day and the maximum setting is **1000** days. The factory setting is **90** days.

1. After entering the **CAL SET** menu, press AIR to scroll to **CAL.INT**.



2. Press and release POWER MODE. The current setting flashes.
3. Use AIR to display the desired setting.
4. Press and release POWER MODE to save the setting and return to the **CAL.INT** item in the **CAL SET** menu.
5. See “Exiting the CAL SET Menu” on page 65 to return to User Mode.

CAL.EXPD

This item defines what indication is given during start up when calibration is due and **CAL.RMDR** is set to **ON** (factory setting).

CONFIRM (factory setting): The CX-04 gives an indication at start up if calibration is past due. Press and release AIR to continue without calibrating or press and release POWER MODE to enter User Mode and perform a calibration.

CANT.USE: The CX-04 gives an indication at start up that calibration is past due. Press and release POWER MODE to enter User Mode and perform a calibration. Pressing AIR has no effect. A successful calibration must be performed in order to use the instrument.

NONE: The CX-04 gives an indication at startup that calibration is past due. It is not necessary to acknowledge the indication. If desired, press POWER MODE to enter User Mode and perform a calibration. The warm-up sequence continues on its own.

1. After entering the **CAL SET** menu, press AIR to scroll to **CAL.EXPD**.



2. Press and release POWER MODE. The current setting flashes.
3. Use AIR to display the desired setting.
4. Press and release POWER MODE to save the setting and return to the **CAL.EXPD** item in the **CAL SET** menu.
5. See “Exiting the CAL SET Menu” on page 65 to return to User Mode.

Exiting the CAL SET Menu

1. While in the **CAL SET** menu, press AIR to scroll to **ESCAPE**.
2. Press and release POWER MODE to return to the **CAL SET** item in User Mode.
3. See “Entering Measuring Mode (START)” on page 77 to enter Measuring Mode.

Setting Bump Test Parameters (BUMP.SET)

The **BUMP.SET** menu has 5 items: **SETTING**, **BP.RMDR**, **BP.INT**, **BP.EXPD**, and **ESCAPE**.

1. While in User Mode, press AIR to scroll to **BUMP.SET**.



2. Press and release POWER MODE. The **SETTING** item appears.



SETTING

The **SETTING** menu has 5 items: **GAS.TIME**, **CHECK**, **CAL.TIME**, **A-CAL**, and **ESCAPE**.

1. After entering the **BUMP.SET** menu, press AIR to scroll to **SETTING**.



2. Press and release POWER MODE. The **GAS.TIME** item appears.

GAS.TIME

The **GAS.TIME** is the amount of time that the instrument is exposed to gas during a bump test. The available choices are **30** seconds (factory setting), **45** seconds, **60** seconds, and **90** seconds.

1. After entering the **SETTING** menu, press AIR to scroll to **GAS.TIME**.



2. Press and release POWER MODE. The current setting flashes.
3. Use AIR to display the desired setting.
4. Press and release POWER MODE to save the setting and return to the **GAS TIME** item in the **SETTING** menu.
5. See “Exiting the SETTING Menu” on page 67 to return to **BUMP.SET** menu.

CHECK

CHECK is the bump test tolerance value and is represented as a percentage of the calibration gas concentration. It is the percentage that the bump test reading can differ from the auto calibration value and still be considered a passed bump test. If the bump test reading differs more, the bump test fails. The available values are **10%**, **20%**, **30%**, **40%**, and **50%** (factory setting).

1. After entering the **SETTING** menu, press AIR to scroll to **CHECK**.



2. Press and release POWER MODE. The current setting flashes.
3. Use AIR to display the desired setting.
4. Press and release POWER MODE to save the setting and return to the **CHECK** item in the **SETTING** menu.
5. See “Exiting the SETTING Menu” on page 67 to return to **BUMP.SET** menu.

CAL.TIME

The **CAL.TIME** is the total time the instrument is exposed to calibration gas if **A-CAL** is set to **ON** and a bump test fails. The bump test time is deducted from the calibration time. For example, if the **CAL.TIME** is set to 90 seconds and the **GAS.TIME** is set to 30 seconds, if the bump test fails, the CX-04 is only exposed to gas for an additional 60 seconds. The available values are **90** seconds (factory setting), and **120** seconds.

1. After entering the **SETTING** menu, press AIR to scroll to **CAL.TIME**.



2. Press and release POWER MODE. The current setting flashes.
3. Use AIR to display the desired setting.
4. Press and release POWER MODE to save the setting and return to the **CAL.TIME** item in the **SETTING** menu.
5. See “Exiting the SETTING Menu” on page 67 to return to **BUMP.SET** menu.

A-CAL

ON (factory setting): If a bump test fails, the unit automatically begins a calibration.

OFF: If a bump test fails, the unit does not automatically begin a calibration.

1. After entering the **SETTING** menu, press AIR to scroll to **A-CAL**.

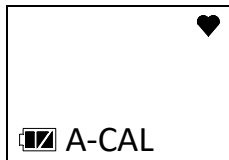

2. Press and release POWER MODE. The current setting flashes.
3. Use AIR to display the desired setting.
4. Press and release POWER MODE to save the setting and return to the **A-CAL** item in the **SETTING** menu.
5. See “Exiting the SETTING Menu” on page 67 to return to **BUMP.SET** menu.

Exiting the SETTING Menu

1. While in the **SETTING** menu, press AIR to scroll to **ESCAPE**.
2. Press and release POWER MODE to return to the **SETTING** item in the **BUMP.SET** menu.
3. See “Exiting the BUMP.SET Menu” on page 69 to return to User Mode.

BP.RMDR

ON: The CX-04 gives an indication at start up if it is due for bump testing. The type of indication depends on the **BP.EXPD** setting (see page 68). If the instrument is not due for bump testing, a check mark appears in the lower left corner of the LCD.

OFF (factory setting): The CX-04 does not give an indication at start up if it is due for bump testing.

1. After entering the **BUMP.SET** menu, press AIR to scroll to **BP.RMDR**.



2. Press and release POWER MODE. The current setting flashes.
3. Use AIR to display the desired setting.
4. Press and release POWER MODE to save the setting and return to the **BP.RMDR** item in the **BUMP.SET** menu.
5. See “Exiting the BUMP.SET Menu” on page 69 to return to User Mode.

BP.INT

This setting defines the amount of time between bump tests and can be set in 1 day increments. The minimum setting is **0** days and the maximum setting is **30** days (factory setting).

1. After entering the **BUMP.SET** menu, press AIR to scroll to **BP.INT**.



2. Press and release POWER MODE. The current setting flashes.
3. Use AIR to display the desired setting.
4. Press and release POWER MODE to save the setting and return to the **BP.INT** item in the **BUMP.SET** menu.
5. See “Exiting the BUMP.SET Menu” on page 69 to return to User Mode.

BP.EXPD

This item defines what indication is given during start up when a bump test is due and **BP.RMDR** is set to **ON** (factory setting is **OFF**).

CONFIRM (factory setting): The CX-04 gives an indication at start up if a bump test is past due. Press and release AIR to continue without bump testing or press and release POWER MODE to enter User Mode and perform a bump test.

CANT.USE: The CX-04 gives an indication at start up that a bump test is past due. Press and release POWER MODE to enter User Mode and perform a bump test. Pressing AIR has no effect. A successful bump test must be performed in order to use the instrument.

NONE: The CX-04 gives an indication at startup that a bump test is past due. It is not necessary to acknowledge the indication. If desired, press POWER MODE to enter User Mode and perform a bump test. The warm-up sequence continues on its own.

1. After entering the **BUMP.SET** menu, press AIR to scroll to **BP.EXPD**.



2. Press and release POWER MODE. The current setting flashes.
3. Use AIR to display the desired setting.
4. Press and release POWER MODE to save the setting and return to the **BP.EXPD** item in the **BUMP.SET** menu.
5. See “Exiting the BUMP.SET Menu” on page 69 to return to User Mode.

Exiting the BUMP.SET Menu

1. While in the **BUMP.SET** menu, press AIR to scroll to **ESCAPE**.
2. Press and release POWER MODE to return to the **BUMP.SET** item in User Mode.
3. See “Entering Measuring Mode (START)” on page 77 to enter Measuring Mode.

Alarm Settings (ALARM--P)

The **ALARM--P** menu has 3 items: **ALARM--P**, **DEF.ALMP**, and **ESCAPE**.

1. While in User Mode, press AIR to scroll to **ALARM--P**.



2. Press and release POWER MODE. The first screen displays.



Setting the Alarm Points

1. After entering the **ALARM-P** menu, press AIR to scroll to the gas name.

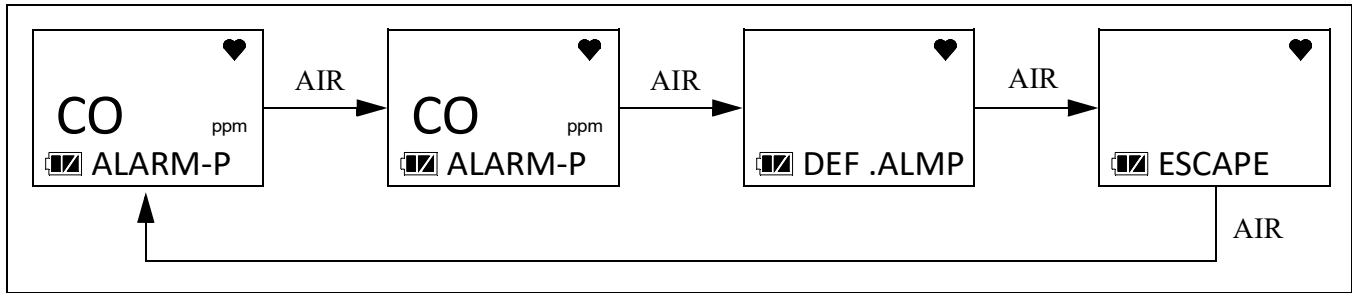

2. Press and release **POWER MODE**.
3. The Warning setpoint flashes. In the example below, the CO channel is selected.

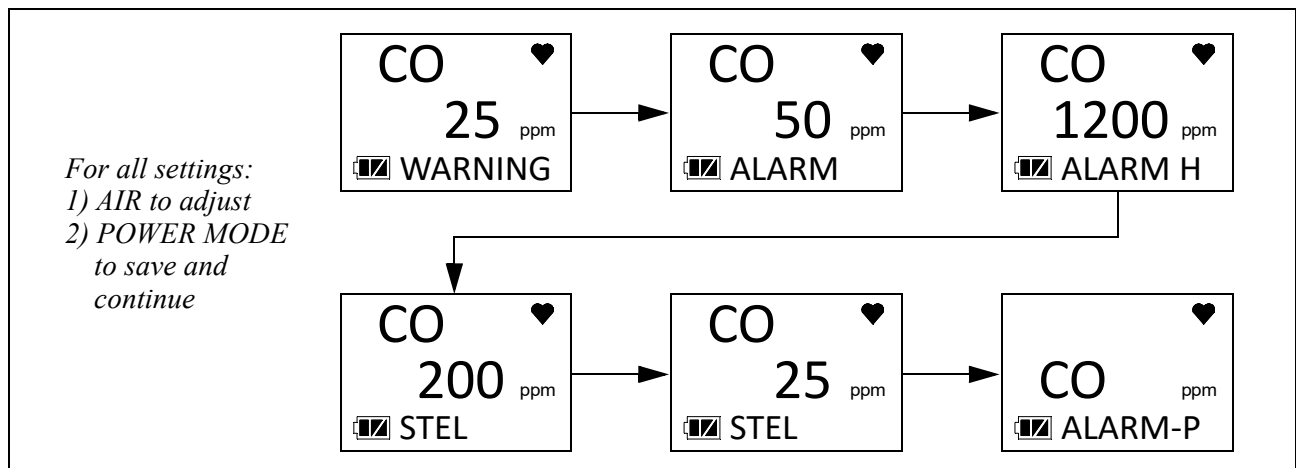

4. Use AIR to adjust the Warning setpoint. The alarm setpoint limitations are shown below.

Channel	Alarm Point Limitations
CO	$20 \text{ ppm} \leq \text{WARNING} \leq \text{ALARM} \leq \text{ALARM H} \leq 2000 \text{ ppm}$
O ₂	<ul style="list-style-type: none"> $0.0\% \leq \text{ALARM} \leq \text{WARNING} \leq 20.0\%$ $21.8\% \leq \text{ALARM H} \leq 40.0\%$

5. Press and release **POWER MODE** to save the setting.
6. Repeat Step 4 and Step 5 for the Alarm, Alarm H, STEL (CO only) and TWA (CO only) settings.
7. The instrument returns to the channel selection screen.
8. See “ESCAPE” on page 71 to return to User Mode.

Defaulting the Alarm Points

Defaulting the alarm points defaults them back to factory settings as outlined in Table 1 on page 8 or to the settings saved in the **SAVE-AP** item in Gas Select Mode if you performed a **SAVE-AP** operation.

1. After entering the **ALARM-P** menu, press AIR to scroll to **DEF.ALMP**.



2. Press POWER MODE to enter the **DEF.ALMP** item.
3. Press POWER MODE to perform an alarm default. Press AIR to return to the **DEF.ALMP** item in the **ALARM-P** menu.
4. The instrument asks if you're sure you want to default the alarm points.
5. Press POWER MODE to default the alarm points. Press AIR to return to the **DEF.ALMP** item in the **ALARM-P** menu.
6. See "ESCAPE" on page 71 to return to User Mode.

ESCAPE

1. While in the **ALARM-P** menu, press AIR to scroll to **ESCAPE**.
2. Press and release POWER MODE to return to the **ALARM--P** item in User Mode.
3. See "Entering Measuring Mode (START)" on page 77 to enter Measuring Mode.

Updating the Lunch Break Setting (LUNCH)

OFF (factory setting): The CX-04 automatically starts new TWA (CO only) and PEAK reading collection and resets the time in operation at startup.

ON: The Lunch Break Screen displays during startup. From this screen, you can choose to continue accumulating TWA (CO only) and PEAK readings and the time in operation from the last time the CX-04 was used or start collecting new readings and reset the time in operation.

1. While in User Mode, press AIR to scroll to **LUNCH**.

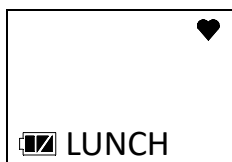

2. Press and release POWER MODE. The current setting flashes.
3. Use AIR to display the desired setting.

4. Press and release POWER MODE to save the setting and return to the **LUNCH** item in User Mode.
5. See “Entering Measuring Mode (START)” on page 77 to enter Measuring Mode.

Setting the Confirmation Beep and Non-Compliance Indicator (BEEP)

The **BEEP** menu has 3 items: **BEEP.SEL**, **BEEP.INT**, and **ESCAPE**.

1. While in User Mode, press AIR to scroll to **BEEP**.



2. Press and release POWER MODE. The **BEEP.SEL** item appears.



BEEP.SEL

BEEP.SEL defines what kind of confirmation or non-compliance indication you want to occur in Measuring Mode. The available choices are:

OFF (factory setting): The CX-04 does not provide a confirmation alert or non-compliance indicator.

LED: The CX-04’s LED double flashes as often as defined by the **BEEP.INT** parameter to verify that the instrument is operating.

BUZZER: The CX-04’s buzzer double beeps as often as defined by the **BEEP.INT** parameter to verify that the instrument is operating.

LED+BUZ: The CX-04’s LED double flashes and the buzzer double beeps as often as defined by the **BEEP.INT** parameter to verify that the instrument is operating.

BMP/CAL: If a bump test or a calibration is due and if **BP.EXPD** or **CAL.EXPD** is set to **CONFIRM** (factory setting) or **NONE**, the CX-04’s LED double flashes as often as defined by the **BEEP.INT** parameter to indicate a non-compliance. Once a bump test or calibration (depending on which is due) is done, the LED stop flashing.

1. While in the **BEEP** menu, press AIR to scroll to **BEEP.SEL**.



2. Press and release POWER MODE. The current setting flashes.
3. Use AIR to display the desired setting.
4. Press and release POWER MODE to save the setting and return to the **BEEP.SEL** item in the **BEEP** menu.
5. See “ESCAPE” on page 73 to return to User Mode.

BEEP.INT

The **BEEP.INT** parameter defines how often the confirmation alert or non-compliance indicator selected in **BEEP.SEL** occurs. This setting only applies if the **BEEP.SEL** parameter is set to something other than **OFF** (factory setting). The available choices are **0.5** minutes and **1-99** minutes in 1 minute increments. The factory setting is **5** minutes.

1. While in the **BEEP** menu, press AIR to scroll to **BEEP.INT**.



2. Press and release POWER MODE. The current setting flashes.
3. Use AIR to display the desired setting.
4. Press and release POWER MODE to save the setting and return to the **BEEP.INT** item in the **BEEP** menu.
5. See “ESCAPE” on page 73 to return to User Mode.

ESCAPE

1. While in the **BEEP** menu, press AIR to scroll to **ESCAPE**.
2. Press and release POWER MODE to return to the **BEEP** item in User Mode.
3. See “Entering Measuring Mode (START)” on page 77 to enter Measuring Mode.

Updating the Backlight Time (BL TIME)

This setting defines how long the LCD backlight stays on when you press any button. The minimum setting is **OFF**; the maximum setting is **255** seconds. The factory setting is **30** seconds.

1. While in User Mode, press AIR to scroll to **BL TIME**.



2. Press and release POWER MODE. The current setting flashes.

3. Use AIR to display the desired setting.
4. Press and release POWER MODE to save the setting and return to the **BL TIME** item in User Mode.
5. See “Entering Measuring Mode (START)” on page 77 to enter Measuring Mode.

Turning the Key Tone On/Off (KEY.TONE)

ON (factory setting): The instrument beeps when a button is pressed.

OFF: The instrument does not beep when a button is pressed.

1. While in User Mode, press AIR to scroll to **KEY.TONE**.



2. Press and release POWER MODE. The current setting flashes.
3. Use AIR to display the desired setting.
4. Press and release POWER MODE to save the setting and return to the **KEY.TONE** item in User Mode.
5. See “Entering Measuring Mode (START)” on page 77 to enter Measuring Mode.

Display Mode Items (DISP.SET)

OFF: **USER ID**, **STN ID**, and **BUZZ.VOL** screens do not appear in Display Mode.

ON (factory setting): **BUZZ.VOL** screen appears in Display Mode. **USER ID** and **STN ID** screens appear in Display Mode if **ID DISP** in Maintenance Mode is also set to **ON** (factory setting is **OFF**).

1. While in User Mode, press AIR to scroll to **DISP.SET**.



2. Press and release POWER MODE. The current setting flashes.
3. Use AIR to display the desired setting.
4. Press and release POWER MODE to save the setting and return to the **DISP.SET** item in User Mode.
5. See “Entering Measuring Mode (START)” on page 77 to enter Measuring Mode.

Zero Suppression (ZERO.SUP)

This item only appears if **ZSUP.DSP** is set to **ON** in Maintenance Mode (factory setting is **OFF**). The **ZERO.SUP** setting is not intended for field adjustment. The default setting is **ON**.

Channel	Zero Suppression Value
CO	2 ppm
O ₂	0.5% volume

Zero Follower (ZERO.FLW)

This item only appears if **ZFLW.DSP** is set to **ON** in Maintenance Mode (factory setting is **OFF**). The **ZERO.FLW** setting is not intended for field adjustment. The default setting is **ON**. The oxygen channel does not support zero follower functionality.

Turning Easy Calibration On/Off (E-CAL)

OFF (factory setting): Auto Calibration (**A-CAL**) item appears in **GAS CAL** menu instead of Easy Calibration (**E-CAL**).

XX seconds: Easy Calibration (**E-CAL**) item appears in **GAS CAL** menu instead of Auto Calibration (**A-CAL**). During a calibration, the instrument counts down from the number of seconds you select.

1. While in User Mode, press AIR to scroll to **E-CAL**.

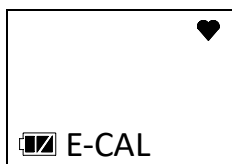

2. Press and release POWER MODE. The current setting flashes.
3. Use AIR to display the desired setting.
4. Press and release POWER MODE to save the setting and return to the **E-CAL** item in User Mode.
5. See “Entering Measuring Mode (START)” on page 77 to enter Measuring Mode.

Setting the Date/Time (DATE)

1. While in User Mode, place the cursor next to **DATE**.



2. Press and release POWER MODE. The date and time display with the year flashing.

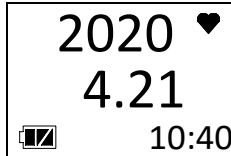

3. Use AIR to display the desired year.
4. Press and release POWER MODE to save the setting. The month setting flashes.
5. Repeat Step 3 and Step 4 to enter the month, day, hours, and minutes settings. The date and time are saved and the instrument returns to the **DATE** item in User Mode.
6. See “Entering Measuring Mode (START)” on page 77 to enter Measuring Mode.

Turning the Password On/Off (PASS-W)

ON: The CX-04 prompts you for a password when you enter User Mode. The factory-set password is **0405** but it can be changed.

OFF (factory setting): No password is required to enter User Mode.

1. While in User Mode, press AIR to scroll to **PASS-W**.

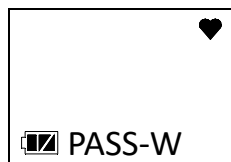

2. Press and release POWER MODE. The current setting flashes.
3. Use AIR to display the desired setting.
4. If you selected **OFF**, press and release POWER MODE to save the setting and return to the **PASS-W** item in User Mode.

If you selected **ON**, continue with Step 5.

5. Press and release POWER MODE. The Set Password Screen appears. The current password appears and the first digit flashes.

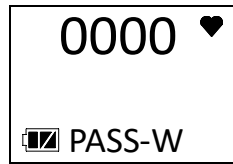

6. Use AIR to display a number from 0 to 9.
7. Press and release POWER MODE to enter the selection and advance to the next number. To go back a number, press and hold AIR and POWER MODE for a few seconds.
8. Repeat Step 6 and Step 7 to select the remaining numbers. When you press and release POWER MODE to enter the last number, the password is saved and the instrument returns to the **PASS-W** item in User Mode.
9. See “Entering Measuring Mode (START)” on page 77 to enter Measuring Mode.

Viewing the ROM/SUM (ROM/SUM)

The **ROM/SUM** screen shows the instrument’s firmware version and firmware checksum.

1. While in User Mode, press AIR to scroll to **ROM/SUM**.

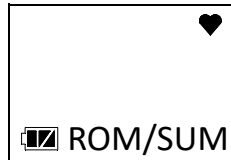

2. Press and release POWER MODE. The screen shows the ROM/SUM. The ROM is the top value and the SUM is the bottom value.

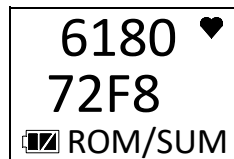

3. Press and release POWER MODE to return to the **ROM/SUM** item in User Mode.
4. See “Entering Measuring Mode (START)” on page 77 to enter Measuring Mode.

Entering Measuring Mode (START)

1. While in User Mode, press AIR to scroll to **START**.



2. Press and release POWER MODE. The instrument begins its warmup sequence.

Chapter 6: Maintenance

Overview

This chapter describes troubleshooting procedures for the CX-04. It also includes procedures for replacing the batteries and replacing various consumable parts.

WARNING: *RKI Instruments recommends that service, calibration, and repair of RKI gas detectors be performed by personnel properly trained for this work. Replacing the sensor and other parts with original equipment does not affect the intrinsic safety of the instrument.*

AVERTISSEMENT: *RKI Instruments recommande que le service, l'étalonnage et la réparation des détecteurs de gaz RKI soient effectués par du personnel dûment formé à ces travaux. Le remplacement du capteur et d'autres pièces par l'équipement d'origine n'affecte pas la sécurité intrinsèque de l'instrument.*

Troubleshooting

The troubleshooting table describes error messages, symptoms, probable causes, and recommended action for problems you may encounter with the CX-04.

Table 10: Troubleshooting the CX-04

Symptoms	Probable Causes	Recommended Action
<ul style="list-style-type: none">The LCD is blank.	<ul style="list-style-type: none">The unit got turned off.The batteries needs to be replaced.The battery cover may not be completely closed.	<ol style="list-style-type: none">To turn on the unit, press and briefly hold POWER MODE.Replace the batteries.Be sure the battery cover is completely closed and that the screw is tight.If the difficulties continue, contact RKI Instruments, Inc. for further instruction.
<ul style="list-style-type: none">The LCD shows an abnormally high reading but other gas detection instruments do not.	<ul style="list-style-type: none">Charcoal filter needs to be replaced.The CX-04 needs to be recalibrated.The sensor needs replacement.	<ol style="list-style-type: none">Replace the charcoal filter.Recalibrate the unit.If the difficulties continue, replace the sensor and calibrate.If the difficulties continue, contact RKI Instruments, Inc. for further instruction.

Table 10: Troubleshooting the CX-04

Symptoms	Probable Causes	Recommended Action
<ul style="list-style-type: none"> • Calibration fails. 	<ul style="list-style-type: none"> • The calibration value does not match the cylinder gas concentration. • The sample gas is not reaching the sensor because of a bad connection. • The calibration cylinder is out of gas or is outdated. • The sensor needs replacement. 	<ol style="list-style-type: none"> 1. Make sure the CX-04 has been properly set up for calibration. 2. Check all calibration tubing for leaks or for any bad connections. 3. Verify that the calibration cylinder contains an adequate supply of fresh test sample. 4. If the fail condition continues, replace the sensor. 5. If the difficulties continue, contact RKI Instruments, Inc. for further instruction.
<ul style="list-style-type: none"> • Heart symbol at the top of the screen becomes steadily on or disappears. 	<ul style="list-style-type: none"> • A microprocessor error has occurred. 	<ul style="list-style-type: none"> • Contact RKI Instruments, Inc. for further instruction.

Replacing the Batteries (Alkaline or Ni-MH)

WARNING: *To prevent ignition of a hazardous atmosphere, batteries must only be changed in an area known to be nonhazardous.*

AVERTISSEMENT: *Pour éviter l'inflammation d'une atmosphère dangereuse, la batterie ne doit être remplacée que dans une zone non dangereuse.*

WARNING: *Use only Duracell MN2400 or PC2400 or Eneloop BK-4MCC batteries to maintain the QPS classification of the CX-04. Use of other batteries will void the QPS classification and may void the warranty. Do not mix old/new or different types of batteries.*

AVERTISSEMENT: *Utiliser uniquement des piles Duracell MN 2400 ou PC 2400 ou Eneloop BK-4MCC de maintenir la classification QPS de la CX-04. L'utilisation d'autres piles annule la classification QPS et peut annuler la garantie. Ne mélangez pas les anciennes/nouvelles ou différents types de piles.*

Replace the batteries when the last bar in the battery icon is flashing.

1. Make sure the CX-04 is off.

2. Release the side of the alligator or belt clip that is opposite the hinge. You may need to use a screwdriver to pry it open.

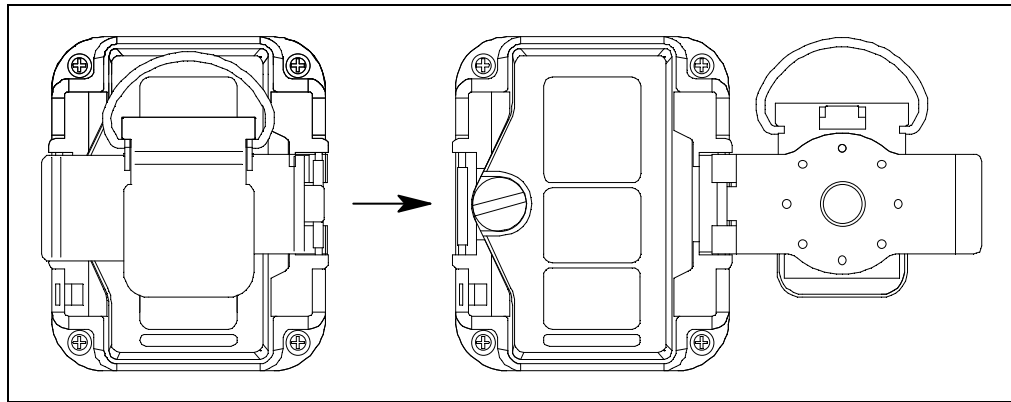

Figure 9: Releasing the Alligator or Belt Clip

3. Rotate the captive battery cover screw counterclockwise.

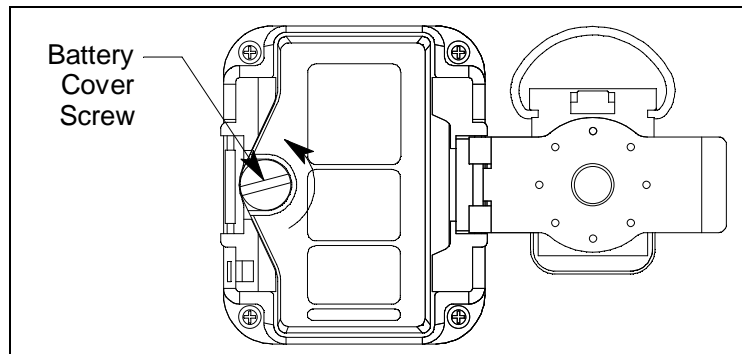

Figure 10: Unscrew Battery Cover Screw

4. Remove the battery cover.
5. Remove the old batteries.

NOTE: New batteries must be installed within 5 minutes to avoid having to reset the date/time.

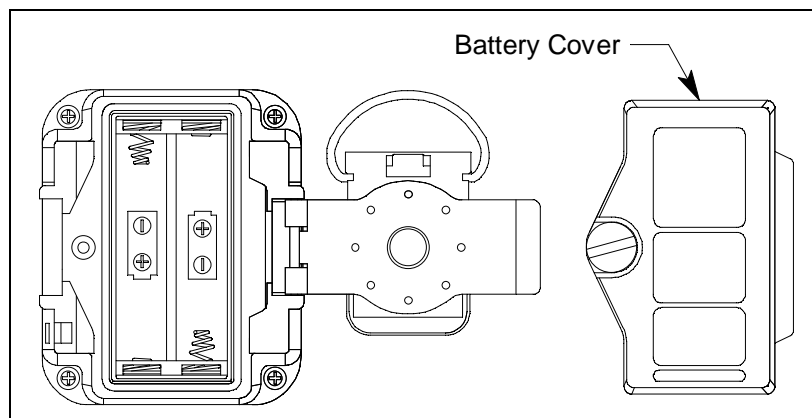

Figure 11: Battery Cover Removal

6. Install the new AAA batteries. Follow the diagram shown in the battery compartment.

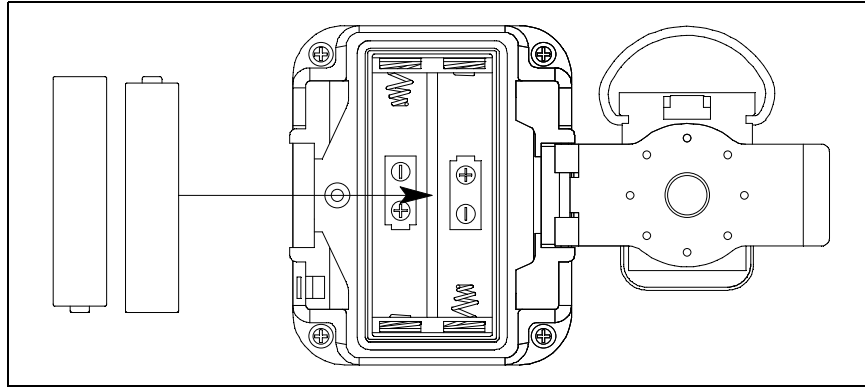

Figure 12: Installing New Batteries

7. Reinstall the battery cover and tighten the battery cover screw.
8. If the instrument has been without batteries for more than 5 minutes, the date and time are reset and need to be set again. When the new batteries are installed, the instrument automatically turns on and displays the Date/Time Screen. Set the date and time as described on page 76. Once the date and time are set, the instrument begins its warmup sequence. If you do not set the date and time within 30 seconds, the instrument automatically begins its warmup sequence.

Recharging the Batteries (Ni-MH Batteries Only)

Any battery charger capable of charging AAA Ni-MH batteries can be used to recharge the CX-04's Ni-MH batteries. RKI Instruments, Inc. recommends using one of the chargers specified on page 89.

WARNING: To prevent ignition of a hazardous atmosphere, batteries must only be charged in an area known to be nonhazardous.

1. Remove the batteries from the CX-04 as described in Step 1 - Step 5 on page 80.
2. Install the Ni-MH batteries in the charger. See the battery charger's manual for charging instructions.
3. Put the batteries back in the CX-04 and reinstall the battery cover.

Replacing the Charcoal Filter

1. Verify that the CX-04 is off.
2. Remove the rubber boot, if installed.

3. Use a small Phillips screwdriver to unscrew the 4 screws that attached the front case to the rear case.

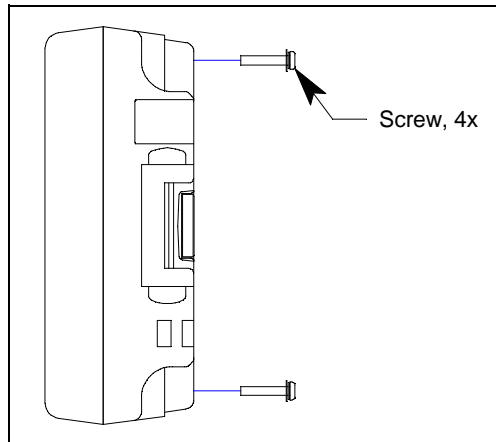

Figure 13: Unscrewing Case Screws

4. Turn the instrument right side up. The screws are not captive and may fall out. Be sure not to lose them.
5. Remove the front case from the rear case.

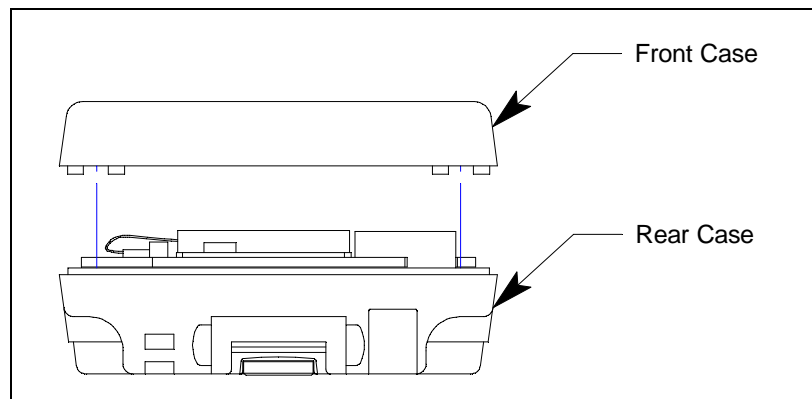

Figure 14: Case Separation

6. Turn the front case upside down.
7. If the sensor stayed in the front case, remove the sensor.

8. The charcoal filter sits in the middle of a black gasket. Pry the charcoal filter out of the gasket.

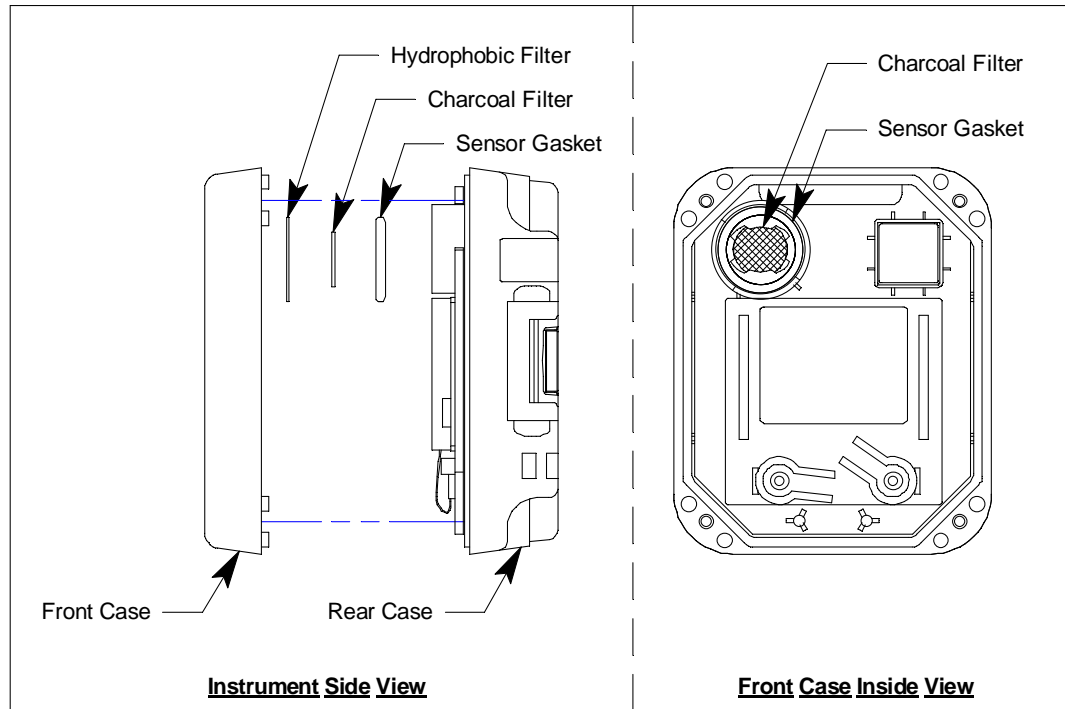

Figure 15: Charcoal Filter Location

9. Install a new charcoal filter. If the gasket got removed, install it with the flat side facing the white hydrophobic filter.
10. If necessary, put the sensor in the socket on the rear case. The colored side faces away from the rear case and the slots in the sensor line up with tabs in the socket.

CAUTION: Forcing a sensor into a socket without lining the sensor slots up with the socket tabs may damage the sensor or socket.

11. Reinstall the front case to the rear case.
12. Reinstall the 4 screws that were removed in Step 3.
13. Reinstall the rubber boot, if being used.

Replacing the Hydrophobic Filter

1. Verify that the CX-04 is off.
2. Remove the rubber boot, if installed.
3. Use a small Phillips screwdriver to unscrew the 4 screws that attached the front case to the rear case.

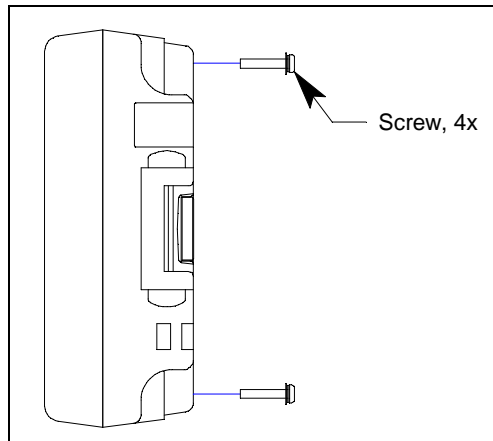

Figure 16: Unscrewing Case Screws

4. Turn the instrument right side up. The screws are not captive and may fall out. Be sure not to lose them.
5. Remove the front case from the rear case.

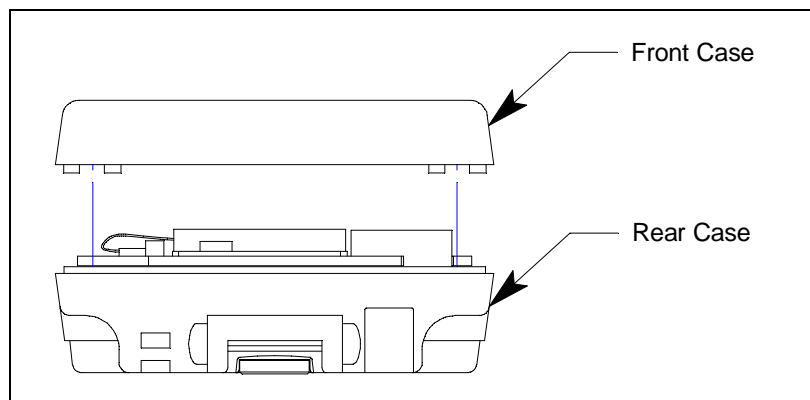

Figure 17: Case Separation

6. Turn the front case upside down.
7. If the sensor stayed in the front case, remove the sensor.
8. Carefully remove the sensor gasket and the black charcoal filter that sits in the middle of the sensor gasket.

9. Remove the white hydrophobic filter.

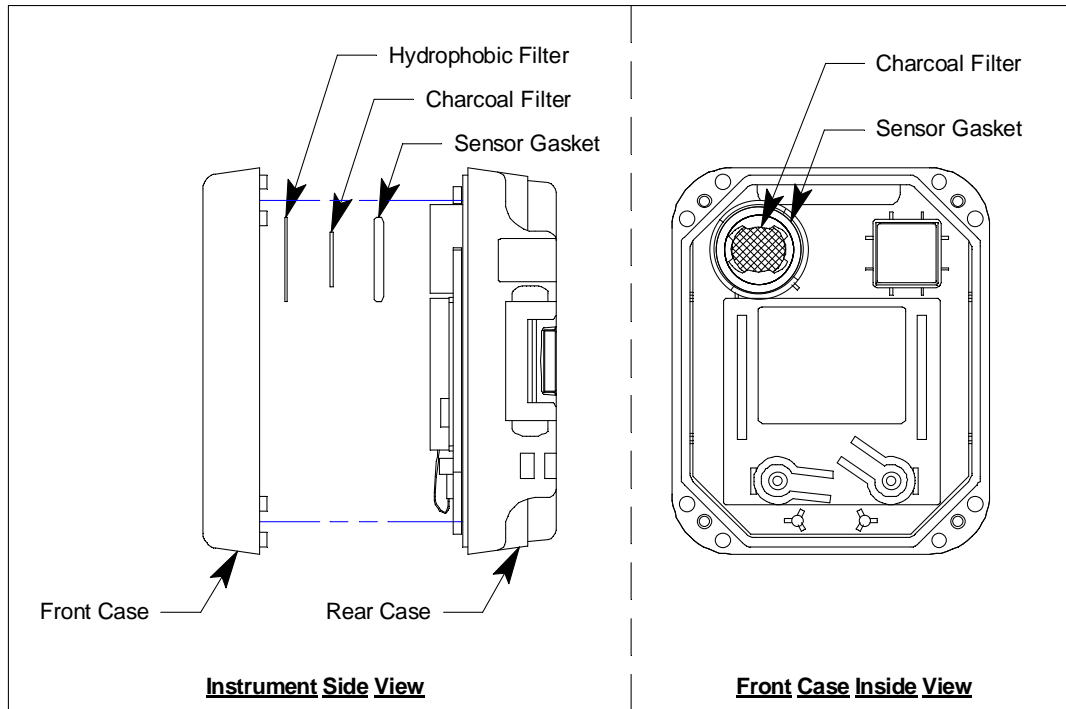

Figure 18: Hydrophobic Filter Location

10. Install a new hydrophobic filter.
11. Reinstall the sensor gasket with the flat side facing the white hydrophobic filter.
12. If the charcoal filter came loose, reinstall it in the middle of the sensor gasket.
13. If necessary, put the sensor in the socket on the rear case. The colored side faces away from the rear case and the slots in the sensor line up with tabs in the socket.

CAUTION: Forcing a sensor into a socket without lining the sensor slots up with the socket tabs may damage the sensor or socket.

14. Reinstall the front case to the rear case.
15. Reinstall the 4 screws that were removed in Step 3.
16. Reinstall the rubber boot, if being used.

Replacing the Sensor

1. Verify that the CX-04 is off.
2. Remove the rubber boot, if installed.
3. Use a small Phillips screwdriver to unscrew the 4 screws that attached the front case to the rear case.

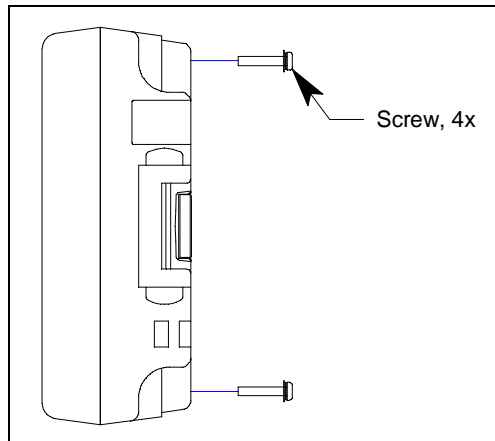

Figure 19: Unscrewing Case Screws

4. Turn the instrument right side up. The screws are not captive and may fall out. Be sure not to lose them.
5. Remove the front case from the rear case.

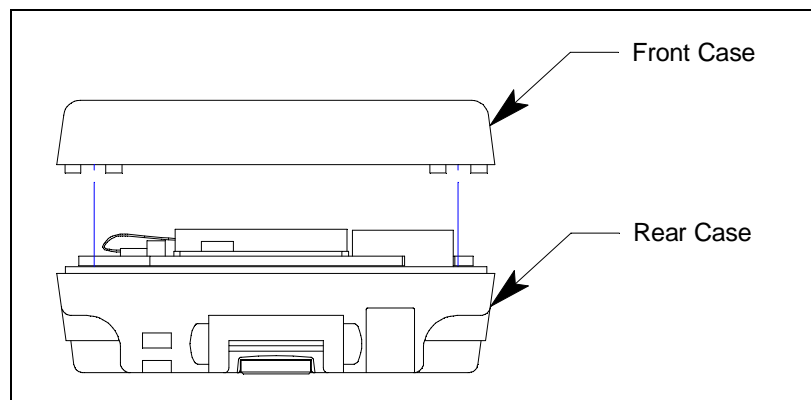

Figure 20: Case Separation

6. Turn the front case upside down.
7. Remove the old sensor. It will either be in its rear case socket or it will be stuck to the sensor gasket in the front case.

8. Install the new sensor in the socket on the rear case. The colored side faces away from the rear case and the slots in the sensor line up with tabs in the socket.

CAUTION: Forcing a sensor into a socket without lining the sensor slots up with the socket tabs may damage the sensor or socket.

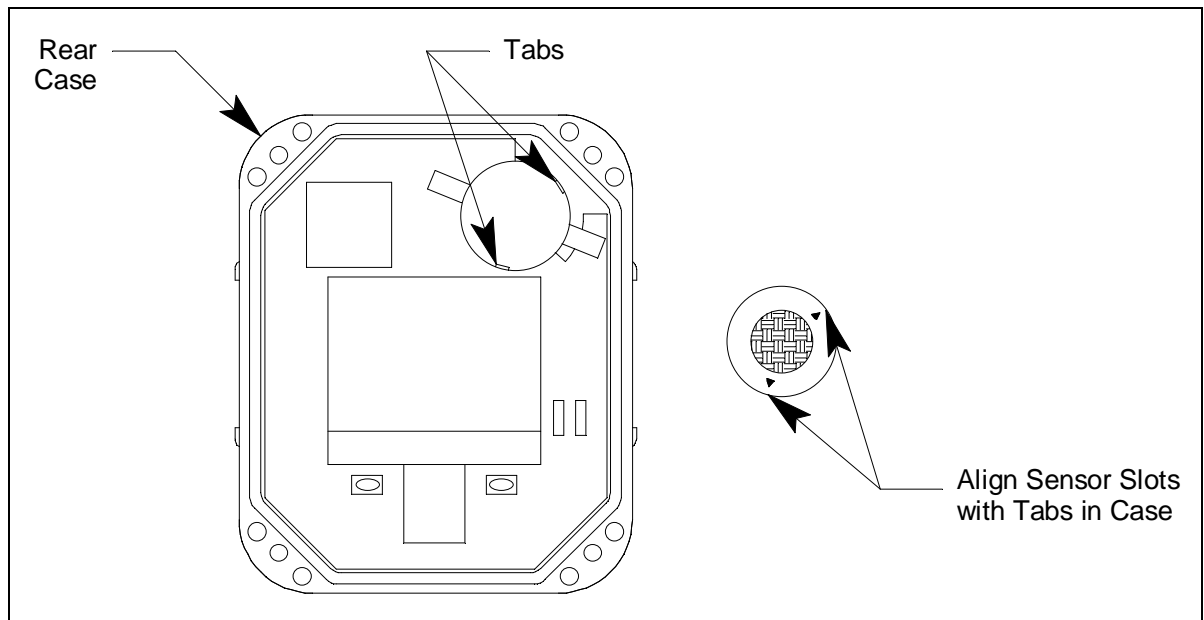

Figure 21: Sensor Location

9. Reinstall the front case to the rear case.
10. Reinstall the 4 screws that were removed in Step 3.
11. Reinstall the rubber boot, if being used.
12. Calibrate the new sensor as described on page 49.

Chapter 7: General Parts List

Table 11 lists part numbers for the CX-04's replacement parts and accessories.

Table 11: General Parts List

Part Number	Description
06-1248RK-03	Calibration kit tubing, 3 foot length
07-6033	Sensor gasket
10-1105-01	Screw, for securing front case to rear case
13-0112RK	Wrist strap
13-0122	Belt clip
13-0128	Alligator clip
13-0204RK	Pins for connecting alligator clip/belt clip
20-0325	Rubber boot
33-0175	Hydrophobic filter
33-7100	Charcoal filter disk, 5 pack
47-5084RK	USB/IrDA adapter module, Legasic, for use with all premier portables (without USB cable)
47-5084RK-01	USB/IrDA adapter assembly, Legasic, for use with all premier portables (with module and USB cable)
47-5085RK	Cable, USB A to USB mini, 6 feet, for 47-5084RK USB/IrDA adapter module
49-1110RK	AAA size alkaline battery
49-1312	AAA size Ni-MH battery
49-3105RK	4-battery AA/AAA charger with AC adapter and DC vehicle adapter
49-3106RK	12-battery AA/AAA charger with AC adapter
71-0559	Operator's Manual, CX-04 (this document)
71-0525	Operator's Manual, 04 Series Datalogging Program
71-0526	Operator's Manual, 04 Series Setup Program
81-0062RK-01	Calibration cylinder, 50 ppm CO in N ₂ , 34 liter steel
81-0062RK-03	Calibration cylinder, 50 ppm CO in N ₂ , 103 liter
81-0076RK-01	Calibration cylinder, zero air, 34 liter steel
81-0076RK-03	Calibration cylinder, zero air, 103 liter

Table 11: General Parts List (Continued)

Part Number	Description
81-1050RK-25	Regulator, fixed flow, 0.25 LPM, with gauge and knob, for 17 liter and 34 liter steel cylinders (cylinders with external threads)
81-1051RK-25	Regulator, fixed flow, 0.25 LPM, with gauge and knob, for 34 liter aluminum, 58 liter, and 103 liter cylinders (cylinders with internal threads)
81-1194	Calibration cup
81-CX04-LV	Calibration kit: 34 liter steel cylinder of 50 ppm CO in N ₂ , regulator, tubing, calibration cup, case
ESR-X1DP-CX	Dual carbon monoxide (CO) and oxygen (O ₂) sensor

Appendix A: Maintenance Mode

Overview

This appendix describes the CX-04 in Maintenance Mode. The CX-04 is factory-set to suit most applications. Update settings in Maintenance Mode only if required for your specific application. Maintenance Mode items and their factory settings are listed in Table 12 below.

Table 12: Maintenance Mode Menu Items

Maintenance Mode Menu Item	Description		
GAS CAL (page 94)	Perform an air adjust, perform a span adjustment, change the calibration values.		
	AIR	Perform a fresh air adjustment.	
	A-CAL or E-CAL depending on E-CAL User Mode setting	Perform a span adjustment and set the calibration gas concentration.	
		A-CAL (or E-CAL)	Perform an automatic span adjustment.
		START	Begin the warmup sequence and enter Measuring Mode.
		CAL-P	Set the calibration gas concentration.
		CYL SEL	Assign a cylinder (A-E) to each gas. CO and O ₂ are assigned to Cylinder A by default.
		ESCAPE	Return to the A-CAL item in the GAS CAL menu.
ESCAPE	Return to the GAS CAL item in Maintenance Mode.		
GAS.TEST (page 94)	Apply gas to test sensor response and observe alarm indications without an alarm event being recorded.		
SEN.DATE (page 96)	View and/or set the replacement date for the sensor and the batteries.		
BUMP (page 96)	Perform a bump test.		
LATCH (page 97)	<p><u>ON (factory setting)</u>: The CX-04 remains in alarm until the alarm condition passes and POWER MODE is pressed.</p> <p><u>OFF</u>: The CX-04 automatically resets an alarm when the alarm condition passes.</p>		
D.ZERO (page 97)	<p><u>ON (factory setting)</u>: You can manually perform a fresh air adjust in Measuring Mode by pressing AIR.</p> <p><u>OFF</u>: You cannot manually perform a fresh air adjust in Measuring Mode by pressing AIR.</p>		

Table 12: Maintenance Mode Menu Items

Maintenance Mode Menu Item	Description
A.ZERO (page 98)	<p><u>ON</u>: The CX-04 asks if you want to perform a fresh air adjustment at the end of the startup sequence.</p> <p><u>OFF (factory setting)</u>: The CX-04 does not ask if you want to perform a fresh air adjustment at the end of the startup sequence.</p>
ID DISP (page 98)	<p><u>ON</u>: User ID and Station ID screens appear in startup sequence. IDs can be changed in Display Mode if DISP.SET in User Mode is also set to ON.</p> <p><u>OFF (factory setting)</u>: User ID and Station ID screens do not appear in startup sequence. IDs cannot be changed in Display Mode.</p>
ZERO.SUP (page 99)	<p><u>ON (factory setting)</u>: Not intended for field adjustment. The suppression values are :</p> <p>CO: 2 ppm</p> <p>O₂: 0.5% volume</p>
ZERO.FLW (page 99)	<p><u>ON (factory setting)</u>: Not intended for field adjustment. Oxygen channel does not support zero follower functionality.</p>
ZSUP.DSP (page 99)	<p><u>ON</u>: Zero suppression item appears in User Mode.</p> <p><u>OFF (factory setting)</u>: Zero suppression item does not appear in User Mode. (Zero suppression item is always available in Maintenance Mode)</p>
ZFLW.DSP (page 99)	<p><u>ON</u>: Zero follower item appears in User Mode.</p> <p><u>OFF (factory setting)</u>: Zero follower item does not appear in User Mode. (Zero follower item is always available in Maintenance Mode)</p>
CYL.DISP (page 99)	<p><u>ON (factory setting)</u>: CYL SEL item appears in GAS CAL.</p> <p><u>OFF</u>: CYL SEL item does not appear in GAS CAL. (RKI Instruments, Inc. does not recommend adjusting this setting.)</p>
DATE (page 100)	<p>Set the current date and time.</p>
PASS-W (page 100)	<p><u>ON (factory setting)</u>: Maintenance Mode is password-protected. Factory-set password is 0400.</p> <p><u>OFF</u>: Maintenance Mode is not password-protected.</p>
ROM/SUM (page 101)	<p>View the firmware information for the CX-04's sensor board and main board.</p>
M.DEF (page 102)	<p>Set all parameters back to their RKI factory settings.</p>
START (page 102)	<p>Press and release POWER MODE to begin the warmup sequence and enter Measuring Mode.</p>

Entering Maintenance Mode

WARNING: *The CX-04 is not in operation as a gas detector while in Maintenance Mode.*

1. Take the CX-04 to a non-hazardous location and turn it off if it is on.
2. Press and hold AIR, then press and hold POWER MODE. You will hear a beep after one second. Continue to hold the buttons down.
3. When you hear a second beep, release the buttons.
4. The screen that appears depends on the setting of Maintenance Mode's **PASS-W** item.
If **PASS-W** is set to **OFF**, continue with Step 8.
If **PASS-W** is set to **ON** (factory setting), continue with Step 5.

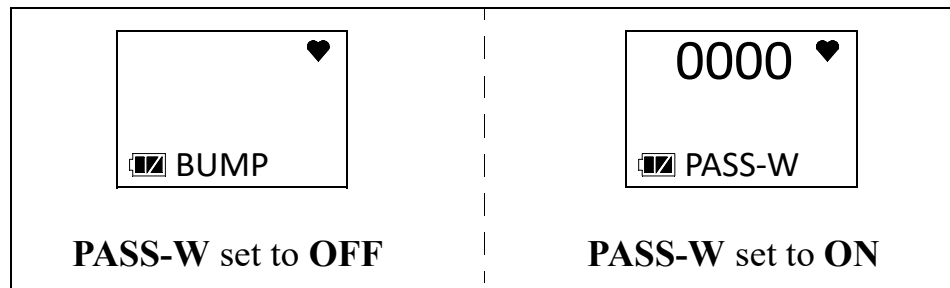

5. If **PASS-W** is set to **ON** in Maintenance Mode, a password screen appears and the first digit is flashing. The factory-set password is **0400** but it can be changed.
6. Use AIR to select each password number then press POWER MODE to save it and move on to the next number. To go back a number, press and hold AIR and POWER MODE for a few seconds. To reverse the direction of change (ie. from increasing to decreasing or vice versa):
 - a. Press and hold AIR.
 - b. Immediately press POWER MODE and then release both buttons.
7. Continue to Step 6.
8. The **GAS CAL** item displays.



9. Use AIR to move through the Maintenance Mode items.

Tips for Using Maintenance Mode

- To scroll from one item to the next, press and release AIR. To reverse the scrolling direction:
 - a. Press and hold AIR.
 - b. Immediately press POWER MODE and then release both buttons.
 - c. The scrolling direction returns to the original direction when you exit and reenter a menu.
- To skip an item when a question is asked, press and release AIR.
- To enter an item and to save any changes, press and release POWER MODE.
- To change a flashing parameter, press and release AIR. To reverse the direction of change (ie. from increasing to decreasing or vice versa):
 - a. Press and hold AIR.
 - b. Immediately press POWER MODE and then release both buttons.
- To exit an entered item without saving a change, press and hold AIR and POWER MODE for a few seconds.

Performing a Calibration (GAS CAL)

See page 49 for a description of the GAS CAL item.

Performing a Gas Test (GAS.TEST)

The GAS.TEST item allows you to apply gas to the instrument and see all alarm indications except for the buzzer indication. There is no buzzer indication in the GAS.TEST menu even though the buzzer sounds in the event of a real gas alarm condition while in Measuring Mode. A gas test is not saved in logged data.

Preparing for a Gas Test

To perform a gas test on the CX-04, you need:

- A calibration gas cylinder. The concentrations should be above the alarm condition you want to check. Standard alarm points are listed on page 8.
 - A 0.25 LPM fixed flow regulator
 - Non-absorbent tubing
 - Calibration cup
1. Confirm that the regulator knob is turned all the way clockwise. Screw the 0.25 LPM fixed flow regulator onto the calibration cylinder.

2. Install the calibration cup onto the CX-04. Be sure the calibration cup is installed in the correct direction and that it is pushed on all the way.

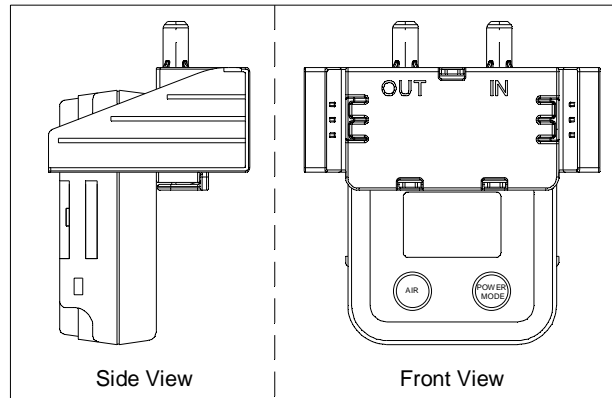

3. Use the tubing to connect the regulator to the inlet of the calibration cup (labeled “IN”).

Performing a Gas Test

1. While in Maintenance Mode, press AIR to scroll to **GAS.TEST**.



2. Press and release POWER MODE. The current gas reading displays. The bottom of the LCD alternates between “GAS.TEST” and “BUZZ.OFF”.

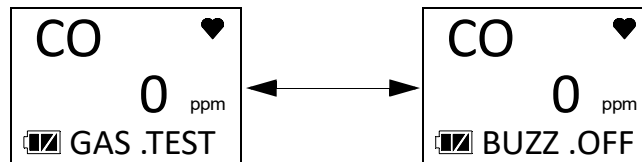

3. Turn the regulator knob counterclockwise to open the regulator.
4. The instrument initiates alarm indications except for the buzzer. There is no buzzer indication in the **GAS.TEST** menu even though the buzzer sounds in the event of a real gas alarm condition.
5. Turn the regulator knob clockwise to close the regulator.
6. Unscrew the regulator from the calibration cylinder.
7. Remove the calibration cup from the CX-04.
8. Store the calibration kit in a safe and convenient place.
9. Press and release POWER MODE to return to the **GAS.TEST** item in Maintenance Mode.
10. See “Entering Measuring Mode (START)” on page 102 to enter Measuring Mode.

Sensor/Battery Replacement Date (SEN.DATE)

The **SEN.DATE** item allows you to keep track of when the sensor and the batteries were replaced.

1. While in Maintenance Mode, press AIR to scroll to **SEN.DATE**.

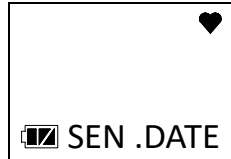

2. Press and release POWER MODE. The sensor replacement date displays.
3. Use AIR to scroll to the item whose replacement date you want to view or change.

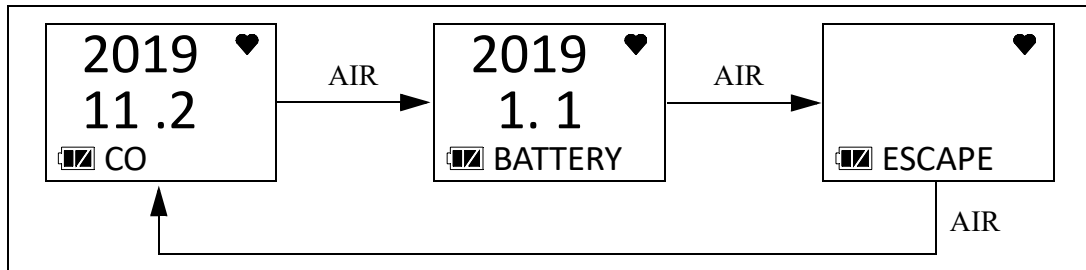

4. To change the replacement date:
 - a. With the desired item displayed, press and release POWER MODE.
 - b. Press and release POWER MODE again to set the replacement date to the current date.
5. Use the AIR button to scroll to **ESCAPE**.
6. Press and release POWER MODE to return to the **SEN.DATE** item in Maintenance Mode.
7. See “Entering Measuring Mode (START)” on page 102 to enter Measuring Mode.

Performing a Bump Test (BUMP)

See “Performing a Bump Test (BUMP)” on page 43 for a description of the **BUMP** item.

Setting Alarms to Latching or Self-Resetting (LATCH)

ON (factory setting): The CX-04 remains in alarm until the alarm condition passes *and* POWER MODE is pressed.

OFF: The CX-04 automatically resets an alarm when the alarm condition passes.

1. While in Maintenance Mode, press AIR to scroll to **LATCH**.



2. Press and release POWER MODE. The current setting flashes.
3. Use AIR to display the desired setting.
4. Press and release POWER MODE to save the setting and return to the **LATCH** item in Maintenance Mode.
5. See “Entering Measuring Mode (START)” on page 102 to enter Measuring Mode.

Turning the Demand Zero Function On/Off (D.ZERO)

ON (factory setting): You can manually perform a fresh air adjust in Measuring Mode by pressing AIR.

OFF: You cannot manually perform a fresh air adjust in Measuring Mode.

1. While in Maintenance Mode, press AIR to scroll to **D.ZERO**.

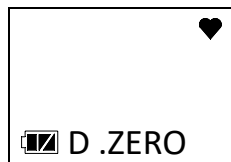

2. Press and release POWER MODE. The current setting flashes.
3. Use AIR to display the desired setting.
4. Press and release POWER MODE to save the setting and return to the **D.ZERO** item in Maintenance Mode.
5. See “Entering Measuring Mode (START)” on page 102 to enter Measuring Mode.

Turning the Auto Zero Function On/Off (A.ZERO)

ON: The CX-04 asks if you want to perform a fresh air adjustment at the end of the startup sequence.

OFF (factory setting): The CX-04 does not ask if you want to perform a fresh air adjustment at the end of the startup sequence.

1. While in Maintenance Mode, press AIR to scroll to **A.ZERO**.

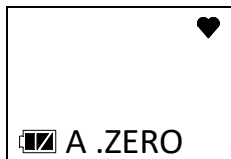

2. Press and release POWER MODE. The current setting flashes.
3. Use AIR to display the desired setting.
4. Press and release POWER MODE to save the setting and return to the **A.ZERO** item in Maintenance Mode.
5. See “Entering Measuring Mode (START)” on page 102 to enter Measuring Mode.

Turning the ID Display Function On/Off (ID DISP)

ON: The User ID and Station ID screens appear in the startup sequence. If **DISP.SET** in User Mode is also set to **ON**, then the IDs can be changed in Display Mode.

OFF (factory setting): The User ID and Station ID screens do not appear in the startup sequence and the IDs cannot be changed in Display Mode.

1. While in Maintenance Mode, press AIR to scroll to **ID DISP**.



2. Press and release POWER MODE. The current setting flashes.
3. Use AIR to display the desired setting.
4. Press and release POWER MODE to save the setting and return to the **ID DISP** item in Maintenance Mode.
5. See “Entering Measuring Mode (START)” on page 102 to enter Measuring Mode.

Turning the Zero Suppression On/Off (ZERO.SUP)

The **ZERO.SUP** setting is not intended for field adjustment. The default setting is **ON**.

Channel	Zero Suppression Value
CO	2 ppm
O ₂	0.5% volume

Turning the Zero Follower On/Off (ZERO.FLW)

The **ZERO.FLW** setting is not intended for field adjustment. The default setting is **ON**. The oxygen channel does not support zero follower functionality.

User Mode Zero Suppression (ZSUP.DSP)

ON: Zero suppression item appears in User Mode.

OFF (factory setting): Zero suppression item does not appear in User Mode. The zero suppression item is always available in Maintenance Mode.

It is not normally necessary to have the zero suppression item appear in User Mode. Contact RKI Instruments before turning this setting on.

User Mode Zero Follower (ZFLW.DSP)

ON: Zero follower item appears in User Mode.

OFF (factory setting): Zero follower item does not appear in User Mode. The zero follower item is always available in Maintenance Mode.

It is not normally necessary to have the zero follower item appear in User Mode. Contact RKI Instruments before turning this setting on.

Cylinder Setting (CYL.DISP)

ON (factory setting): **CYL SEL** item appears in User and Maintenance Modes' **GAS CAL** item.

OFF: **CYL SEL** item does not appear in User and Maintenance Modes' **GAS CAL** item.

Setting the Date/Time (DATE)

1. From the main menu, place the cursor next to **DATE**.



2. Press and release POWER MODE. The date and time display with the year flashing.

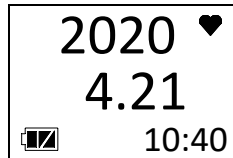

3. Use AIR to display the desired year.
4. Press and release POWER MODE to save the setting. The month setting flashes.
5. Repeat Step 3 and Step 4 to enter the month, day, hours, and minutes settings. The date and time are saved and the instrument returns to the **DATE** item in Maintenance Mode.
6. See “Entering Measuring Mode (START)” on page 102 to enter Measuring Mode.

Turning the Password On/Off (PASS-W)

ON (factory setting): The CX-04 prompts you for a password when you enter Maintenance Mode. The factory-set password is **3000** but it can be changed.

OFF: No password is required to enter Maintenance Mode.

1. While in Maintenance Mode, press AIR to scroll to **PASS-W**.

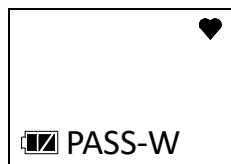

2. Press and release POWER MODE. The current setting flashes.
3. Use AIR to display the desired setting.
4. If you selected **OFF**, press and release POWER MODE to save the setting and return to the **PASS-W** item in User Mode.
If you selected **ON**, continue with Step 5.

5. Press and release POWER MODE. The Set Password Screen appears. The current password displays and the first digit flashes.

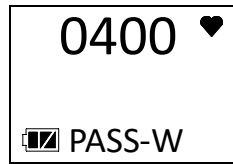

6. Use AIR to display a number from 0 to 9.
7. Press and release POWER MODE to enter the selection and advance to the next number. To go back a number, press and hold AIR and POWER MODE for a few seconds.
8. Repeat Step 6 and Step 7 to select the remaining numbers. When you press and release POWER MODE to enter the last number, the password is saved and the instrument returns to the **PASSWORD** item in Maintenance Mode.
9. See “Entering Measuring Mode (START)” on page 102 to enter Measuring Mode.

Viewing the ROM/SUM (ROM/SUM)

The **ROM/SUM** screen shows the instrument’s firmware version and firmware checksum.

1. While in Maintenance Mode, press AIR to scroll to **ROM/SUM**.

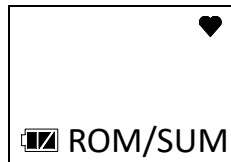

2. Press and release POWER MODE. The screen shows the ROM/SUM. The ROM is the top value and the SUM is the bottom value.

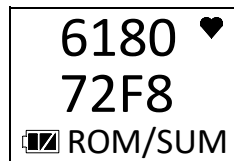

3. Press and release POWER MODE to return to the **ROM/SUM** item in Maintenance Mode.
4. See “Entering Measuring Mode (START)” on page 102 to enter Measuring Mode.

Performing a Default (M.DEF)

Performing a default operation in Maintenance Mode returns all parameters to their RKI factory settings.

1. While in Maintenance Mode, press AIR to scroll to **M.DEF**.



2. Press and release POWER MODE.

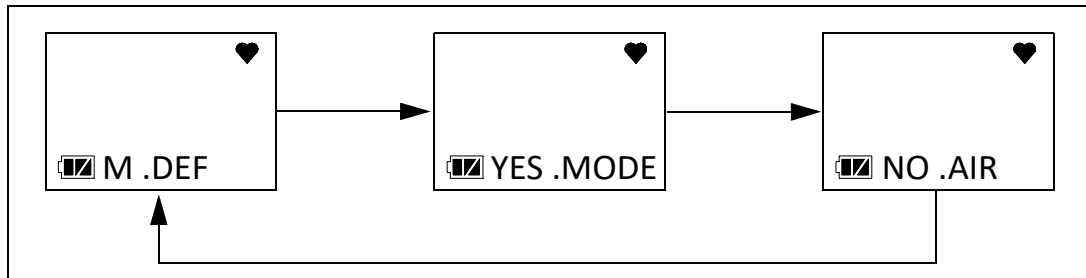

3. Press and release POWER MODE to perform a default operation. The instrument asks if you are sure you want to perform a default operation.

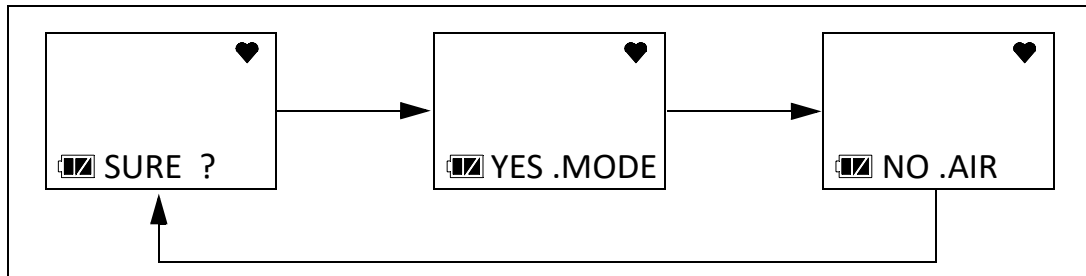

4. Press and release POWER MODE to perform a default operation. The instrument beeps twice and returns to the **M.DEF** item in Maintenance Mode.
5. See “Entering Measuring Mode (START)” on page 102 to enter Measuring Mode.

Entering Measuring Mode (START)

1. While in Maintenance Mode, press AIR to scroll to **START**.



2. Press and release POWER MODE. The instrument begins its warmup sequence.

Appendix B: Gas Select Mode

Overview

This appendix describes the CX-04 in Gas Select Mode. The CX-04 is factory-set to suit most applications. Update settings in Gas Select Mode only if required for your specific application. A description of the Gas Select Mode items is shown in Table 13 below.

Table 13: Gas Select Mode Menu Items

Menu Item (Page # of Description)	Description
SAVE-AP (page 104)	Set the current alarm points as the default alarm points.
MAX.SPAN (page 105)	<u>ON</u> : Maximum span screen appears after a successful calibration. <u>OFF (factory setting)</u> : No maximum span screen appears.
STEALTH (page 106)	<u>STEALTH ON</u> : No backlight, LED, or buzzer operation. <u>STEALTH OFF (factory setting)</u> : Backlight, LED, and buzzer operate normally.
	This setting has no effect unless STEALTH is set to ON. <u>VIB ON</u> : Vibrator activates for alarm conditions. <u>VIB OFF (factory setting)</u> : Vibrator does not activate in any situation.
START (page 106)	Enter Measuring Mode

Entering Gas Select Mode

WARNING: The CX-04 is not in operation as a gas detector while in Gas Select Mode.

1. Take the CX-04 to a non-hazardous location and turn it off if it is on.
2. Press and hold AIR, then press and hold POWER MODE. You will hear a beep after one second. Continue to hold the buttons down.
3. You will hear a second beep. Continue to hold the buttons down.
4. When you hear a third beep, release the buttons.
5. A password screen appears and the first digit flashes. The password is **2014**.

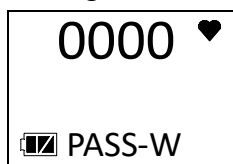

- Use AIR to select each password number then press POWER MODE to save it and move on to the next number. To go back a number, press and hold AIR and POWER MODE for a few seconds.
- The **SAVE-AP** item displays.



- Use AIR to move through the Gas Select Mode items.

Tips for Using Gas Select Mode

- To scroll from one item to the next, press and release AIR. To reverse the scrolling direction:
 - Press and hold AIR.
 - Immediately press POWER MODE and then release both buttons.
 - The scrolling direction returns to the original direction when you exit and reenter a menu.
- To skip an item when a question is asked, press and release AIR.
- To enter an item and to save any changes, press and release POWER MODE.
- To change a flashing parameter, press and release AIR. To reverse the direction of change (ie. from increasing to decreasing or vice versa):
 - Press and hold AIR.
 - Immediately press POWER MODE and then release both buttons.
- To exit an entered item without saving a change, press and hold AIR and POWER MODE for a few seconds.

Saving the Alarm Points (SAVE-AP)

Performing a **SAVE-AP** operation saves the current alarm setpoints.

Performing a **DEF.ALMP** operation in the **ALARM-P** User Mode menu sets the instrument's alarm points to those saved during the **SAVE-AP** operation (if performed).

Performing a **SAVE-AP** has no effect on an **M.DEF** in Maintenance Mode. An **M.DEF** operation returns all instrument settings to the RKI default regardless of if a **SAVE-AP** operation was performed.

- While in Gas Select Mode, press AIR to scroll to **SAVE-AP**.



2. Press and release POWER MODE. The display cycles through the following screens.

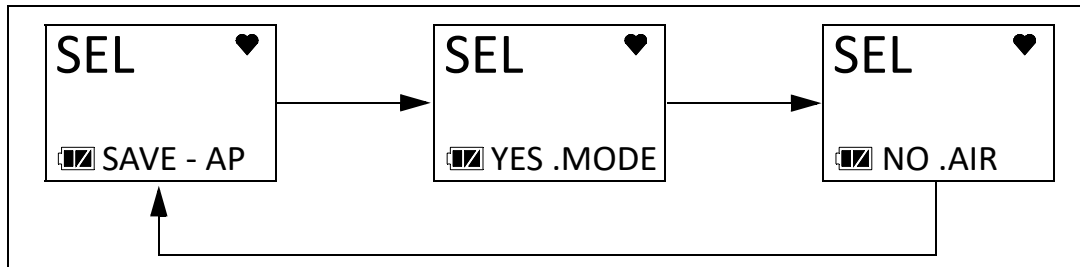

3. Press and release POWER MODE to save the current alarm point settings as the default.
4. The instrument returns to the **SAVE-AP** item in Gas Select Mode.
5. See “Exiting Gas Select Mode (START)” on page 106 to enter Measuring Mode.

Turning Calibration Max Span On/Off (MAX.SPAN)

ON: After a passed calibration, the CX-04 displays the response reading’s maximum adjustment. A maximum span of 100 ppm indicates that the reading could have been adjusted up to 100 ppm. If the maximum span value is close to the calibration value, the sensor should be replaced soon. The upper limit on the maximum adjustment indicated for the CO channel is either twice the calibration value or full scale, whichever is lower. The upper limit on the maximum adjustment indicated for the oxygen channel is 25.0% volume.

OFF (factory setting): There is no maximum span indication at the end of a calibration.

1. While in Gas Select Mode, press AIR to scroll to **MAX.SPAN**.



2. Press and release POWER MODE. The current setting flashes.
3. Use AIR to display the desired setting.
4. Press and release POWER MODE to save the setting and return to the **MAX.SPAN** item in Gas Select Mode.
5. See “Exiting Gas Select Mode (START)” on page 106 to enter Measuring Mode.

Stealth and Vibrator Settings (STEALTH)

STEALTH

ON:

- The instrument's backlight does not come on, regardless of the **BL TIME** setting.
- The instrument's LED does not come on for any reason, even alarm conditions.
- The instrument's buzzer does not sound for any reason, even alarm conditions.
- An "S" appears at the bottom of the LCD.

OFF (factory setting): The instrument's backlight, LED, and buzzer operate normally.

VIB

The **VIB** setting only affects instrument operation if **STEALTH** is set to **ON**.

ON: The vibrator activates for alarm conditions. It can be useful to have this feature turned on if you have also turned **STEALTH** on.

OFF (factory setting): The vibrator does not activate for any reason.

1. While in Gas Select Mode, press AIR to scroll to **STEALTH**.



2. Press and release POWER MODE. The current **STEALTH** setting flashes.
3. Use AIR to display the desired setting.
4. Press and release POWER MODE. The current **VIB** setting flashes.
5. Use AIR to display the desired setting.
6. Press and release POWER MODE to save the setting and return to the **STEALTH** item in Gas Select Mode.
7. See "Exiting Gas Select Mode (START)" on page 106 to enter Measuring Mode.

Exiting Gas Select Mode (START)

1. While in Gas Select Mode, press AIR to scroll to **START**.



2. Press and release POWER MODE. The instrument begins its warm-up sequence.

Warranty

RKI Instruments, Inc. warrants the CX-04 sold by us to be free from defects in materials, workmanship, and performance for a period of three years from the date of shipment from RKI Instruments, Inc. This includes the instrument and the original sensor. Replacement parts are warranted for 1 year from the date of their shipment from RKI Instruments, Inc. except for replacement sensors which are warranted for 3 years. Any parts found defective within their warranty period will be repaired or replaced, at our option, free of charge. This warranty does not apply to those items which by their nature are subject to deterioration or consumption in normal service, and which must be cleaned, repaired, or replaced on a routine basis. Examples of such items are:

- Absorbent cartridges
- Filter elements, disks, or sheets
- Pump diaphragms and valves

Warranty is voided by abuse including mechanical damage, alteration, rough handling, or repair procedures not in accordance with the instruction manual. This warranty indicates the full extent of our liability, and we are not responsible for removal or replacement costs, local repair costs, transportation costs, or contingent expenses incurred without our prior approval.

THIS WARRANTY IS EXPRESSLY IN LIEU OF ANY AND ALL OTHER WARRANTIES AND REPRESENTATIONS, EXPRESSED OR IMPLIED, AND ALL OTHER OBLIGATIONS OR LIABILITIES ON THE PART OF RKI INSTRUMENTS, INC. INCLUDING BUT NOT LIMITED TO THE WARRANTY OF MERCHANTABILITY OR FITNESS FOR A PARTICULAR PURPOSE. IN NO EVENT SHALL RKI INSTRUMENTS, INC. BE LIABLE FOR INDIRECT, INCIDENTAL, OR CONSEQUENTIAL LOSS OR DAMAGE OF ANY KIND CONNECTED WITH THE USE OF ITS PRODUCTS OR FAILURE OF ITS PRODUCTS TO FUNCTION OR OPERATE PROPERLY.

This warranty covers instruments and parts sold to users only by authorized distributors, dealers, and representatives as appointed by RKI Instruments, Inc.

We do not assume indemnification for any accident or damage caused by the operation of this gas monitor and our warranty is limited to replacement of parts or our complete goods.

CALL GEOTECH TODAY

(800) 833-7958

Geotech Environmental Equipment, Inc.

2650 East 40th Avenue • Denver, Colorado 80205

(303) 320-4764 • FAX (303) 322-7242

email: sales@geotechenv.com • website: www.geotechenv.com