

MultiRAE IR

MULTI-GAS MONITOR PGM-54

OPERATION AND MAINTENANCE MANUAL

(Document No.: 008-4028)

Rev.B



RAE SYSTEMS INC.
1339 Moffett Park Drive
Sunnyvale, CA 94089

December 2001



RAE Systems Product Line

- **Gas Detection Tubes & Pumps**
 - **SampleRAE Electronic Sampling Pump**
 - **MultiRAE PLUS Multi-gas Monitors**
 - **MultiRAE IR Multi-gas Monitors w/CO₂**
 - **MultiRAE Confined Space Monitor**
 - **QRAE PLUS Multi-gas Monitors**
 - **QRAE Confined Space Monitor**
 - **VRAE Five-Gas Monitors**
 - **DRAE Two-Gas Monitors**
 - **MiniRAE 2000 Portable VOC Monitor (PID)**
 - **ppbRAE Portable ppb-Level VOC Monitor (PID)**
 - **UltraRAE Specific Compound Monitor**
 - **CDRAE Corona Discharge VOC Monitor**
 - **ToxiRAE PLUS PID Monitor**
 - **ToxiRAE PLUS Single Gas Monitors**
 - **ToxiRAE PLUS Oxygen Monitor**
 - **ToxiRAE PLUS Combustible Gas Monitor**
 - **MiniRAE PLUS Classic PID**
 - **ModuRAE Fixed System PID**
 - **AreaRAE Wireless Multi-point, Multi-gas Systems**
-

How can I be informed and updated?

Be sure to mail in your warranty card via email, post or fax to get on RAE's private database (information is never supplied to others).

You will be updated on new products, technical advisory notices, new accessories and much more. Thank you for your purchase!

Table of Contents

1. GENERAL INFORMATION.....	1-1
1.1 General Specifications	1-2
2. OPERATION.....	2-1
2.1 Physical Description	2-2
2.2 Keys and Display	2-4
2.3 Power On/Off.....	2-7
2.4 Operation.....	2-10
2.5 Alarm Signals.....	2-17
2.6 Back Light.....	2-20
2.7 Preset Alarm Limits and Calibration	2-21
2.8 Integrated Sampling Pump.....	2-22
2.9 Datalogging.....	2-23
3. OPERATION OF ACCESSORIES.....	3-1
3.1 Battery Charging Operation.....	3-2
3.2 Alkaline Battery Adapter	3-4
3.3 Water Trap Filter.....	3-5
3.4 Remote Sampling Probe or Tygon Tubing	3-6
3.5 Dilution Fitting.....	3-7
3.6 Calibration Adapter.....	3-8
4. PROGRAMMING	4-1
4.1 Programming Mode	4-2
4.2 Keys for Programming Mode	4-4
4.3 Entering the Programming Menu.....	4-5
4.4 Calibration.....	4-7
4.4.1 Fresh Air Calibration.....	4-11
4.4.2 Multiple Sensor Calibration	4-12
4.4.3 Single Sensor Calibration.....	4-15
4.4.4 Modify Span Gas Value	4-19
4.4.5 Change LEL/VOC Span Gas	4-20
4.5 Change Alarm Limits.....	4-22
4.6 View or Change Datalog.....	4-24

4.6.1	Reset Peak and Minimum	4-25
4.6.2	Clear All Data.....	4-26
4.6.3	Change Datalog Period	4-27
4.6.4	Select Data Type	4-28
4.6.5	View Datalog.....	4-29
4.6.6	Enable / Disable Datalog.....	4-30
4.6.7	Select memory Full	4-30
4.7	Change Monitor Setup	4-31
4.7.1	Change Site ID	4-32
4.7.2	Change Alarm Mode	4-35
4.7.3	Change User Mode.....	4-36
4.7.4	Change Real Time Clock	4-37
4.7.5	Change Back Light Mode	4-38
4.7.6	Change Password	4-39
4.7.7	Change Pump Speed	4-40
4.7.8	Change Averaging Method	4-41
4.7.9	Change Language? & Set Temp. Unit? ..	4-41
4.8	Change Sensor Configuration	4-42
4.8.1	Change LEL/VOC Gas Selection	4-44
4.8.2	Enable / Disable Sensor	4-48
4.8.3	Change Dilution Ratio.....	4-49
4.8.4	Change PID Lamp Type.....	4-50
4.9	Exit Programming Mode.....	4-51
5.	COMPUTER INTERFACE.....	5-1
5.1	ProRAE-Suite Software Installation	5-2
5.2	PC Connection	5-4
5.3	Starting ProRAE-Suite Software	5-5
5.4	Setup of Communication Port.....	5-7
5.5	Processing the Configuration Data	5-8
5.5.1	Editing the Configuration Data	5-9
5.5.2	Sending Configuration to Monitor.....	5-20
5.5.3	Saving Configuration Data.....	5-21

6. THEORY OF OPERATION	6-23
7. MAINTENANCE	7-1
7.1 Battery Replacement	7-2
7.2 Sensor Replacement	7-4
7.3 Sensor Cleaning/Replacement	7-7
7.4 PID Lamp Care	7-9
7.5 Sampling Pump Replacement	7-11
8. TROUBLESHOOTING	8-1
8.1 Special Diagnostic Mode	8-2
8.2 Troubleshooting Table	8-10
APPENDIX A. QUICK REFERENCE GUIDE	A-1
APPENDIX B. CORRECTION FACTORS	B-1
APPENDIX C. MULTIRAE DATA	
CONVERSION TO MICROSOFT EXCEL®	C-1
APPENDIX D. TECHNICAL NOTES	D-1
APPENDIX E. APPLICATION NOTES	E-1
APPENDIX F. LITERATURE REQUEST	F-1
APPENDIX G. REQUEST FORM FOR RMA	G-1
Main Contact Numbers	Outside Back Cover



- DO NOT proceed before reading -

This manual must be carefully read by all individuals who have or will have the responsibility for using, maintaining, or servicing this product.

The product will perform as designed only if it is used, maintained, and serviced in accordance with the manufacturer's instructions.

CAUTION!!

To reduce the risk of electric shock, turn off power before removing the monitor cover. Disconnect the battery before removing sensor module for service. Never operate the monitor while the cover is removed. Remove monitor cover and sensor module only in an area known to be non-hazardous.

Special Notes

-1-

When the PGM-54 Multi-Gas Monitor is taken out from the transport case and turned on for the first time, there may be some residual organic or inorganic vapor trapped inside the detector chamber. The initial PID or toxic sensor reading may indicate a few ppm. Place in an area free of organic or toxic vapor and turn on the monitor. After running for several minutes, the residual vapor in the detector chamber will be cleared and the reading should return to zero.

-2-

The battery of the MultiRAE IR monitor will discharge slowly even if it is turned off. If the monitor has not been charged for 5-7 days, the battery voltage will be low. Therefore, it is a good practice to always charge the monitor before using it. It is also recommended to fully charge the monitor for AT LEAST 10 HOURS before initial use (see Section 7.1 for more information on battery replacement and charging).

-3-

For uninstalled PID lamp/sensor, this instrument must be kept with a PID sensor “disabled”. Enabled PID sensors may cause a lamp alarm, when there is no lamp installed.

WARNINGS:

Use only RAE Systems battery packs, for the specific instrument PGM-54. This instrument has not been tested in an explosive gas/air atmosphere. Operate the instrument and recharge batteries only in non-hazardous locations.

AVERTISSEMENT:

Utiliser seulement l'ensemble de batterie RAE Systems, pour l'instrument PGM-54 spécifique. Cet instrument n'a pas été essayé dans une atmosphère de gaz/air explosive. Ne charger les batteries que dans l'emplacements désignés non-dangereux.

STATIC HAZARD:

Clean only with a damp cloth.

**DANGER RISQUE D'ORIGINE
ELECTROSTATIQUE:**

Nettoyer uniquement avec un chiffon humide.

CAUTION:

For safety reasons this equipment must be operated and serviced by qualified personnel only. Read and understand instruction manual completely before operating or servicing.

ATTENTION:

Pour des raisons de sécurité, cet équipement doit être utilisé, entretenu et réparé uniquement par un personnel qualifié. Étudier le manuel d'instructions en entier avant d'utiliser, d'entretenir ou de réparer l'équipement.

CAUTION:

Before each day's usage, sensitivity must be tested on a known concentration of methane gas equivalent to 20-50% of full-scale concentration. Accuracy must be within -0-+20% of actual. Accuracy may be corrected by calibration procedure.

ATTENTION:

Avant chaque utilisation journalière vérifier la sensibilité avec une concentration connue de méthane équivalente à 20 - 50% de la pleine échelle. La précision doit être comprise entre 0 - 20% de la valeur vraie et peut être corrigée par une procédure de recalibrage.

CAUTION:

Any rapid up-scale reading followed by a declining or erratic reading may indicate a gas concentration beyond upper scale limit which may be hazardous.

ATTENTION:

Toute lecture rapide et positive, suivie d'une baisse subite au erratique de la valeur, peut indiquer une concentration de gaz hors gamme de détection qui peut être dangereuse.

CALIBRATION WARNINGS:

The calibration of all newly purchased RAE Systems instruments should be tested by exposing the sensor(s) to known concentration calibration gas(es) before the instrument is put into service for the first time.

For maximum safety, the accuracy of the MultiRAE IR should be checked by exposing the sensor(s) to known concentration calibration gas(es) before each day's use.

AVERTISSEMENT:

La calibration de toute instruments de RAE Systems doivent être testé en exposant l'instrument a une concentration de gaz connue par une procédure diétalonnage avant de mettre en service l'instrument pour la première fois.

Pour une sécurité maximale, la sensibilité du MultiRAE IR doit être verifier en exposant l'instrument a une concentration de gaz connue par une procédure diétalonnage avant chaque utilisation journalière.

1. GENERAL INFORMATION

The MultiRAE IR is a programmable multi-gas monitor designed to provide continuous exposure monitoring of carbon dioxide, toxic gases, oxygen and combustible gases for workers in potentially hazardous environments. It uses the following sensors:

- (1) Organic vapors with the supplied Photo-Ionization Detector (PID) using 9.8 eV, 10.6 eV or 11.7 eV gas discharge lamp;
- (2) Carbon dioxide with a miniaturized Non-Dispersive Infrared (NDIR) sensor;
- (3) One toxic gas with one of several interchangeable electrochemical sensors;
- (4) Oxygen with an electrochemical sensor; and
- (5) Combustible gases with a catalytic bead sensor.

Other features include:

- **Lightweight and Compact**
 - 16 oz (454 g), hand-held size.
- **Dependable and Accurate**
 - 12 hours monitoring with micro controller.
- **User Friendly**
 - menu driven, intuitive end-use operation.
- **Programmable Alarm Thresholds**
 - audio buzzer & flashing display alarm.

The MultiRAE IR (PGM-54) kit consists of: A multi-gas monitor, battery charger, rubber boot, alkaline battery adapter, water and dust filters, plus calibration accessories.

1.1 General Specifications

Table 1.1 **Multi-Gas Monitor Specification**

Dimensions:	4.65”L x 3.0”W x 1.9”H (11.8 cm x 7.6 cm x 4.8 cm)
Weight:	16 oz (454 g) with battery.
Detector:	Up to five sensors (carbon dioxide, oxygen, combustible, one toxic and VOC), a non-dispersive infrared sensor for carbon dioxide, electrochemical sensors for toxic gases and oxygen, a photo-ionization sensor for VOC, a catalytic sensor for combustible gases.
Battery:	Rechargeable, Li-ion battery pack with built-in charger (12 hours charge time) or a 4 AA alkaline battery adapter.
Operating Time:	12 hours continuous operation.
Display:	2 line, 16 digit LCD with LED back light automatically in dim light.
Key-pads:	1 operation key and 2 programming keys.
Direct Readout:	Instantaneous values (up to 5), sensor name, high and low values for all detectors, TWA and STEL values for CO ₂ , toxic and VOCs, battery voltage and elapsed time.

Multi-Gas Monitor Specification (continued)

Alarm Settings: Separate alarm limit settings for TWA, STEL, Low and High alarm.

Range, Resolution and Response Time (t_{90}):

CO ₂	0-20000 ppm	10 ppm	60 sec
O ₂	0-30 %	0.1 %	15 sec
VOC	0-200 ppm	0.1 ppm	10 sec
VOC	200-2000 ppm	1 ppm	10 sec
LEL	0-100 %	1 %	15 sec
CO	0-500 ppm	1 ppm	20 sec
H ₂ S	0-100 ppm	1 ppm	30 sec
SO ₂	0-20 ppm	0.1 ppm	15 sec
NO	0-250 ppm	1 ppm	20 sec
NO ₂	0-20 ppm	0.1 ppm	25 sec
Cl ₂	0-10 ppm	0.1 ppm	60 sec
HCN	0-100 ppm	1 ppm	60 sec
NH ₃	0-50 ppm	1 ppm	150 sec
PH ₃	0-5 ppm	0.1 ppm	60 sec

NOTE: t_{90} values for most electrochemical sensors are based on vendors' specification. Actual monitor responses may be longer depending on measuring conditions.

Alarm: 90 dB buzzer and flashing red LED to indicate exceeded preset limits, low battery, or sensor failure.

Calibration: Two point field calibration for fresh air and standard reference gas.

Attachment: Rubber boot, wrist strap, belt clip.

Sampling Pump: Internal integrated with 150 cc/min flow rate (high setting).

Protection: Password protected calibration settings, alarm limits, and data.

Multi-Gas Monitor Specification (continued)

EM Immunity:	No effect when exposed to 0.43 mW/cm ² RF interference (5 watt transmitter at 12 inches).
Data Storage:	20,000 readings (64 hours, 5 channels at 1 minute interval) in non-volatile memory.
Datalog Interval:	Programmable 1- 3600 sec.
External Alarm:	Optional plug in pen size vibration alarm or earphone.
Communication:	Upload data to PC and Download monitor setup from PC through RS-232 link to serial port on PC.
Temperature:	-20° to 45°C (-4° to 113° F).
Humidity:	0 % to 95% relative humidity. (non-condensing)
Housing:	ABS + PC, splash and dust proof
Configuration:	1, 2, 3, 4 and 5 gas with pump and with or without datalogging.

2. OPERATION

The MultiRAE IR monitor gives real time measurements and activates alarm signals whenever the exposure exceeds preset limits. Prior to factory shipment, the MultiRAE IR is preset with default alarm limits and the sensors are pre-calibrated with standard calibration gas. However, the user should calibrate the instrument before the first use. After the monitor is fully charged and calibrated, it is ready for immediate operation.

2.1 Physical Description

Figure 2-1 shows the main components of the MultiRAE IR Multi-Gas Monitor which include:

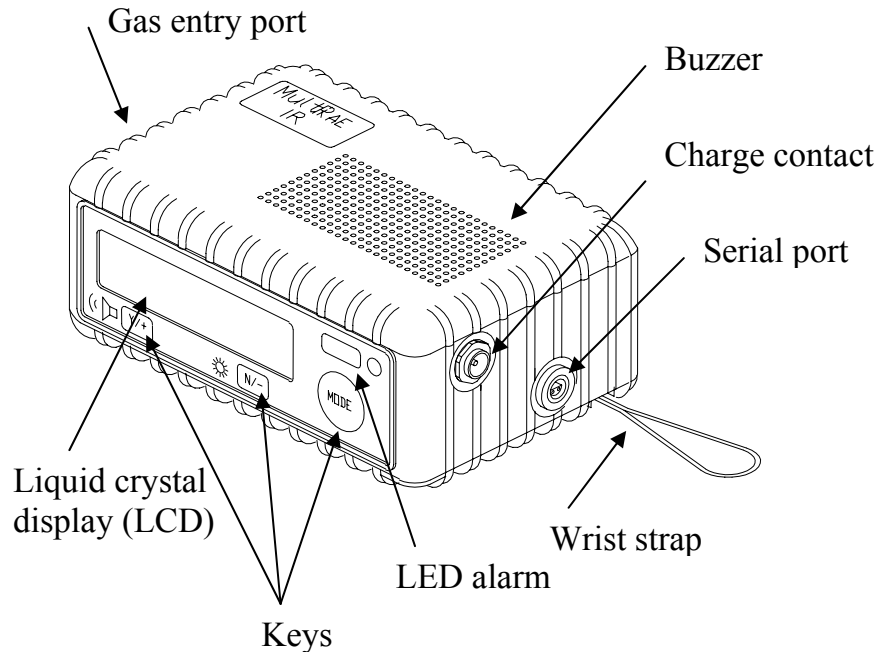

Figure 2-1 Major parts of the MultiRAE IR Multi-Gas Monitor

- 3 keys for the user to interact with the monitor: 1 operation key and 2 programming keys for normal operation or programming of the monitor.
- LCD display with back light to show real time and calculated measurements.

OPERATION

- Buzzer and red LED for alarm signal whenever the exposures exceed preset limits.
- Wrist strap.
- Charge contact for plugging directly to the charging station.
- Gas entry port.
- Serial communication port for PC interface.

2.2 Keys and Display

Figure 2-2 shows the LCD display and the keypad on the front panel of the monitor. The functions of the 3 keys during normal operation are summarized in Table 2.1 on the next page:

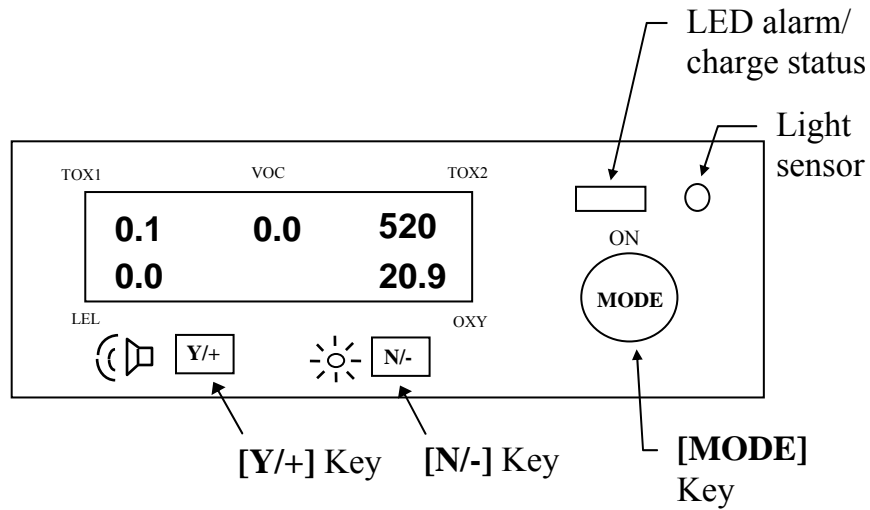

Figure 2-2 Key-pad and Display of the MultiRAE IR Multi-Gas Monitor

Table 2.1

Key	Function in Normal Operation
[MODE]	Turn on/off the power* and choose different display mode.
[N/-]	Toggle on/off the back light. Answer as “No.”
[Y/+]	Alarm test and alarm acknowledgment (turn off latched alarm, turn on pump or LEL sensor). Answer as “Yes.”

* Pressing and holding [MODE] for 5 seconds turns off the power to the monitor. The monitor will beep once per second during the power-down sequence. Press [MODE] momentarily to choose different display modes (see Section 2.4 for details).

The Multi-Gas Monitor includes a 2-line, 16-digit dot matrix liquid crystal display (LCD). The LCD shows the following eight types of displays during normal operation if the [MODE] key is pressed:

- Real time instantaneous gas concentration in ppm for CO₂, toxic and VOC gases, % by volume for oxygen and % LEL for combustible gases.
- Sensor names.
- Peak and minimum gas concentration for CO₂, toxic, VOC, oxygen and combustible gases.
- 15 minute Short Term Exposure Level (STEL) values of the CO₂, toxic and VOC gases in ppm and 8 hours Time Weighted Average (TWA).
- Battery voltage and shut off voltage in volts.
- Real time clock, run time and temperature.
- Datalogging mode or “Start / Stop Datalog?” menu to enable/disable datalogging if manual datalogging mode is selected.
- LEL or VOC gas names (if the LEL and VOC sensor are installed).
- “Print Reading?” menu to print the reading to the RAE Printer.
- “Communicate with PC?” menu to send or receive data between PC and the MultiRAE IR monitor.

2.3 Power On/Off

To turn on the MultiRAE IR Multi-Gas Monitor, press the [MODE] key. The audio buzzer will beep once and the display will show “ON!..” and then “MultiGas Monitor Ver n.nn” to indicate the software version number. The customer, using the ProRAE Suite Software can change the power-on-name. The model number, serial number, current date and time, temperature of the monitor are displayed next. The monitor will then go through each sensor socket to check if a valid sensor is installed. If a new sensor is installed, a message to remind the user to calibrate the sensor will be displayed followed by a message that the alarm limits have been reset to the default values for the new sensor. If a sensor reaches its expected end of life, a “Warranty Expired” message will be displayed.

Next, the monitor displays the preset alarm limits for each sensor, battery voltage, shut off voltage, user mode, alarm mode, datalog mode, available data storage memory (in hours), datalog mode and datalog interval (in seconds). Then after a set delay time of several seconds, the display shows the instantaneous reading of the gas concentrations and is ready to monitor gases.

To turn off the MultiRAE IR Multi-Gas Monitor, press and hold the [MODE] key for 5 seconds. Monitor will beep once per second during power-down sequence with a count down timer showing the number of remaining seconds. The message “Off!..” flashes on the LCD display

and the display will go blank, indicating that the monitor is turned off.

Turning off the Multi-Gas monitor with the AC charger in place will result in a display of “Charging..” or “Battery Charged” and indication of battery voltage. This indicates that the monitor is off, but the smart charger circuit is now active.

To turn the unit on from the charge or discharge mode, press the [MODE] key.

Data protection during power off

When the monitor is turned off, all the current real time data including TWA, STEL, Peak and elapsed time are erased. However, the datalog data is preserved in non-volatile memory. Even if the battery is disconnected, the datalog data will not be lost. During the power off period, the real time clock will continue to operate until the battery is completely drained (usually in 5-7 days without any charging). If the battery is completely drained or is disconnected from the monitor for more than 30 minutes, the real time clock will be lost. In this case, users need to enter the real time clock information again, as described in Section 4.

Datalog versus Non Datalog monitor

There are two versions of the PGM-54 Multi-Gas Monitors: Datalog monitors and Non-Datalog monitors. During power on sequence, a letter “D” following the version number indicates that the monitor is configured as a Datalog monitor. Without the letter “D”, it is a Non-Datalog monitor.

Users can upgrade a Non-Datalog monitor to a Datalog monitor. Call the factory for information on how to order the upgrade kit.

2.4 Operation

The MultiRAE IR Multi-Gas Monitor offers three different user modes of operation:

Text mode,
Display mode, and
Programming mode (default mode setting).

The **text** mode is the simplest mode of operation. The monitor will display the sensor name after the monitor is turned on. The user can press the **[MODE]** key to see the instantaneous gas concentration reading, battery voltage or enter the PC communication menu. The user can get into the calibration mode from text mode to do calibrations, but cannot change most of the parameters.

In the **display** mode, the MultiRAE IR Multi-Gas Monitor is able to display all the information in the text mode. In addition, the following information is also available by pressing the **[MODE]** key: peak, minimum, STEL, TWA, run time in hours and minutes, temperature in degree C, datalog mode (or enable / disable datalogging operation in manual datalog mode), LEL/VOC gas names, printing and communication with a PC options. The user cannot get into the calibration mode from display mode, so the user cannot do calibration and cannot change any of the parameters.

In the **programming** mode, which is the default setting, the user can perform all of the functions of the display mode. In addition, the user can get into calibration mode,

perform calibrations and change any of the parameter in the calibration mode.

The following is the detail explanation of the displays when the [MODE] key is pressed

- 1) The **instantaneous** reading is the actual gas concentration in parts per million (ppm) for CO₂, toxic or VOC gases, % of volume for oxygen and % of LEL for combustible gases. The reading is updated once per second and is shown in the LCD display.

TOX1	VOC	TOX2
0	0.0	520
0		20.9
LEL		OXY

- 2) The **sensor names** are displayed as:
 - CO, H₂S, etc.: for a toxic gas sensors
 - VOC: for PID sensor
 - CO₂: for carbon dioxide sensor
 - LEL: for combustible gas sensor
 - O₂: for oxygen sensor

TOX1	VOC	TOX2
CO	VOC	CO2
LEL		OXY
LEL		OXY

- 3) The **Peak** reading is the highest reading of each gas concentration since the monitor was turned on. The reading is updated at one second intervals and is shown in the LCD display with “Peak” message.

TOX1	VOC	TOX2
5	2.0	
	1630	
10	Peak	20.9
LEL		OXY

- 4) The **Minimum** reading is the lowest reading of each gas concentration since the monitor was turned on. The reading is updated at one second intervals and is shown in the LCD display with “Min” message.

TOX1	VOC	TOX2
0	0.0	
350		
0	Min	19.9
LEL		OXY

- 5) The **STEL** reading is the last 15 minute average reading of the gas concentration. The reading is updated once per minute and is shown in the LCD display with “STEL” message. For the first 15 minutes, “****” will be displayed. This reading applies to toxic, VOC and CO₂ gases only.

TOX1	VOC	TOX2
0	0.0	0
	STEL	
LEL		OXY

6) The **TWA** reading is the accumulated reading of the gas concentration divided by 8 hours since the monitor was turned on. The reading is updated once a minute and is shown in the LCD display with “TWA” message. This reading applies to toxic, VOC and CO₂ gases only.

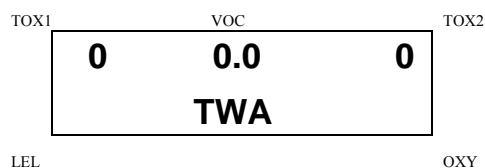

7) The **battery voltage** reading is the current battery voltage in volts. The reading is updated once per second and is shown in the LCD display. The shut down voltage is also shown. Note: A fully charged battery pack should show 4.6 volts or higher. When the battery voltage falls below 4.4 volts, a flashing “Bat” will appear as a warning message. This means there is about 15 minutes run time left before the monitor will be turned off automatically, when the battery voltage falls below 4.3 volts. Alkaline batteries may behavior differently.

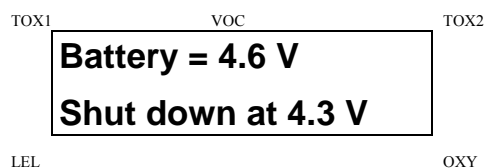

- 8) The **run time** reading is the accumulated “On” time in hours and minutes since the monitor was turned on. The reading is updated at one-minute intervals and is shown in the LCD display together with the current date, time and temperature.

TOX1	VOC	TOX2
8/3/01		8:30
On = 03:50		20°C
LEL		OXY

- 9) The **datalog** menu shows the current datalog mode. If manual datalog mode is selected, the menu will prompt the user to turn on or off datalogging. Pressing the [Y/+] key while “Start Datalog?” message is displayed turns on the datalogging. Likewise, pressing the [Y/+] key while “Stop Datalog?” message is displayed turns off the datalogging.
- 10) The monitor will display the selected **LEL** and **VOC gas name** if the combustible sensor and PID sensor are installed. When an LEL or VOC gas is selected, the “calculated” gas concentration based on the built-in correction factor for that specific gas will be displayed.
- 11) **Print Reading?** asks for printing out of the gas concentration reading. If a serial printer is connected and ready, press the [Y/+] key will print out the reading.

12) The **Communicate with PC?** menu display allows the user to upload data from the MultiRAE IR to a Personal Computer (PC) or download configuration information from a PC to the MultiRAE IR. Press the [Y/+] key and the LCD displays the message “Monitor will pause, OK?” to remind the users that during PC communication, there will be no real time monitoring of the gas concentration. Press [Y/+] key to proceed and the monitor enters the communication standby mode. The LCD then displays “Ready...” Connect the monitor to the serial port of a PC. The monitor is then ready to receive any command from the PC.

Note: When the monitor is in communication standby mode, it stops monitoring the gas concentration and stops datalogging. It takes 60 sec. to return to the instantaneous reading. Datalogging must be manually restarted when exiting the communication standby mode, unless it is in automatic datalogging mode.

Displays in text mode:

The four displays are arranged in a “round robin” order:

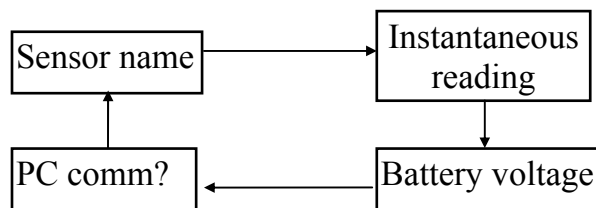

Displays in display or program mode:

The twelve displays are arranged in a “round robin” order:

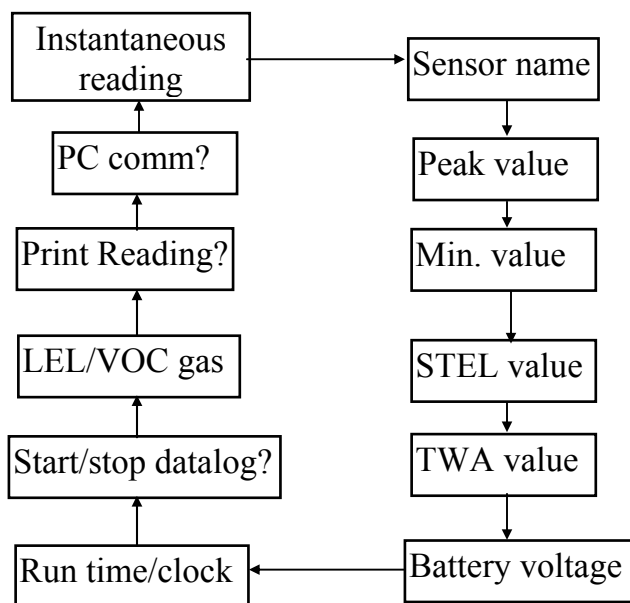

To choose a specific display, press the **[MODE]** key one or more times until the desired display appears.

Display time out

In all displays, the LCD will automatically return to the instantaneous reading (in display or program mode) or sensor name (in text mode) after a one-minute time out interval if no key is pressed.

2.5 Alarm Signals

The built-in microcomputer constantly updates and monitors gas concentration and compares it with the programmed alarm limits (TWA, STEL, and two instantaneous gas concentration alarm limit settings: Low & High). Whenever the concentration exceeds any of the preset limits, the loud buzzer and red flashing LED are activated immediately to warn the user of the alarm condition.

In addition, the MultiRAE IR will alarm if one of the following condition occurs: battery voltage falls below a pre-set voltage level (4.3 V), failure of UV lamp, LEL sensor off, pump stall or when the datalog memory is full. When the low battery alarm occurs, there will be approximately 15 minutes of operating time remaining. When the battery voltage falls below 4.3 V, the monitor will be turned off automatically.

Alarm Signal Disabled: It is extremely important to note that during the following conditions, the alarm signals are disabled:

- 1) In PC communication standby mode.**
- 2) In calibration mode (including reviewing datalog data).**

During these modes of operation, real time monitoring of the gas concentration stops. None of the gas concentrations will be calculated, including Peak, STEL and TWA.

Alarm Signal Latching:

It is possible to setup the MultiRAE IR from a PC or in programming mode so that when an alarm condition occurs, the alarm signals stay on even after the alarm condition is no longer present. This is called the “latching alarm” mode. The alternative mode is to automatically reset the alarm signal when the alarm condition is cleared. The default alarm mode is automatic reset

Alarm Signal Summary:

The various alarm signals are summarized here:

Condition	Alarm Signal
Gas exceeds “High Alarm” limit	3 beeps/flashes per second plus sensor name on LCD
Gas exceeds “Low Alarm” limit	2 beeps/flashes per second plus sensor name on LCD
Gas exceeds STEL	1 beep/flash per second plus sensor name on LCD
Gas exceeds TWA	1 beep/flash per second plus sensor name on LCD
Negative Drift or Over Range	3 beeps/flashes per second plus NEG or OVR name on LCD
Pump failure	3 beeps/flash per second plus “Pump” message on LCD
LEL sensor off	3 beeps/flash per second plus LEL sensor name and “Off” message on LCD

PID lamp failure	3 beeps/flash per second plus “Lamp” message on LCD
Low battery	1 flash per second, 1 beep per minute plus “Bat” message on LCD
Memory full	1 flash per second plus “Mem” message on LCD

Alarm Signal Testing:

Under normal non-alarm conditions, it is possible to test the MultiRAE IR LED, buzzer and back light by pressing the [Y/+] key momentarily. The buzzer will beep once and the LED and back light will flash once to indicate that these alarm signals are functioning correctly.

WARNING:

The alarm signals are disabled during PC communication, calibration or datalog review operation. To reduce the risk of exposure to hazardous atmospheres, perform PC communication, calibration or datalog review only in area known to be non-hazardous.

2.6 Back Light

The LCD display is equipped with an LED back light to assist in reading the display under poor lighting conditions. This back light can be turned on **manually** by pressing and holding the [N/-] key for one second in normal operation. The back light can be turned off by pressing [N/-] a second time. If the [N/-] key is not pressed, the back light will be turned off automatically after a pre-programmed time-out period to save power.

In automatic mode, the ambient light is sensed and the back light will be turned on **automatically** if the ambient light is below a threshold level. The back light will be turned off automatically when the ambient light exceeds the threshold level.

(See Chapter 4.7 for details on how to set back light mode and time out period from the monitor or from PC.)

Note: The LED back light consumes a higher amount of energy from the battery and shortens the operating time of the monitor by 20 - 30%.

2.7 Preset Alarm Limits and Calibration

The MultiRAE IR Multi-Gas Monitor is factory calibrated with standard calibration gas, and is programmed with default alarm limits as listed below. (refer to Section 4 for programming procedures if new calibration or alarm limits is required).

Table 2.2

Factory Calibration and Preset Alarm Limits						
Gas ppm	Cal Gas / Balance	Unit	TWA	STEL	Low	High
O ₂	20.9 / N ₂	%Vol	-	-	19.5	23.5
CH ₄	50 / Air	%LEL	-	-	10	20
CO ₂	5000 / N ₂	ppm	5000	8000	5000	5000
VOC*	100 / Air	ppm	10.0	25.0	50.0	100
CO	50 / Air	ppm	35	100	35	200
H ₂ S	25 / N ₂	ppm	10	15	10	20
SO ₂	5 / N ₂	ppm	2	5	2	10
NO	25 / N ₂	ppm	25	25	25	50
NO ₂	5 / Air	ppm	1	1	1	10
Cl ₂	10 / N ₂	ppm	0.5	1	0.5	5
HCN	10 / N ₂	ppm	5	5	5	50
NH ₃	50 / N ₂	ppm	25	35	25	50
PH ₃	5 / N ₂	ppm	0.3	1	1	2

***Note:** 100 ppm isobutylene gas is used for VOC gas calibration, and can also be used for zero calibration of CO₂ sensor.

2.8 Integrated Sampling Pump

The MultiRAE IR Monitor includes an integrated sampling pump. This is a diaphragm pump providing about 300 cc per minute flow rate at the high setting. A low pump speed of about 200 cc per minute is the factory default setting, which will increase the battery life by about 5% and give an increased LEL sensor lifetime.

The high pump speed setting is recommended for vapors that are especially reactive or adsorb easily to instrument surfaces. Such vapors include Cl_2 , PH_3 , NH_3 , HCN , and semi-volatile organic compounds like diesel fuel and jet fuels. For such compounds it is also desirable to use inert connecting and sampling tubing, such as Teflon instead of Tygon, and to make connections as short as possible. It may also be helpful to remove the water trap filter (see Section 3.3 for precautions). The pump is turned on automatically when the monitor is turned on and remains on during normal operation.

If liquid or other objects are sucked into the water trap in the inlet port and cause the pump to stall, the monitor will detect the obstruction and shut down the pump immediately. The alarm will be activated and a flashing error message “Pump” will be also displayed in the LCD display. After clearing the obstruction, press the [Y/+] key to acknowledge the pump shut off condition and re-start the pump. Different pump shut-off thresholds are desired for the two pump settings; this value can be adjusted in the Special Diagnostic Mode as described in Section 8.1.

2.9 Datalogging

The MultiRAE IR Multi-Gas Monitor calculates and stores the gas readings based on a user-specified datalogging period and the type of measurement. Two types of gas measurements, average or peak concentration can be stored for each sensor during each datalogging interval. The datalogging interval can be programmed from one second to 60 minutes in one-second increments. In addition, time stamp, user ID, site ID, serial number, last calibration date, and alarm limits are also stored. All data is retained in a non-volatile memory so that it can be down loaded at a later time to a PC.

Datalog Options

There are four ways to initiate the datalog operation:

- **Automatic:** Start and stop datalogging automatically when the monitor is turned on and off.
- **Manual:** Start and stop datalogging by pressing a key manually. There is a timer available to setup the maximum datalogging time.
- **Periodic:** Start and stop datalogging daily based on preset time (hour and minute).
- **Schedule:** Start and stop datalogging based on preset date and time (month, date, hour and minute).

Choose a datalog option

Most of the datalogging options can be programmed from the monitor. Additional options can be programmed using a PC and down loaded to the monitor (see Chapter 5 for details on how to program various datalogging options).

Start/stop datalogging manually

If manual datalogging mode has been selected from the normal operation menu, toggle through the menu using the [MODE] key until the **Start Datalog?** prompt is displayed. Pressing the [Y/+] key turns on datalogging. Likewise, pressing the [Y/+] key while **Stop Datalog?** is displayed, turns off datalogging.

The other three datalogging options will start and stop automatically without any user intervention:

Datalogging event

Each time a datalogging operation is initiated, a datalog event is created. Information, such as start time, datalogging period, alarm limits, etc. will be recorded in the event header, followed by the measurement data. If more than 900 measurement intervals are recorded in one event, a new event will be created automatically.

Datalogging pause

Under the following conditions, the datalogging will be paused automatically:

- 1) When entering programming mode, datalogging will stop. Upon exiting the programming mode, the datalogging will resume.
- 2) When entering PC Communication standby mode, datalogging will stop. Upon exiting the PC communication standby mode, datalogging will resume **only if datalogging mode was set to automatic mode.**

In either case, a new datalog event will be created when the datalogging is resumed.

3. OPERATION OF ACCESSORIES

The accessories for MultiRAE IR include:

- Battery charger
- Alkaline battery adapter
- Water trap filter and remote sampling probe
- Dilution fitting
- Calibration adapter

WARNING:

To reduce the risk of ignition of hazardous atmospheres, recharge battery only in area known to be non hazardous. Remove and replace battery only in area known to be non hazardous.

Ne charger les batteries que dans l'emplacements désignés non-dangereux.

3.1 Battery Charging Operation

The charging circuit of the MultiRAE IR is built into the monitor. It only needs a regular AC to 12V DC adapter (wall mount transformer) to charge the monitor.

1. Connect the AC adapter (or the optional automotive charging adapter) to the DC jack on the MultiRAE IR monitor.

2. The display will ask whether a discharge cycle (see NOTE on next page) is required, press [N/-], and the charging function will begin. The display will show "Charging.....". If a key is not pressed within ten seconds, the charging will begin automatically.

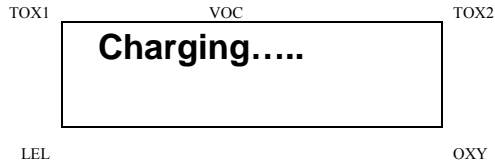

3. The LED should be red in color when charging. If the battery is fully charged, the LED will change from red to green. The red color indicates that the battery is being charged. The green color indicates that the battery is fully charged. The display will also indicate "Fully charged." A completely discharged MultiRAE IR monitor will be charged to full capacity within about 10 hours.

Note 1: The MultiRAE IR monitor has a smart charging circuitry and algorithm to prevent overcharging and damage when left on the charger for extended periods.

Note 2: The NiCd rechargeable batteries used in the MultiRAE PLUS cannot be used in the MultiRAE IR.

The MultiRAE IR battery will be drained slowly even if the monitor is turned off. If the monitor has not been charged for 5-7 days, the battery voltage will be low.

The factory supplied battery is designed to last for 12 hours of normal operation (no alarm, no back light condition) for a new battery under the best condition. As the battery becomes older or is subject to adverse conditions (such as cold ambient temperature), the battery capacity may be reduced significantly.

3.2 Alkaline Battery Adapter

An alkaline battery adapter is supplied with each MultiRAE IR kit. It accepts four AA size alkaline batteries and can be used in place of the Li-ion battery pack to provide approximately 8 hours of operation depending the battery quality. The adapter is intended to be used in emergency situations when there is no time to charge the Li-ion battery

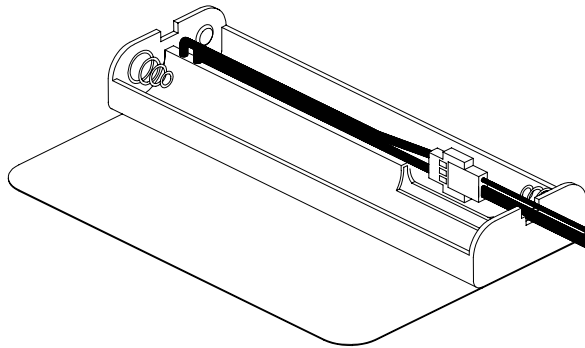

Figure 3-1 Alkaline Battery Adapter

To install the adapter, remove the cover of the monitor. Unplug the Li-ion battery pack from the battery connector and plug the alkaline battery adapter into the battery connector.

The internal charging circuit will automatically detect the alkaline battery adapter and prevent charging of the battery.

3.3 Water Trap Filter

The water trap filter is made of PTFE (Teflon[®]) membrane with a 0.2 micron pore size to prevent liquid water from being sucked into the sensor manifold, which would cause extensive damage to the monitor. It will also prevent any dust from entering the monitor and will prolong the operating life of the sensors.

To install the water trap filter, simply slide the Tygon tubing onto the ribbed inlet port on the monitor. A male Luer connector fits to the female Luer of the filter. To remove the filter, disconnect the Luer connector.

The water filter may slow the response to vapors that are especially reactive or adsorb easily to surfaces. Such vapors include Cl₂, PH₃, NH₃, HCN, and semi-volatile organic compounds like diesel fuel and jet fuels. For these compounds the high pump speed setting should be used (see Section 2.8). It is also desirable to use inert connecting and sampling tubing, such as Teflon instead of Tygon, and to make connections as short as possible. The unit may be operated without the filter to shorten the response time, but in this case the pump warranty will be voided and the pump stall feature will not protect the unit from inadvertent suction of liquids.

3.4 Remote Sampling Probes

An optional 6-foot Teflon remote sampling probe with a telescoping handle or a 15-foot Tygon tubing are handy accessories for users to probe areas that are difficult to reach, such as ceilings, storage tanks, underground man-holes, etc. Connect the male Luer connector at the end of the remote sampling probe or the Tygon tubing to the female Luer connector on the water trap filter. The remote sampling probe or tubing is ready for operation.

Teflon remote sampling tubing should be used for reactive gases such as Cl_2 , PH_3 , NH_3 , HCN , and for semi-volatile organic compounds like gasoline and jet fuels. A few feet of Tygon tubing can completely absorb a kerosene-type fuel. Tygon can be used for the common confined space entry gases including CO , H_2S , and CH_4 .

3.5 Dilution Fitting

An optional dilution fitting can be installed together with the remote sampling probe or Tygon tubing on the gas inlet port to dilute the gas samples. This fitting is needed if the gas sample does not contain more than 10% of oxygen. This is due to the fact that the combustible sensor will not function correctly when the oxygen concentration falls below 10%. The dilution fitting will increase the oxygen concentration so that the combustible sensor can still be used under oxygen deficiency conditions. The other use of the dilution fitting is to measure the combustible, VOC or toxic gas when the concentration exceeds the upper limit of the sensor range.

To use the dilution fitting, insert the fitting between the water trap filter and the remote sampling probe or Tygon tubing. Make sure to set the dilution ratio in the programming mode so that the correct gas reading will be displayed when the dilution fitting is used. Dilution ratios often depend on the length of remote sampling tubing used. Therefore it is prudent to calibrate the actual dilution ratio and to check the operating instructions and technical notes for proper operation of the dilution fitting.

WARNING: For this application, the user must have the monitor located in a clean atmosphere outside the confined space and use a remote access probe or Tygon tubing to measure the gas concentration.

3.6 Calibration Adapter

The calibration adapter for the PGM-54 is a simple 6-inch Tygon tubing with a male Luer connector on one end. During calibration, simply connect the tubing to the water trap filter on MultiRAE IR and the calibration gas on the other side.

4. PROGRAMMING

The MultiRAE IR Monitor is built with a microcomputer to provide programming flexibility for the user. Authorized users can re-calibrate the monitor, change the alarm limits, change site ID, user ID, datalogging period, real time clock, etc.

Programming is menu-driven to provide intuitive end-user operation. The display shows the menu options, and the key pad is used for menu selection and data entry.

Note: The real time monitoring of the gas concentration continues while in the programming mode. However, during the calibration or review datalog procedures, the real time monitoring will pause until the procedures are completed. In addition, entering programming mode pauses the datalogging operation automatically. After exiting programming mode, datalogging operation will resume.

4.1 Programming Mode

The MultiRAE IR has three user modes: **text**, **display** and **programming** mode. The user can access the programming function only if they are in the programming mode (or from **text** mode with password). If the monitor is set to **display** mode, the user cannot enter the programming menu. In this case, the user mode can be changed only through a PC (see Section 5.0 for details on setting up the user mode).

The **programming** mode allows users to change the setup in the monitor, calibrate the monitor, modify the sensor configuration and enter user information, etc. The programming functions are organized in a three-tier menu structure. Table 4.1 shows the first tier of the programming menu. Each menu item includes several sub-menus to perform additional programming functions. Appendix A shows a more detailed menu tree structure.

Table 4.1

Programming Menu
Calibrate Monitor?
Change Alarm Limits?
View or Change Datalog?
Change Monitor Setup?
Change Sensor Configuration?

Security Level

There are three levels of security in the MultiRAE IR programming mode to provide further protection against unauthorized changes to the monitor alarm settings and other settings. **Level 2** security allows a user to enter programming mode without any restrictions. This is the default security setting. **Level 1** security requires a 4-digit password to enter programming mode. **Level 0** security allows a user to enter the programming mode without any password checking, as in Level 2. However, it does not allow a user to save any changes to the alarm limits, real time clock, correction factors, user and site information, etc. A user can still perform calibration with Level 0 security. The security level must be set using a computer.

Once inside the programming mode, the first menu will be displayed. Each subsequent menu item can be viewed by pressing the [N/-] repeatedly until the desired menu is displayed. To enter the sub-menu of a particular menu, press the [Y/+] key and the sub-menu will be displayed.

To exit the programming mode and return to the normal operation, press the [MODE] key at any of the first tier menu displays.

4.2 Keys for Programming Mode

The three keys perform a different set of functions during the programming mode as summarized below.

Table 4.2

Key	Function in Programming Menu
[MODE]	Exit menu when pressed momentarily or exit data entry mode when pressed and held for 1 second
[Y/+]	Increase numerical value for data entry or confirm (yes) for a question
[N/-]	Decrease numerical value for data entry or deny (no) for a question

4.3 Entering the Programming Menu

1. Turn on the MultiRAE IR monitor (refer to Section 2.3 for the power on sequence).
2. Press and hold down both [**MODE**] and [**N/-**] keys for three seconds to enter programming mode. **Note:** This is to prevent a user from entering the programming mode by accident.
3. If the security level is 0 or 2, after holding down the two keys for 3 seconds, the monitor should enter the programming mode and “Calibrate Monitor?” will be displayed.
4. If the security level is 1, or the unit is in text mode, after holding down the two keys for three seconds, the display will show “Enter Password = 0000” with the left-most digit flashing. Enter the password starting from this flashing digit.

Note 1: The factory default password programmed into the MultiRAE IR monitor is “0000”.

Note 2: For added security, “0000” is always displayed instead of the actual password at this step.

5. If the correct digit value is not “0”, use [**Y/+**] or [**N/-**] to increase or decrease the digit value. Then press [**MODE**] momentarily to confirm the digit value. The display shows the actual digit entered and moves the flashing cursor to the next digit (to the right).

6. Repeat Step 5 until all four digits are entered. Press and hold [**MODE**] for one second.
7. If the entered password is correct, the monitor enters the programming menu. The first menu item “Calibrate Monitor?” is displayed.
8. If the password is incorrect, the display shows “Wrong Password???” and returns to the regular display of instantaneous gas readings.
9. If the User mode is set to **display** mode, a message “Display Only! Cannot enter....” is shown.

4.4 Calibration

CALIBRATION WARNINGS:

The calibration of all newly purchased RAE Systems instruments should be tested by exposing the sensor(s) to known concentration calibration gas before the instrument is used or put into service.

For maximum safety, the accuracy of the MultiRAE IR should be checked by exposing the sensor(s) to known concentration calibration gas before each day's use.

Instruments with slowly responding sensors (e.g., HCN, PH₃, NH₃ & Cl₂) may require pre-exposure of the sensors to the gas before initiating calibration. Check to ensure that the instrument calibration time matches or exceeds the sensor response time.

In programming mode, the user may calibrate the sensors in the MultiRAE IR monitor. This is a two-point calibration process using “fresh air” and a standard reference gas. First, “fresh air” containing 20.9% oxygen and no detectable VOC, toxic or combustible gases is used to set the zero point for each sensor. Then a standard reference gas, containing a known concentration of a given gas, is used to set the second point of reference (also known as span gas). The two-point calibration procedure is detailed below. Table 4.3 shows the sub-menus for calibration operations.

Note 1: “Fresh air” calibration zeros only the LEL, VOC, and toxic gas sensors, and spans the O₂ sensor. The CO₂ sensor is spanned and zeroed in two sub-menus of the

Single Sensor calibration. The CO₂ sensor uses 100% N₂ as the zero gas. RAE Systems also supplies CO₂-free 100 ppm isobutylene, which is convenient to use to both zero the CO₂ sensor and span the VOC. The O₂ sensor is also zeroed in the Single Sensor Calibration, but does not require as frequent zeroing as the other sensors.

Note 2: For better accuracy, zero calibration should be performed before span calibration of all sensors.

Table 4.3

Calibration Sub-Menu
Fresh Air Calibration?
Multiple Sensor Calibration?
Single Sensor Calibration?
Modify Span Gas Value?
Change LEL/VOC Span Gas?

The MultiRAE IR can be calibrated either with gas from a sample bag (Tedlar® bag), directly from a bottle using a demand-flow type regulator, or from an open-tube (also open cup or Tee) that allows excess gas to escape past the inlet probe. In the latter method it is important that the gas flow is greater than the pump draw by at least 20%. The MultiRAE IR can also be calibrated directly from a cylinder using a fixed flow regulator with a flow rate between 0.5 and 1.0 liters per minute, although this method is less accurate than the other 3 methods by a few percent.

The calibration adapter links the inlet port of the MultiRAE IR Monitor to the gas sample bag (see Figure 4-1).



Figure 4-1 Connection of Calibration Gas

Note: Slowly responding sensors listed in the table below may require pre-exposure of the sensor to the gas immediately before initiating the calibration sequence. Some firmware versions use a fixed 75-second calibration time; some newer versions automatically apply the full calibration time. After completing the zero calibration, expose the unit to the gas for the pre-exposure time listed below if a fixed 75-second countdown time is programmed.

Sensor	Response Time t_{90} (sec)	Total Calibration Time (sec)	Pre-exposure Time for 75-sec Calibration Time
HCN	200	230	155
ClO ₂ , NH ₃	150	150	75
Cl ₂ , PH ₃	60	120	45

PROGRAMMING

CO, H ₂ S, SO ₂ , NO, NO ₂ , O ₂ , LEL, VOL	≤40	60	0
---	-----	----	---

4.4.1 Fresh Air Calibration

This procedure determines the zero point of the calibration curve for LEL, VOC, and toxic gas sensors. To perform fresh air calibration, the calibration adapter and a bottle of “fresh” air (optional) are used. The “fresh” air is clean dry air with 20.9 % oxygen concentration and without any organic, toxic or combustible gases or impurities. If such an air bottle is not available, any clean ambient air without detectable contaminant can also be used. A charcoal filter should be used if one is not sure of the ambient air’s purity. Note, however, that charcoal will not remove highly volatile gases such as propane, CH₄, H₂ or CO₂.

1. “Calibrate Monitor?” is the first menu item in Table 4.1. Press [Y/+] to perform calibration. The first sub-menu shows: “Fresh Air Calibration?”
2. If a “fresh” air bottle is available, twist the calibration adapter over the inlet port of the monitor and connect the other end of the tube to the fresh gas bottle. If a “fresh” air bottle is not available, simply leave the monitor in an area free of any detectable vapor.
3. Press the [Y/+] key to start “fresh air calibration” of the monitor. The display shows “zero ...in progress” followed by the name of each sensor and the message “zeroed”. The display should show a reading of “20.9” for the oxygen sensor and “0.0”, or a very small number, for all other sensors.
4. After about a 5 second pause, the display will show the message “Zero Cal Done!” and move to the next sub-menu “Multiple Sensor Calibration?”

4.4.2 Multiple Sensor Calibration

This function simultaneously determines the second point of calibration curves for multiple sensors in the monitor. Mixed standard reference gases are needed to perform this procedure. Several possible gas mixtures can be used; RAE Systems recommends the four-gas mix (50% LEL CH₄, 20.9% O₂, 50 ppm CO, and 5000 ppm CO₂, balance N₂, p/n: 600-0129-000) for multiple-sensor calibration of units with CO sensors. Simply connect the tube to the sampling bag filled with mixed gas as shown in Figure 4-1.

Note: Slowly responding sensors may require pre-exposure to gas before initiating the calibration sequence. See Section 4.4 introduction for details.

1. Continuing from Step 4 of the previous section, the display shows “Multiple Sensor Calibration?” Press [Y/+]. The display shows all the pre-selected gases for calibration and an “OK?” question. Press [Y/+] to accept the sensor selections and start the calibration, or [N/-] to modify the sensor selection (skip to Step 6).

TOX1	VOC	TOX2
CO	---	CO₂
LEL	OK?	OXY
LEL		OXY

2. Turn on the valve of the sampling bag to start the flow of the span gas. Display shows “Apply Mixed Gas” and will wait for the calibration gas to reach the sensor. When the calibration gas has reached the sensor the display will show “calibration in progress... 75” with

the countdown timer shows the number of remaining seconds while the monitor performs calibration. When the timer reaches 0, the display shows the name of each sensor, the message “cal’ed!” and the calibrated values for each gas. If no gas has reached the sensor after 75 seconds, the display will show “No gas flow...” and abort the calibration.

Note: In ambient air, there exists at least 340 ppm of CO₂, so if the CO₂ sensor is enabled in the instrument and no gas flow exists, there will still be a span signal and the “No gas flow...” will not be displayed.

Note: The readings should be close to the span gas values. After about 5 seconds pause, the display will show the message “Span Cal Done! Turn Off Gas”

3. This completes the multiple sensor calibration procedure and moves to the next sub-menu item.
4. Turn off the flow of gas. Disconnect the calibration adapter from the MultiRAE IR Monitor.
5. If the sensor failed the calibration, the sensor name and an error message “failed, continue?” will appear. Press [N/-] or [MODE] to abort the calibration and move directly to the next sub-menu. Press [Y/+] to continue the next sensor calibration. In either case, the calibration data for the current sensor are not changed.
6. From Step 1, if the [N/-] key is pressed, the display shows all the sensor names that are selected for multiple sensor calibration with the cursor blinking at the first sensor location.

TOX1	VOC	TOX2
CO*	VOC	CO₂*
LEL*	OK?	OXY
LEL		OXY

Press [Y/+] to select the sensor and [N/-] to de-select the sensor. A previously selected sensor will show an “*” next to the sensor name. A previously de-selected sensor will not show an “*” next to the sensor name.

7. Press [MODE] momentarily to move from one sensor location to the next. Repeat Step 7 until all of the sensors that need to be calibrated during multiple sensor calibration are selected. Press and hold the [MODE] key for 1 second to save the new sensor selection.
8. The display shows “Save?” To confirm the new selection, press the [Y/+] key to accept the change and continue on with Step 2. Press [N/-] or [MODE] to discard the change and to continue on with Step 2.

Cross Sensitivity: Some sensors may show cross-sensitivity to other gases. Therefore, it is important to choose the gas mixture carefully for the multiple sensor calibration to avoid erroneous calibration due to cross sensitivity. For example, some VOC gases are known to respond on the CO sensor, and CO₂ is a common impurity in calibration gas mixtures. In general, it is recommended to calibrate the two toxic sensors, combustible and oxygen sensor with a bottle of mixed gas using the multiple sensor calibration procedure and to calibrate the PID sensor with a bottle of a single VOC gas.

4.4.3 Single Sensor Calibration

This procedure determines the second point of the sensor calibration curve for a single sensor. A standard reference gas is needed to perform this procedure. Table 2.2 shows the standard calibration gas that is typically used as the span gas in the factory. Connect the tube to the sampling bag filled with the standard gas as shown in Figure 4-1.

1. Continuing from Step 4 or Step 6 of the previous section, the display should show “Single Sensor Calibration?” Press [Y/+]. The display shows all the installed sensors in the monitor with the cursor blinking at the first sensor location. Press [Y/+] key to select the highlighted sensor and start the calibration, or press [MODE] key momentarily to move to the next sensor location.

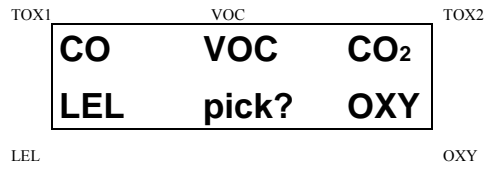

Turn on the valve of the gas bottle (e.g., CO) to start the flow of the span gas. Display shows “Apply CO Gas” and will wait for the calibration gas to reach the sensor. When the calibration gas has reached the sensor the display will show “calibration in progress...60” with the countdown timer shows the number of remaining seconds while the monitor performs calibration. When the countdown timer reaches 0, the display shows the sensor name and the calibrated value:

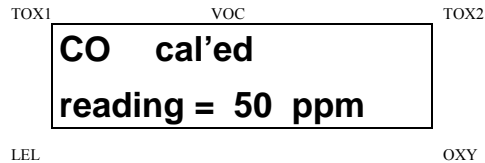

If no gas has reached the sensor after 75 seconds, the display will show "No gas flow..." and abort the calibration.

Note: The reading should be very close to the span gas value. After about 5 seconds pause, the display will show the message "Span Cal Done! Turn Off Gas"

3. This completes the single gas calibration procedure for one sensor. The display shows the single gas calibration sub-menu for a user to select another sensor or move to next calibration sub-menu.
4. Turn off the flow of gas. Disconnect the calibration adapter from the MultiRAE IR Monitor.
5. Repeat Step 1 to Step 5 to calibrate the next sensor.
6. Press [**MODE**] any time during Step 2 to reduce waiting time. If the sensor fails the calibration, the sensor name and an error message "failed, continue?" will appear. Press [**N/-**] or [**MODE**] to abort the calibration and move directly to the next sub-menu item. Press [**Y/+**] to continue the single gas calibration. In either case, the current calibration data will not be changed.

Oxygen Sensor Calibration

The oxygen sensor calibration is slightly different from all other sensors. During “fresh” air calibration, the oxygen sensor is calibrated to a fixed value of 20.9% oxygen. During single sensor calibration, the oxygen sensor can either be zeroed with inert gas or spanned to an oxygen concentration different than 20.9%, e.g. 19.5%. When the O₂ sensor is selected for single gas calibration, the question “0% Oxygen?” is displayed. Enter [Y/+] and apply the inert gas (e.g., nitrogen, argon, etc.) to zero the oxygen sensor. Otherwise, enter [N/-] to calibrate the oxygen sensor to a different span oxygen value. During both single and multiple sensor calibrations, the oxygen sensor is calibrated to the span value defined in Section 4.4.4. and overwrites the fresh air span to 20.9% O₂.

Note 1: After a “0% oxygen” calibration, the user must perform a fresh air or single sensor OXY calibration to ensure that the oxygen sensor is calibrated correctly.

Note 2: The most recent span calibration overwrites any previous span calibration, whether it is performed during “fresh air zero” or single sensor calibration. Therefore, to retain calibration data to a lower O₂ concentration, avoid another fresh air calibration (which will reset the span to 20.9%).

CO₂ Sensor Calibration

The CO₂ sensor is zeroed and in a sub-menu of the Single Sensor calibration and spanned in either Single or Multiple sensor calibration functions. During “fresh” air calibration, the CO₂ sensor does nothing. When the CO₂ sensor is selected for Single Sensor calibration, the question “0% CO₂?” is displayed. Enter [Y/+] and apply pure nitrogen gas or 100 ppm isobutylene to calibrate the CO₂ sensor to 0 ppm CO₂ (isobutylene supplied by RAE is free of CO₂). When this zero calibration is complete, re-enter the Single Sensor calibration mode and enter [N/-] to the “0% CO₂?” question. Next, supply the CO₂ span gas, typically 5,000 ppm, to calibrate the CO₂ sensor. Alternatively, perform the CO₂ span in the Multiple Sensor calibration mode with a mixed gas. During either Single or Multiple sensor calibration, the CO₂ sensor is calibrated to the span value defined in Section 4.4.4. However, it is a good practice to perform a zero calibration before span calibration.

Note: After a “0% CO₂” calibration, the user must perform a span calibration to ensure that the CO₂ sensor is calibrated correctly.

Calibration Time Stamp

When a Single or Multiple sensor calibration is performed, a time stamp will be stored in the non-volatile memory. This information will be included in the datalogging report.

4.4.4 Modify Span Gas Value

This function allows the user to change the span values of the standard calibration gases.

1. “Modify Span Gas Value?” is the next sub-menu item in Table 4.3.
2. Press **[Y/+]** key. Display shows:

TOX1	VOC	TOX2
50	100	
	5000	
50	span	20.9

LEL OXY

The cursor is blinking at the first digit of the first Span value. If the user wants to modify any one of the span gas value, go to Step 3. Otherwise, press and hold the **[MODE]** key for 1 second to accept the previously stored span gas value and move to the next calibration sub-menu.

3. Starting from the left-most digit of the span gas value, use **[Y/+]** or **[N/-]** key to change the digit value and press **[MODE]** key momentarily to advance to next digit, the cursor will move to the next digit to the right. Repeat this process until all span gas values are entered. Press and hold the **[MODE]** for 1 second to save the new calibration gas value.

4.4.5 4. The display shows “Save?” To confirm the new value press the [Y/+] key to accept the change. Press the [N/-] key or the [MODE] key to discard the change and move to the next calibration sub-menu.

4.4.5 Change LEL/VOC Span Gas

This function allows the user to select a specific LEL or VOC gas to be used as the span gas during LEL or VOC gas calibration.

1. “Change LEL/VOC Span Gas?” is the next sub-menu item in Table 4.3.
2. Press **[Y/+]** key. If LEL sensor is installed and enabled, the display shows:

TOX1	VOC	TOX2
LEL Span = ?		
Methane		
LEL		OXY

Otherwise, the message “No LEL installed” will appear.

3. If the user does not want to change the LEL span gas, press **[Y/+]** key to accept the current selection and exit this sub-menu.
4. If the user wants to select a different LEL span gas, press **[N/-]** key. Then use **[Y/+]** or **[N/-]** key to scroll through a list of gas names until a desired gas name appears in the LCD display, then press **[MODE]** key to select the new gas name.
5. The display shows “Save?” To confirm the new gas selection, press the **[Y/+]** key to accept the change. Press the **[N/-]** key or the **[MODE]** key to discard the change and move to the next display.

6. If the VOC sensor is installed and enabled, the display shows:

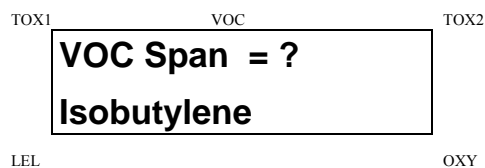

The display shows a rectangular box with the text "VOC Span = ?" on the top line and "Isobutylene" on the bottom line. The box is centered on the screen. Above the box, the label "VOC" is centered. To the left of the box, the label "TOX1" is positioned. To the right of the box, the label "TOX2" is positioned. Below the box, the label "LEL" is on the left and "OXY" is on the right.

Otherwise, the message “No VOC installed “ will appear.

7. If the user does not want to change the VOC span gas, press [Y/+] key to accept the current selection and exit this sub-menu.
8. If the user wants to select a different VOC span gas, press [N/-] first. Then use the [Y/+] or [N/-] keys to scroll through the list of gas names until the desired gas name appears in the display, and press [MODE] to select the new gas name.
9. The display shows “Save?” To confirm the new gas, press the [Y/+] key to accept the change. Press the [N/-] key or the [MODE] key to discard the change and return to the first calibration sub-menu.

4.5 Change Alarm Limits

The alarm limits of each sensor can be changed as shown in Table 4.4.

Table 4.4

Alarm Limit Sub-Menu
Change High Alarm limit?
Change Low Alarm limit?
Change STEL alarm limit?
Change Average alarm limit?

- The average alarm limit can be “Running Average” or “TWA (Time Weight Average) depending on the menu selection on “Change Averaging Method” (see Section 4.7.8). Press [N/-] to cycle through the sub-menu. Press [Y/+] to enter a sub-menu and the display shows “HIGH”, “LOW”, “STEL”, “TWA” or “AVG” with a flashing cursor on the left-most digit of the previously stored alarm limits.

TOX1	VOC	TOX2
200	100.0	
	8000	
20	HIGH	
23.5		
LEL		OXY

TOX1	VOC	TOX2
35	50.0	
	5000	

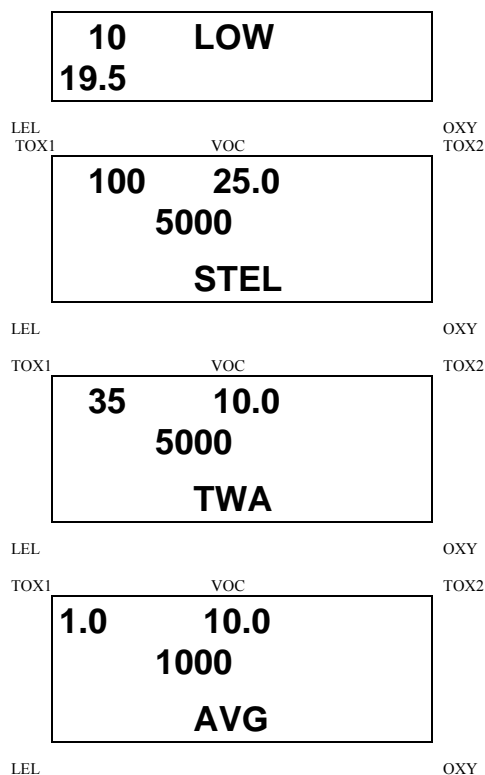

2. To modify this limit, starting from the left-most digit, use the [Y/+] or [N/-] key to change the digit value and press the [MODE] key momentarily to advance to the next digit. The flashing digit will move on to the next digit to its right. Repeat this process until all the new Alarm limits are entered. Press and hold the [MODE] key for 1 second to exit data entry mode. If there is any change to the existing value, the display shows "Save?" Press the [Y/+] key to accept the new value and move to the next sub-menu. Press the [N/-] key to discard the changes. To preserve the previously stored alarm limit, press and hold the [MODE] key for 1 second and the monitor will exit data entry mode and move to the next sub-menu.

4.6 View or Change Datalog

MultiRAE monitor calculates and stores the gas readings at a specified interval. The user can review these stored readings or change datalog setup from the programming mode. Users can also program additional datalog options in PC and down loaded them to the monitor (see Section 5.0 for details on how to program additional datalogging options). Table 4.5 shows the sub-menus for datalog options:

Table 4.5

Datalog Sub-Menu
Reset Peak and Minimum?
Clear All Data?
Change Datalog Period?
Select Data Type?
View Datalog?
Enable / Disable Datalog?
Select Memory Full Type?

4.6.1 Reset Peak and Minimum

This function will reset peak and minimum data stored in the non-volatile data memory.

1. “Reset Peak and Minimum?” is the first sub-menu item in Table 4.5.
2. Press the [Y/+] key to clear the peak and minimum data memory. Display shows “Are You Sure?” to re-confirm whether to reset peak and minimum data.
3. Press the [Y/+] key again will reset peak and minimum data.
4. Press the [N/-] or [MODE] key to exit without resetting the data and move to next datalog sub-menu.

Note: STEL and TWA (or AVG) value will not be affected when peak and minimum values are reset.

4.6.2 Clear All Data

This function will erase all data stored in the non-volatile data memory. This does not change STEL, TWA, Peak, minimum concentration and run time values, which are stored in a different location.

1. “Clear All Data?” is the next sub-menu item in Table 4.5.
2. Press the [Y/+] key to clear the data memory. Display shows “Are You Sure?” to re-confirm the clearing of memory.
3. Press the [Y/+] key again will erase all the data memory.
4. Press the [N/-] or [MODE] key to exit without clearing the data memory and move to next datalog sub-menu.

4.6.3 Change Datalog Period

The datalog period can be programmed from 1 to 3,600 seconds (1 hour).

1. “Change Datalog Period?” is the next sub-menu item in Table 4.5.
2. Press the [Y/+] key, the display shows “New Period = 00xx” with the left-most digit flashing, where “00xx” is the previously stored datalog period.
3. To modify this period, starting from the left-most digit, use the [Y/+] or [N/-] key to change the digit value and press the [MODE] key momentarily to advance to the next digit. The flashing digit will move to the next digit to the right. Repeat this process until all 4 digits of the new period are entered. Press and hold the [MODE] key for 1 second to exit data entry mode. If there is any change to the existing value, the display will show “Save?” Press the [Y/+] key to accept the new value and exit the datalog sub-menu. Press the [N/-] key to discard the changes and move to the next menu option.
4. To preserve the previously stored period, press and hold the [MODE] key for 1 second. The monitor will exit data entry mode and move to the next sub-menu item in Table 4.5.

4.6.4 Select Data Type

The user can choose to store either the average or the peak value during each datalog period.

1. “Select Data Type?” is the next sub-menu item in Table 4.5.
2. Press the [Y/+] key, the display shows the current data type: “Data Type = Average?”
3. Press the [Y/+] key to accept the currently displayed data type. Press [N/-] key to change to the other data type: “Data Type = Peak?” Press [MODE] key to exit this sub-menu and move on to the next sub-menu.
4. If there is any change to the existing selection, pressing the [Y/+] key and the display will show “Save?” Then press [Y/+] to accept or [N/-] to discard and move to the next sub-menu.

Note: It is necessary to select “Average” data type in order to calculate the correct STEL and TWA data for the datalogging report.

4.6.5 View Datalog

This function allows the user to review all the data that is stored in the non-volatile data memory.

1. “View Datalog?” is the next sub-menu item in Table 4.5. Press the [Y/+] key and the LCD display shows the first event number and start date and time of the event.

TOX1	VOC	TOX2
Event # 1 ?		
8/28/01 8:20		
LEL		OXY

2. Press [Y/+] to review data of the first event. The LCD display shows the stored data of each sensor and the time stamp:

TOX1	VOC	TOX2
1 0.0		
880		
2 +/-		
20.5		
LEL		OXY

3. Press the [Y/+] or [N/-] key to move forward or backward to view other data of this event. When reaching the end or the beginning of the event, the message “Start of data!” or “End of data!” will appear. Press [MODE] to exit the current event.
4. Press [N/-] at Step 2 to see next event. If there are no more events, the message “No more event! Quit?” will appear. Press [N/-] to go back to the first event or press [Y/+] to exit and move to the next sub-menu.

4.6.6 Enable / Disable Datalog

The user can choose to enable or disable the datalogging function on each individual sensor. This allows users to selectively log certain sensor readings of interest.

1. “Enable / Disable Datalog?” is the next sub-menu item in Table 4.5. Press [Y/+]. All sensors selected to be datalogged are marked with an “*” next to the sensor name. The cursor is blinking at the first sensor location. Press [Y/+] to enable the datalogging for the sensor and [N/-] to disable the datalogging.

TOX1	VOC	TOX2
CO*	VOC	CO ₂ *
LEL*	pick	OXY*
LEL		OXY

2. Press [MODE] to move from one sensor location to the next one. Repeat until all the sensors that need datalogging are selected. Press and hold [MODE] for 1 second to save the new sensor selection. When the display shows “Save?”, press [Y/+] to accept the change. Press [N/-] or [MODE] to discard the change and return to the first datalog sub-menu.

4.6.7 Select Memory Full Type

“Select memory full type?” allows the user to decide how the data are stored. Two options are available when the memory becomes full, either the memory begins to “wrap around”, overwriting the oldest data, or it can “Stop” storing any more data. The usual [Y/+], [N/-] and [MODE] selection procedures are used to set the desired type.

4.7 Change Monitor Setup

In this menu, the user may change monitor setup parameters or enter user information. Table 4.6 shows the sub-menus for changing the monitor.

Table 4.6

Monitor Setup Sub-Menu
Change Site ID?
Change ID Mode?
Change User ID?
Change Alarm Mode?
Change User Mode?
Change Real Time Clock?
Change Backlight Mode?
Change Password?
Change Pump Speed?
Change Averaging Method?
Change Display Language?
Set Temperature Unit?

4.7.1 Change Site ID

The user can enter an 8 digit alphanumeric site ID in the programming mode. This site ID will be included in the datalog report.

1. “Change Site ID?” is the first sub-menu in Table 4.6.
2. Press [**Y/+**] to enter the sub-menu. The display shows the current site ID: “Site ID = xxxxxxxx” with the left most digit flashing.
3. Press [**Y/+**] or [**N/-**] to cycle through all 26 letters and 10 numerals. Press [**MODE**] momentarily to advance to the next digit. The flashing digit will move to the next digit to the right. Repeat this process until all 8 digits of the new site ID are entered.
4. Press and hold the [**MODE**] key for 1 second to exit the data entry mode and move to the next monitor setup sub-menu.
5. If there is any change to the existing site ID, the display shows “Save?” Press the [**Y/+**] key to accept the new site ID and exit the monitor setup sub-menu. Press the [**N/-**] key to discard the changes and move to the next sub-menu.

4.7.2 Change ID Mode

The ID Mode can be toggled on or off in this menu. When the ID Mode is enabled, the unit requests that the user enter an ID whenever the unit is turned on. In this way any logged data can be associated with a particular user.

1. “Change ID Mode?” is the next sub-menu in Table 4.6.
2. Press [**Y/+**] and the display shows the current mode: “User ID Mode = Yes?” or “User ID Mode = No?”.
3. Press [**N/-**] to toggle between “Yes” and “No”. Press [**MODE**] momentarily to advance to the next digit.
4. Press [**Y/+**] to accept the current setting, or press [**MODE**] to skip to the next monitor setup sub-menu without any change.
5. If there is any change to the existing site ID, the display shows “Save?” Press [**Y/+**] to accept the new site ID and exit the monitor setup sub-menu. Press [**N/-**] or [**MODE**] to discard the changes and move to the next sub-menu.

4.7.3 Change User ID

The user can enter an 8 digit alphanumeric user ID in the programming mode. This user ID will be included in the datalog report.

1. “Change User ID?” is the next sub-menu in Table 4.6.
2. Press **[MODE]** to enter the sub-menu. The display shows the current user ID: “User ID = xxxxxxxx” with the left most digit flashing.
3. Press **[Y/+]** or **[N/-]** to cycle through all 26 letters and 10 numerals. Press **[MODE]** momentarily to advance to the next digit. The flashing digit will move to the next digit to the right. Repeat this process until all 8 digits of the new user ID are entered.
4. Press and hold the **[MODE]** key for 1 second to exit the data entry mode and move to the next monitor setup sub-menu.

4.7.4 5. If there is any change to the existing user ID, the display shows “Save?” Press [Y/+] to accept the new user ID and exit the monitor setup sub-menu. Press [N/-] to discard the changes and move to the next sub-menu

4.7.4 Change Alarm Mode

There are two different alarm modes: **latched** and **automatic reset** in MultiRAE IR that can be selected from the programming menu.

1. “Change Alarm Mode?” is the next sub-menu in Table 4.6.
2. Press the [Y/+] key, and the display shows the current alarm mode selection: “Alarm Mode = Latched?”
3. Press the [Y/+] key to accept the currently displayed alarm mode. Press [N/-] to change to the other alarm mode: “Alarm Mode = Auto Reset?” Press [MODE] to exit this sub-menu and move to the next monitor setup sub-menu.
4. If there is any change to the existing selection, press [Y/+] and the display will show “Save?” Then, press [Y/+] to accept or [N/-] to discard and move to the next sub-menu.

4.7.5 Change User Mode

There are three different user modes: **text**, **display** and **programming** in MultiRAE IR that can be selected from the programming menu.

1. “Change User Mode?” is the next sub-menu in Table 4.6.
2. Press the [Y/+] key, and the display shows the current user mode selection: “User Mode = Program?”
3. Press the [Y/+] key to accept the currently displayed user mode. Press [N/-] to scroll through the other two user modes. Press [MODE] to exit this sub-menu and move to the next monitor setup sub-menu.
4. If there is any change to the existing selection, press [Y/+] and the display will show “Disable Program! Are you Sure?” Then, press the [Y/+] key to accept or the [N/-] key to discard and move to the next sub-menu.

4.7.6 Note: If the user mode is changed to display or text mode, it is no longer possible to enter the programming menu. Therefore, the user cannot change back to program mode from the monitor. The only way to change the user mode back to “program” mode is to use a PC and the ProRAE-Suite program or “multicfg” program.

4.7.6 Change Real Time Clock

The MultiRAE monitor is equipped with a real time clock. The user can enter the correct date and time in the programming mode.

1. The next sub-menu item in Table 4.6 is “Change Real Time Clock?”
2. Press [**Y/+**] and the display shows the current date and time: “Date = mm / dd/ yy” and “Time = hh : mm” with the left most digit of the date flashing.
3. To modify this value, use the [**Y/+**] or [**N/-**] key to change the digit value and press the [**MODE**] key momentarily to advance to the next digit. The flashing digit will move on to next digit to its right. Repeat this process until the new date and time values are entered. Press and hold the [**MODE**] key for 1 second to exit data entry mode. If there is any change to the existing value, the display shows “Save?” Press the [**Y/+**] key to accept the new value and move to next sub-menu. Press the [**N/-**] key to discard the changes and move to next sub-menu.

4.7.7 Change Back Light Mode

The MultiRAE monitor allows a user to choose to turn on and off LCD back light automatically when ambient light falls below or above a threshold level or to turn on and off the back light manually by pressing the [N/-] key.

1. The next sub-menu in Table 4.6 is “Change Back light Mode?”
2. Press [Y/+] and the display shows the current back light mode: “Back Light Mode = manual turn on?”
3. Press the [Y/+] key to accept the currently displayed back light mode. Press [N/-] to change to the other back light mode: “Back Light Mode = manual turn on?” Press [MODE] to exit this sub-menu and move to the first monitor setup sub-menu.
4. If there is any change to the existing selection, pressing the [Y/+] key and the display will show “Save?” Then, press the [Y/+] key to accept or the [N/-] key to discard and move to the next sub-menu.

4.7.8 Change Password

The user can modify the password from the monitor.

1. The next sub-menu in Table 4.6 is “Change Password?”
2. Press the [Y/+] key and the display shows the current password: “Enter new password = xxxx” with the left most digit flashing.
3. Press the [Y/+] or [N/-] key to cycle through all 10 numerals. Press [MODE] key momentarily to advance to the next digit. The flashing digit will move to the next digit to the right. Repeat this process until all 4 digits of the new password are entered.
4. Press and hold the [MODE] key for 1 second to exit the data entry mode and move to the next monitor setup sub-menu.
5. If there is any change to the existing password, the display shows “Save?” Press the [Y/+] key to accept the new password. Press the [N/-] key to discard the changes and move to the next sub-menu.
6. The monitor next asks for this value to be confirmed. “Confirm New Password = 0000” with the left most digit flashing. The number must be reentered as before to exit the monitor setup sub-menu. If misentered the second time, the password reverts to its original setting.

4.7.9 Change Pump Speed

There are two speed settings for the pump motor in the MultiRAE IR that can be selected from the programming menu: **low** (default) and **high**. The “high” setting should be used for long lengths of tubing or when rapid changes in input conditions are expected. “Low” may be selected when the operating conditions are slow to change. Low may also be used to prolong pump motor life, LEL sensor life and battery run time.

1. “Change Pump Motor Speed?” is the next sub-menu in Table 4.6.
2. Press [**Y/+**] and the display shows the current pump speed selection: “Pump Speed = Low?”
3. Press the [**Y/+**] key to accept the currently displayed pump speed and move to the next monitor setup sub-menu. Press [**N/-**] to change to the other speed “Pump Speed = High?” Press [**MODE**] to exit this sub-menu and move to the next monitor setup sub-menu.

4.7.10 Change Averaging Method

There are two methods of calculation used in the averaging of the monitor. Using this selection can cause the calculation to be performed using an eight-hour time weighted average (TWA), the default, or a running average (AVG). The display indicator for whichever averaging type is selected will show on the LCD display wherever the average is indicated.

1. “Change Averaging Method?” is the next sub-menu item in Table 4.6. Press [Y/+] and the display shows the current average selection: “Average Type = TWA?”
2. Press the [Y/+] key to accept the current display. Press [N/-] to change to the other selection: “Average Type = Running Average?”, and [Y/+] to select.
3. If there is any change to the existing selection, pressing the [Y/+] key, the display will show “Save?” Then, press the [Y/+] key to accept or the [N/-] key to discard and move to the first setup sub-menu.

4.7.11 Change Language? & Set Temperature Unit?

Change Language allows switching to another language if desired and if installed. Set Temperature Unit allows displaying the temperature in either degrees Centigrade or Fahrenheit. The usual [Y/+] , [N/-] and [MODE] selection procedures are used to set the desired type.

4.8 Change Sensor Configuration

In the programming mode, users may change several sensor related configurations of the MultiRAE IR monitor. Table 4.7 shows the sub-menus for setting various configurations of the sensors.

Table 4.7

Sensor Configuration Sub-Menu
Change LEL/VOC Gas Selection?
Enable / Disable Sensors?
Change Dilution Ratio?
Change PID Lamp Type?

Correction Factors

The PID and LEL sensors used in MultiRAE IR respond to a broad range of gases. Typically, these sensors show a different sensitivity to different gases. The correction factor for a specific gas is defined as:

$$\text{Correction Factor} = \frac{\text{Sensitivity to a calibration gas}}{\text{Sensitivity to a specific gas}}$$

Correction factors (CFs) are often used to obtain a calculated concentration of a specific gas while using a different gas during calibration. See Appendix B for a list of factors. CFs for the LEL sensor are defined relative to methane calibration gas. CFs for the PID are defined relative to isobutylene calibration gas.

The MultiRAE IR monitor stores three sets of correction factors: one for the LEL sensor, one for the 10.6 eV PID sensor and the other for the 11.7 eV PID sensor. Each set consists of 20 to 40 different gases. The user can choose one gas from the list to be the calibration gas and another gas to be the measurement gas.

For example, the user can choose propane as the calibration gas for the LEL sensor and select pentane as the measurement gas. The monitor then calculates the correction factor between these two gases and converts the measured value of the LEL sensor into an equivalent concentration of pentane. In this example, with propane calibration, the new CF is calculated as:

$$\text{CF} = \frac{\text{CF of measurement gas}}{\text{CF of calibration gas}} = \frac{\text{CF of pentane}}{\text{CF of propane}} = \frac{2.2}{1.9} = 1.2$$

This calculation is done automatically and therefore the user should allow the instrument to calculate the factor 1.2 and not modify it manually it for pentane. The user should simply verify the factors 2.2 for pentane and 1.9 for propane. If methane is used as the calibration gas, the CF is simply the value in the pre-preprogrammed library because the CF for methane is defined as 1.0. Similarly, the user can choose one VOC gas for calibration and another VOC gas for measurement, and the monitor will calculate the new CF and apply it to the readings. The VOC correction factors differ with the different energies of the UV lamps used in the PID sensor. The user needs to select the correct type of UV lamp (10.6 eV or 11.7 eV) in Section 4.8.4 in order for the monitor to calculate the correction factor properly.

4.8.1 Change LEL/VOC Gas Selection

This function allows users to choose one of the pre-stored LEL or VOC gases and calculate its correction factor relative to the LEL or VOC calibration gas. This factor is used during gas measurements to show the equivalent concentration of the selected LEL or VOC gas. The user can also modify this relative correction factor to increase or decrease the gas reading. This allows users to create a custom factor for a specific gas or mixture of gases.

1. “Change LEL/VOC Gas Selection?” is the first sub-menu item in Table 4.7.
2. Press [Y/+]. If an LEL sensor is installed and enabled, the display shows:

TOX1	VOC	TOX2
<p>LEL Gas = ?</p> <p>Methane</p>		

Otherwise, the message “No LEL installed” will be displayed and skip to Step 8.

3. If the user does not want to change the LEL measurement gas, press [Y/+] to accept the current gas and skip to Step 6.
4. If the user wants to modify the LEL measurement gas, press [N/-] first, then use [Y/+] or [N/-] to scroll through a list of gas names until the desired gas name appears in the LCD display, then press [MODE] to select the new gas name.

- The display shows “Save new gas?”. To confirm the new gas, press the [Y/+] key to accept the change. Press the [N/-] key or the [MODE] key to discard the change and move to the next step.

- Display shows

TOX1 VOC TOX2

Methane
LELFactor=1.00 ?

LEL OXY

where “1.00” is the calculated correction factor of the selected gas in Step 4.

- If the user does not want to modify the LEL correction factor, press [Y/+] key and go to Step 8. To modify this factor, press [N/-] key first. Then starting from the left-most digit, use the [Y/+] or [N/-] key to change the digit value and press the [MODE] key momentarily to advance to the next digit. The flashing digit will move on to next digit to its right. Repeat this process until all 4 digits of the new factor are entered. Press and hold the [MODE] key for 1 second to exit data entry mode. If there is any change to the existing value, the display shows “Save?” Press the [Y/+] key to accept the new value and exit the gas selection sub-menu. Press the [N/-] key to discard the changes.

8. If the VOC sensor is installed and enabled, the display will show:

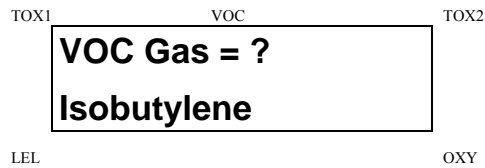

Otherwise, the message “No VOC installed” will be displayed and move to the next sub-menu.

9. To keep the current VOC measurement gas, press **[Y/+]** to accept the gas and go to Step 12.
10. To modify the VOC measurement gas, press **[N/-]** first, then use **[Y/+]** or **[N/-]** to scroll through a list of gas names until the desired gas name appears in the display. Finally press **[MODE]** to select the new gas name.
11. The display shows “Save?” To confirm the new gas, press the **[Y/+]** key to accept the change. Press the **[N/-]** key or the **[MODE]** key to discard the change and move to the next step.

12. The display shows

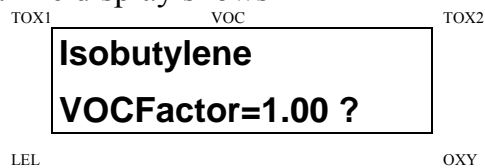

where “1.00” is the calculated correction factor of the selected gas in Step 10.

13. If the user does not want to modify the VOC correction factor, press **[Y/+]** and exit the sub-menu. To modify this factor, press **[N/-]** first. Then starting from the left-most digit, use the **[Y/+]** or **[N/-]** key to change the digit value and press the **[MODE]** key momentarily to advance to the next digit. The flashing digit will move on to next digit to its right. Repeat this process until all 4 digits of the new factor are entered. Press and hold the **[MODE]** key for 1 second to exit data entry mode. If there is any change to the existing value, the display shows "Save?" Press the **[Y/+]** key to accept the new value and exit the gas selection sub-menu. Press the **[N/-]** key to discard the changes.

4.8.2 Enable / Disable Sensor

This function allows the user to selectively enable or disable individual sensors in the MultiRAE IR monitor. When a sensor is disabled, the sensor will not measure nor display the gas concentration.

1. “Enable / Disable Sensors?” is the next sub-menu item in Table 4.7.
2. Press [Y/+]. The display shows all the installed sensors in the monitor. A previously enabled sensor is marked by an “*” next to the sensor name. The cursor will blink at the first sensor location. Press [Y/+] to enable the sensor and [N/-] to disable the sensor. A previously disabled sensor will show “----” instead of the sensor name.

TOX1	VOC	TOX2
CO*	VOC	CO2*
LEL*	pick	OXY*

3. Press [MODE] momentarily to move from one sensor location to the next one. Repeat Step 2 until all the sensors which needs to be enabled are selected. Press and hold [MODE] for 1 second to save the new sensor selection.
4. The display shows “Save?” To confirm the new selection, press the [Y/+] key to accept the change. Press the [N/-] key or the [MODE] key to discard the change and move to the next sub-menu.

4.8.3 Change Dilution Ratio

The user can insert an optional dilution fitting on the MultiRAE IR gas inlet port to dilute the gas sample. The user can enter a dilution ratio (from 1 to 10) from the programming menu so that the reading can be compensated to show the actual concentration of the gas sample with the dilution fitting.

1. “Change Dilution Ratio?” is the next sub-menu item in Table 4.7.
2. Press the **[Y/+]** key, the display shows the current dilution ratio: “Dilution Ratio = xx” with the left most digit flashing.
3. Press the **[Y/+]** or **[N/-]** key to increase or decrease the value of the digit. Press **[MODE]** key momentarily to advance to the next digit. The flashing digit will move to the next digit to the right. Repeat this process until both digits of the new dilution ratio are entered.
4. Press and hold the **[MODE]** key for 1 second to exit the data entry mode and move to the next sub-menu.
5. If there is any change to the existing dilution ratio, the display shows “Save?” Press the **[Y/+]** key to accept the new ratio and exit the sub-menu. Press the **[N/-]** key to discard the changes and move to the next sub-menu.

4.8.4 Change PID Lamp Type

This menu only applies to monitors equipped with a PID. There are three different energy UV lamps available for the PID sensor: 9.8 eV, 10.6 eV and 11.7 eV. Built-in Correction Factors are available for the 10.6 and 11.7 eV lamps. The user can select either lamp from the programming menu.

1. “Change PID Lamp Type?” is the next sub-menu item in Table 4.7.
2. Press the [Y/+] key, the display shows the current PID lamp selection: “PID Lamp = 10.6 eV?”
3. Press the [Y/+] key to accept the currently displayed PID lamp. Press [N/-] key to change to another lamp. Press [MODE] to exit this sub-menu and return to the first sub-menu.
4. If there is any change to the existing selection, pressing the [Y/+] key will show “Save?” Then, press [Y/+] to accept or [N/-] to discard and return to the first sub-menu.

4.9 Exit Programming Mode

1. To exit programming mode from the first tier menu level (see Table 4.1), press the **[MODE]** key once.
Display shows an instantaneous reading of normal operation mode.
2. To exit programming mode from 2nd tier sub-menu level (see Table 4.2 - 4.6), press the **[MODE]** key twice.
3. To return to programming mode, press and hold down both the **[MODE]** and **[N/-]** keys for 3 seconds as described in Section 4.4.

5. COMPUTER INTERFACE

Each MultiRAE IR with a datalogging option is shipped with a software package, called ProRAE-Suite, and a serial computer interface cable.

This software package runs on any IBM compatible Personal Computer (PC) under Windows 95®, Windows® 98, Windows NT® 4.0, Windows ME and later environments. It allows the user to configure the MultiRAE IR through a user friendly interface and send the configuration information from the PC to the MultiRAE IR monitor. Collected data can also be extracted from the MultiRAE IR to the PC in order to perform data analysis, report generation or record keeping. Installation and operation of this software package is described in the following sections.

5.1 ProRAE-Suite Software Installation

ProRAE-Suite software package is supplied with the MultiRAE IR datalogging monitor. This software package is available on two 3.5" setup diskettes. To install the ProRAE-Suite software, insert the first setup diskette into the "A" or "B" floppy disk drive. Click the **Start** button on the taskbar to display the start menu, then click the **Run** from the start menu to display the **Run** dialog box. If the setup diskette is in disk drive A, type A:\Setup.exe in the **Open** field, as shown in Figure 5-1.



Figure 5-1 Run Dialog Box

Press the **Enter** key on the keyboard or click the **OK** button on the menu to start the setup process. If the user choose the default settings in every steps of the process, the ProRAE-Suite software package will be installed under the default directory: **C:\Program Files\RAE Systems Inc\ProRAE-Suite**. After the software is installed successfully, a new menu item **ProRAE-Suite** is added to

the **Programs** menu. To start the ProRAE-Suite software, click the **Start** button on the taskbar to display the **Start** menu, click the **Programs** menu item to display the **Programs** submenu, then click the **ProRAE-Suite** menu item to display the **ProRAE-Suite** submenu. There are two submenu items under the **ProRAE-Suite** submenu: **ProRAE-Suite** and **Readme**, as shown in Figure 5-2. Click the **ProRAE-Suite** submenu item to start the ProRAE-Suite software.

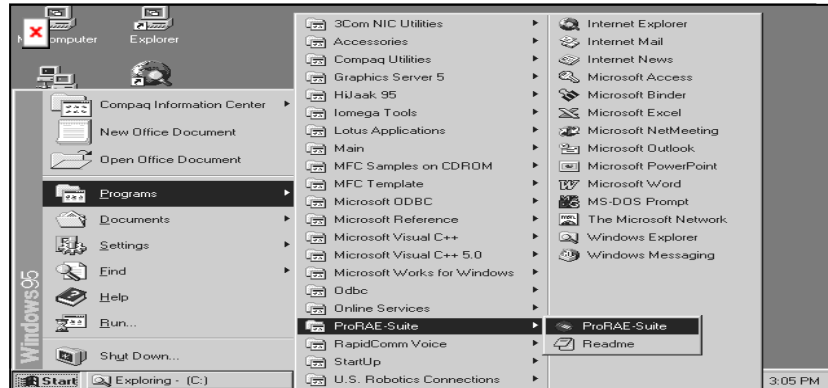

Figure 5-2 Start Menu

5.2 PC Connection

The basic kit of a MultiRAE IR datalogging monitor includes a serial interface cable. Connect the DB-9 connector side of the cable to the serial port of the PC, and connect another side of the cable to the MultiRAE IR monitor.

Turn on the power to the MultiRAE IR monitor. Press the **[MODE]** key several times until the LCD shows “Communicate with PC?” Press the **[Y/+]** key and the display shows “Monitor will Pause, OK?” Press **[Y/+]** key to confirm and the display shows “Ready...” to indicate that the MultiRAE IR monitor is ready for communication with PC. During the communication session, the PC will directly control the MultiRAE IR monitor through the serial link. There is no need for users to press any key on the MultiRAE IR monitor during the communication session.

If no data transfer has occurred within one minute, the MultiRAE IR monitor will return to instantaneous reading display.

<p>Note: Do not connect to the parallel port of the PC by mistake. The parallel port is usually a 25 pin female D connector on the back of the PC, the serial port is usually a 25 or 9 pin male D connector. If the serial port on the PC is a 25 pin connector, the user needs to use a 25 pin to 9 pin adapter in order to accept the serial cable.</p>
--

5.3 Starting ProRAE-Suite Software

To start the ProRAE-Suite software, click the **Start** button on the taskbar to display the **Start** menu, click **Programs -> ProRAE-Suite -> ProRAE-Suite** sub-menu item to start the ProRAE-Suite software. Figure 5-3 shows the main window of the ProRAE-Suite software.

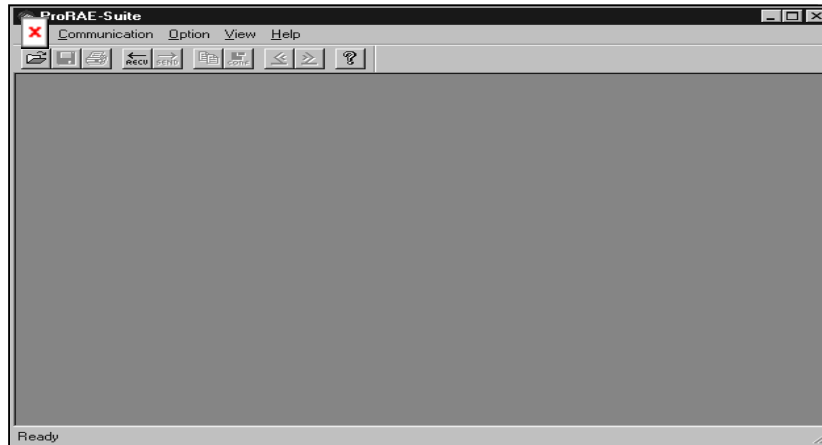

Figure 5-3 ProRAE-Suite Main Window

The functions of ProRAE-Suite software can be divided into three categories:

- 1) Configuration data category. This category includes editing the configuration data file, sending the configuration data to the MultiRAE IR monitor and receiving the configuration data from the MultiRAE IR monitor, etc.
- 2) Logged data category. This category includes receiving the logged data from the MultiRAE IR monitor, displaying the logged data in different format,

exporting the logged data to a tab delimited text file so that it can be read by the Microsoft Excel software, etc.

- 3) Upgrade category. This category includes upgrading the datalog feature of the MultiRAE IR monitor, and upgrading the firmware in the MultiRAE IR monitor.

There is a tool bar beneath the menu bar. The frequently used functions are represented in this tool bar in the form of a small icon. For example, the **Receive data** function in the **Communication** sub-menu is represented as a small arrow with the letters "RECV." When the mouse cursor (a small arrow) is positioned near each icon in the tool bar, a short text will also appear at the bottom of the Window to describe the function of this icon.

This tool bar allows users to invoke a function conveniently by clicking on the icon without going through the sub-menus.

5.4 Setup of Communication Port

It is necessary to setup the communication port in the ProRAE-Suite software so that the MultiRAE IR monitor can communicate with the PC correctly. Figure 5-4 shows the **Setup Port** dialog box. Choose the appropriate port according to the PC's serial port setup.

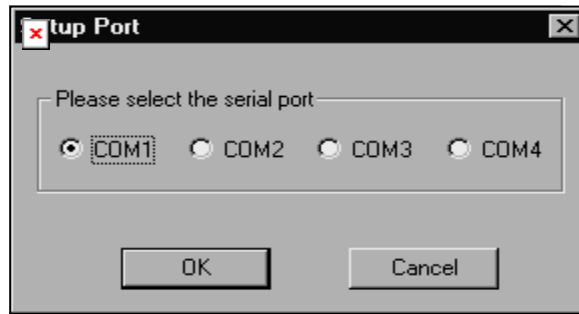

Figure 5-4 Setup Port Dialog

Note: In most PC's, there are two serial ports. Make sure that the serial port selected in the **Setup Port** dialog box matches the actual serial port connected to the MultiRAE IR monitor. The default serial port for ProRAE-Suite is COM1. If the incorrect serial port is selected, an error message of “error occur during serial port initialization” appears when a user tries to communicate between the PC and the MultiRAE IR monitor.

5.5 Processing the Configuration Data

The ProRAE-Suite software allows the user to edit the configuration data, send the configuration data to the MultiRAE IR, and receive the configuration data from the MultiRAE IR monitor. The following subsection describes the details of each operation.

5.5.1 Editing the Configuration Data

There are two different sources of the configuration files. One is loaded from the unit, the other is from a stored configuration file on the PC.

To load and review the monitor configuration: From the main menu of the ProRAE-Suite software, select the **Receive Configuration...** menu item from the **Communication** dropdown menu, then click **OK** if the unit is connected to the communication port and is ready.

To load a saved configuration file: From the main menu, select **Open** from the **File...** dropdown menu, a dialog box appears. Select the “Files of type:” to Config Files [*.cfg], as shown in Figure 5-5.

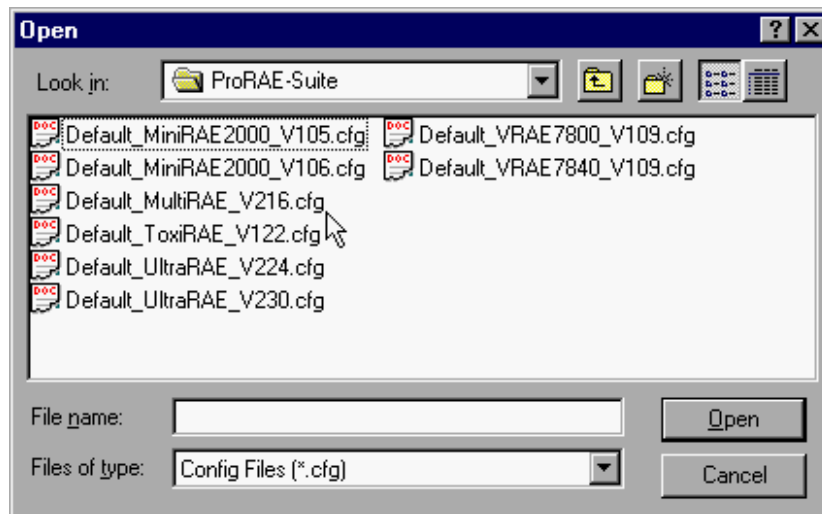

Figure 5-5 Open Dialog Box

There should be one or more configuration files in the file list. Each configuration file has a file extension of “.CFG”. There is one generic MultiRAE IR configuration supplied with ProRAE-Suite: **Default_MultiRAE_IR_V###.CFG**, where **###** is the version number of the configuration file. For example, **Default_MultiRAE_IR_V216.cfg** means this file is for MultiRAE IR monitor and its version is 2.16. Choose a configuration file by highlighting the file name and press the **Enter** key or click the **OK** button on the dialog box.

Once the configuration file is open, the configuration data is displayed in the newly opened client window, as shown in Figure 5-6.

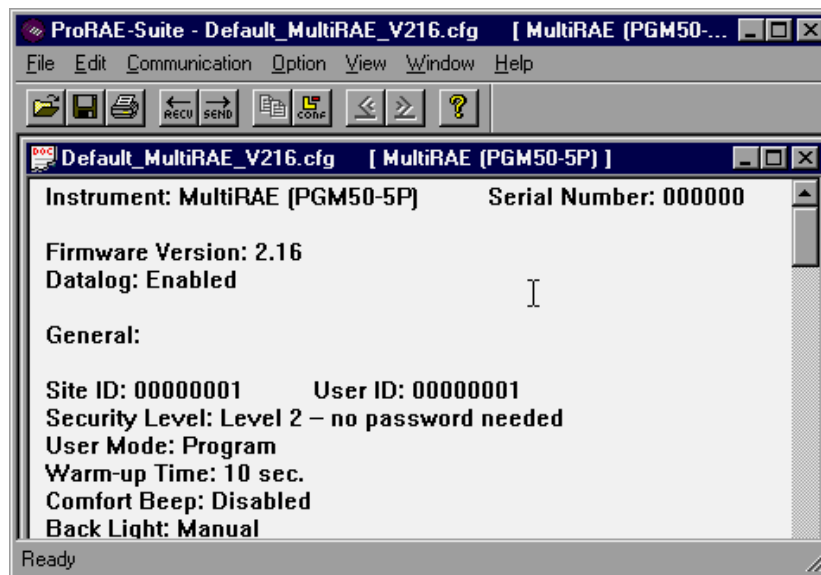

Figure 5-6 Displayed Configuration Data

To edit the opened configuration data file, click the **Edit -> Configuration** menu item or the **Configuration** toolbar button to open the **Edit Configuration File** dialog box, as shown in Figure 5-7.

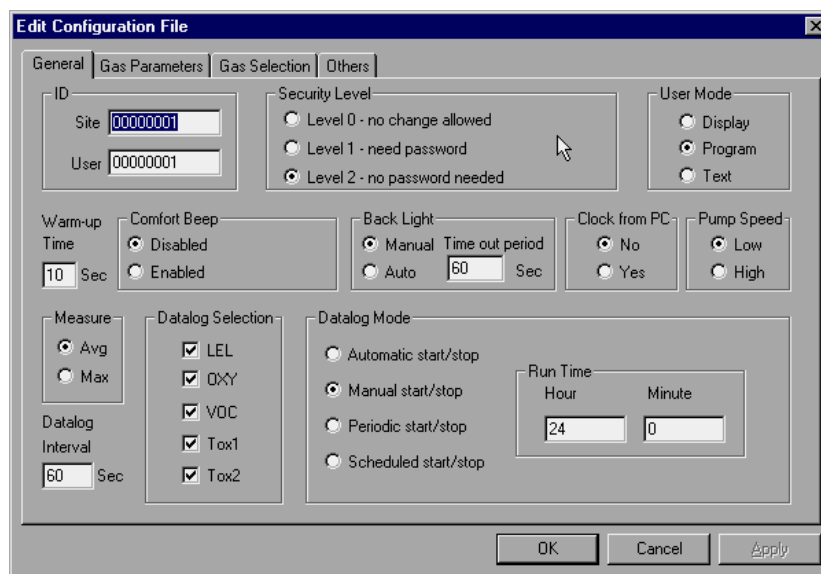

Figure 5-7 Edit Configuration File Dialog Box

The **Edit Configuration File** dialog box contains three tab pages: General, Gas Parameters and Gas Selection. To change a specific configuration setting, click the corresponding tab page header to bring that tab page to the front, then change the configuration setting on that tab page. When finished editing the configuration settings, click the **OK** button to close the **Edit Configuration File** dialog box. The new values of the configuration settings will be reflected in the client window.

Note: The VOC gas configuration settings apply only to monitors that are equipped with a PID.

The **General** tab page, which is shown in Figure 5-7, allows a user to change the general settings of the configuration data. The following is the description of each field in the **General** tab page of the **Edit Configuration File** dialog:

ID:

This section sets the identification that is used throughout the datalog process. Both editing fields, **Site** and **User**, can hold up to eight alphanumeric letters.

Security Level:

There are three levels of security. They are used to prevent unauthorized changes to monitor settings that are available in the programming menu.

Level 0 allows a user to enter the programming menu without password checking, but does not allow changes to alarm limits, real time clock, correction factor, or user and site information, etc. The user can still perform calibrations.

If **Level 1** is selected, a four digit password is required to enter the programming menu.

If **Level 2** is selected, the programming menu may be entered without restriction. Any changes made in the programming menu can be saved.

Password:

The four-digit password must be entered if Level 1 is selected as the security level or the monitor is in the **Text**

mode. Entry to the programming menu requires that this password be entered.

User mode:

In the **Text** mode, the monitor only displays the sensor name and an **OK** message during normal operation. In the **Display** mode, the user can view several readings in the normal operation, but cannot enter the programming menu. In the **Program** mode, the user can enter the programming mode to calibrate the monitor or change various setup in the monitor.

Warm-up Time:

This option allows the user to choose the warm-up time of the instrument, in seconds.

Comfort Beep:

Here the user can specify a time interval that the monitor beeps to remind the user that it is on. If zero is entered for the time interval, then the security beep feature is disabled.

Back Light:

This option allows the user to choose to turn on and off the LCD back light manually or automatically based on the ambient light sensor input. If **Manual** mode is selected, the user can also enter a time-out period so that the back light is turned off automatically after the specified time. If **Auto** is selected, the ambient light sensor automatically turns the backlight on and off.

Clock from PC:

This option allows the PC clock to be downloaded to the monitor.

Pump Speed:

This option allows selection of the high or low pump speed.

Measure:

The user can choose to record the average or peak (Max) reading of all the sensors during each datalog period.

Datalog Interval:

The datalog interval is the time (in seconds) after which each datalog sample is calculated and stored in memory.

Datalog Selection:

The user can enable datalogging for one or more sensors. This feature affects only the datalogging, not the displayed sensor readings.

Datalog Mode:

This may be set to either of four choices:

- With **Automatic start/stop**, the datalogging begins when the monitor is turned on and ends when it is turned off.
- With **Manual start/stop**, the datalog can begin by a series of key presses in the menu of normal operation. The maximum run time determines an automatic end to the datalog or it can be stopped manually.
- If **Periodic start /stop** (or daily) mode is chosen, the user must specify the start and stop hour and minute. The interval between start and stop is the period of time the monitor will datalog (at “data logging period” rate).

-- With **Scheduled start/stop**, all the entry boxes for year, month, day, hour and minute for both start and stop time must be entered to specify when the datalog is to occur.

Run Time:

If manual start/stop mode for datalogging is chosen, the user needs to specify a maximum run time. After the monitor has been on for the specified run time, datalogging will be turned off automatically.

Start Time and Stop Time:

If scheduled start/stop mode is chosen for datalogging, all entry boxes must be completed for start and stop year, month, day, hour and minute. The monitor must already be turned on. Then once the start date/time is reached, the monitor will start datalogging. When the stop date/time is reached, the datalogging will stop automatically. With periodic start/stop mode, the hours and minutes are used for the data log period to be run each day.

Figure 5-8 shows the **Gas Parameters** tab page which allows the user to change the gas parameters of the configuration data. The following is the description of each field in the **Gas Parameters** tab page of the **Edit Configuration File** dialog:

LEL Alarm Levels (%):

Here the user can specify the low alarm level (%) and high alarm level (%) for the LEL sensor.

OXY Alarm Levels (%):

Here the user can specify the low alarm level (%) and high alarm level (%) for OXY sensor.

The screenshot shows the 'Edit Configuration File' dialog box with the 'Gas Parameters' tab selected. The dialog is divided into several sections:

- LEL Alarm Levels (%):** Low: 10.0, High: 20.0
- OXY Alarm Levels (%):** Low: 19.5, High: 23.5
- VOC Alarm Levels (ppm):** STEL: 25.0, TWA: 10.0, Low: 50.0, High: 100.0
- Tox1 Alarm Levels (ppm):** STEL: 100.0, TWA: 35.0, Low: 35.0, High: 200.0
- Tox2 Alarm Levels (ppm):** STEL: 15.0, TWA: 10.0, Low: 10.0, High: 20.0
- Alarm Mode:** Auto Set, Latched
- Power On Zero:** Disabled, Enabled
- Calibration Span:** LEL (%): 50.0, OXY (%): 20.9, VOC (ppm): 100.0, Tox1 (ppm): 50.0, Tox2 (ppm): 25.0

Buttons at the bottom: OK, Cancel, Apply.

Figure 5-8 Gas Parameters Settings Tab Page

VOC Alarm Levels (ppm):

Enter the STEL alarm level (ppm), TWA alarm level (ppm), low alarm level (ppm) and high alarm level (ppm) for VOC sensor.

Tox1 Alarm Levels (ppm):

Enter the STEL alarm level (ppm), TWA alarm level (ppm), low alarm level (ppm) and high alarm level (ppm) for Tox1 sensor.

Tox2 Alarm Levels (ppm):

Enter the STEL alarm level (ppm), TWA alarm level (ppm), low alarm level (ppm) and high alarm level (ppm) for Tox2 sensor.

Alarm mode:

If **Auto** reset is chosen, the alarm will stop as soon as the alarm condition goes away. The alarm will remain on if the **Latched** option is chosen. To turn off a latched alarm, press [Y/+] key to acknowledge the alarm condition.

Power On Zero:

This option allows the monitor to perform a fresh air calibration automatically when the monitor is turned on. Care must be taken, when using this mode, to ensure that the monitor is in a fresh air environment when turned on.

Calibration Span:

The span gas concentrations for all sensors are set here.

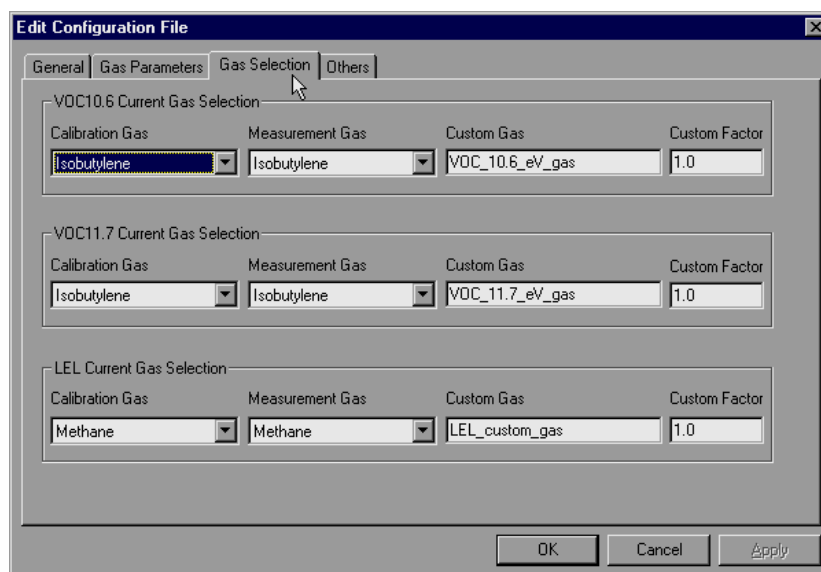

Figure 5-9 Gas Selection Settings Tab Page

Figure 5-9 shows the **Gas Selection** tab page. There are three sets of gases for correction factors that the user can choose: one for the LEL sensor, one for the PID sensor with 10.6 eV lamp and other one for the PID sensor with the 11.7 eV lamp.

In each case the user can choose one gas from the **Calibration Gas** list box for calibration and another gas from the **Measurement Gas** list box for measurement. Each list contains about 20 to 40 gases. Scroll the list using the up or down arrow until the desired gas name is shown. Press **Enter** key to select the gas. It is also possible to enter a custom gas name (up to 16 characters long) and a custom correction factor.

In the **Others** tab, the user can put in a power-on-customized name. The name will be displayed when the unit is powered on. The user can also enable or disable the on-line printing option.

OK/Cancel:

When the configuration changes are completed, click on the **OK** button to save the configuration and return to the client window. Click on **Cancel** button to abort the configuration changes.

5.5.2 Sending Configuration to Monitor

After the configuration data is loaded into the ProRAE-Suite software, the user can send the configuration settings to the MultiRAE IR monitor. To send the configuration settings to the instrument, click **Communication->Send Config** menu item or click the send toolbar icon (right arrow with “Send” letters), a message box will appear to remind the user to connect the instrument to the PC through the serial port. After making sure that the instrument is connected to the PC, click the **OK** button to start the data transfer.

After the configuration information is sent successfully, a message box will appear to indicate that the sending configuration process is completed. Click the **OK** button to close the message box.

If the communication is not successful, an error message indicating that there is no response from the instrument will appear. Check the cable to make sure that the connectors on both ends of the cable are securely seated in the sockets. Try to send the information again. If the error message still appears after repeated attempts, call an authorized service center for help.

5.5.3 Saving Configuration Data

In order to save the configuration information for future use, click **File->Save** or **File->Save As**

6. THEORY OF OPERATION

The MultiRAE IR monitor uses one to five different sensors to measure a variety of gases. A newly developed Non-dispersive infrared (NDIR) sensor measures CO₂ (see Figure 6-1). Infrared light is shone through the gas sample and the amount absorbed by the CO₂ is proportional to its concentration. The patented PID sensor uses an electrodeless discharge UV lamp as a high energy photon source to ionize a broad range of organic vapors (VOCs). The resultant electrical current is proportional to the VOC concentration. An interchangeable electrochemical toxic gas sensor can be installed to measure one of several inorganic toxic gases. A catalytic bead sensor is used to measure combustible gases. The bead is heated and any organic vapors combust to heat the bead further, causing a change in resistance proportional to the gas concentration. Another electrochemical sensor measures oxygen. Another electrochemical sensor measures oxygen.

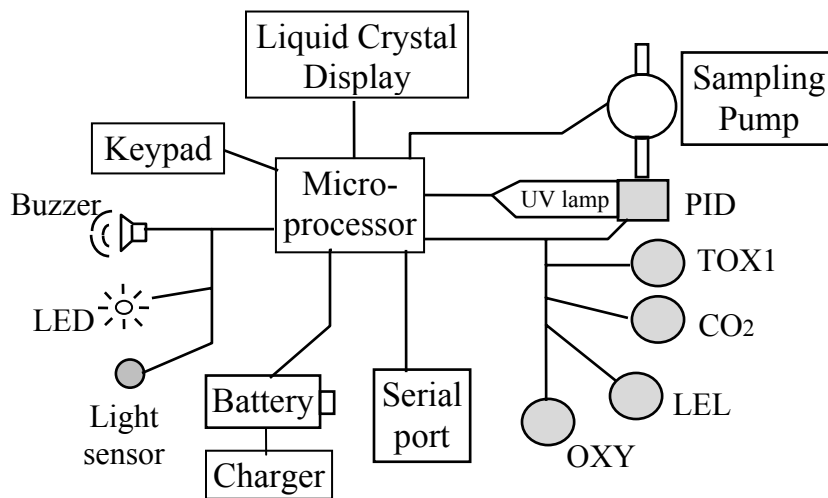

Figure 6-1 Block Diagram of MultiRAE IR Monitor

The PID sensor for the MultiRAE IR monitor is constructed as a small cavity in front of the UV lamp. The other sensors are mounted next to the PID sensor. A diaphragm pump is installed inside the monitor to draw the air sample into the sensor manifold and then distribute it to all sensors.

A single chip microcomputer is used to control the operation of the alarm buzzer, LED, pump and light sensor. It measures the sensor readings and calculates the gas concentrations based on calibration to known standard gases. The data are stored in non-volatile memory so that they can be sent to a PC for record keeping. RS-232 transceivers provide a serial interface between the monitor and the serial port of a PC. A 2-line by 16-character LCD display is used to show the readings. The user interacts with the monitor through three keys on the front panel keypad. A rechargeable Li-ion battery or a set of four disposable AA alkaline batteries powers the monitor.

<p>NOTE: The printed circuit board is connected to the battery pack even if the power is turned off. Therefore, it is very important to disconnect the battery pack before servicing or replacing sensors or any components inside the monitor. Severe damage to the printed circuit board may occur if the battery pack is not disconnected before servicing the unit.</p>
--

7 MAINTENANCE

As shown in Figure 7-1, the major maintenance items of MultiRAE IR are:

- Battery pack
- Sensor modules
- PID lamp
- Sampling pump

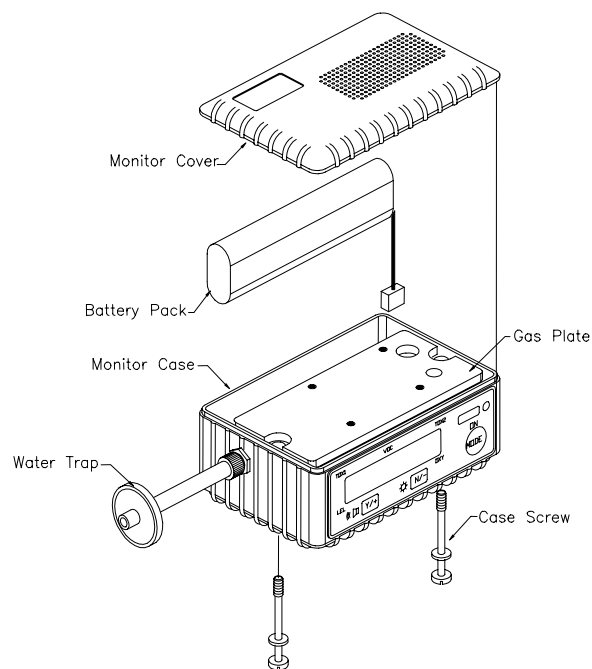

Figure 7-1. Main Components of the MultiRAE IR

7.1. Battery Replacement

When the display shows a flashing message “Bat”, the battery requires recharging. The battery may be replaced in the field (in area known to be non-hazardous) if required. It is recommended to recharge the MultiRAE IR monitor upon returning from fieldwork. A fully charged battery powers a MultiRAE IR monitor for 12 hours continuous operation. The charging time is about 10 hours for a fully discharged battery. The built-in charging circuit is controlled by two-step constant voltage / constant current charging to prevent over-charging.

WARNING:

To reduce the risk of ignition of hazardous atmospheres, recharge battery only in area known to be non-hazardous. Remove and replace battery only in area known to be non-hazardous.

Replacing and Recharging Battery Pack

1. Turn off the MultiRAE IR.
2. Referring to Figure 5-1, unscrew the two captured case screws from the bottom of the monitor case and remove the cover.
3. Unplug the battery from the battery jack, which is connected to the PC board of the MultiRAE IR.
4. Connect the battery pack to the DC jack on an external charging station (optional) for charging.
5. Insert a fully charged spare battery pack or a new pack.
6. Ensure the battery plug is securely connected.
7. Close the cover and tighten the screws.

Note: The MultiRAE IR is designed for use with either Li-ion rechargeable batteries or alkaline disposable batteries. The NiCd rechargeable batteries used in the MultiRAE PLUS cannot be used in the MultiRAE IR.

Replacing Alkaline Battery Adapter

1. Insert four fresh AA size alkaline batteries into the alkaline battery adapter. Make sure that the polarity of the battery is correct.
2. Follow the same procedure as described above to replace the battery adapter.

Note: The internal charging circuit is designed to recognize and prevent charging of alkaline batteries when they are installed.

7.2. Sensor Replacement

The toxic, combustible and oxygen sensors all have an expected operating life. Under normal operating condition, most sensors will lose their original sensitivity after the expected operating life and will need to be replaced.

Each sensor module in MultiRAE IR includes a non-volatile memory, which records the manufacturing date of the sensor. In the diagnostic mode, the microprocessor checks the date code and displays the expiration date of each sensor. It is suggested that the sensor be replaced when the current date exceeds the expiration date, as the sensor may be nearing the end of its useful operating life.

Sensor Replacement Procedure

The carbon dioxide, oxygen and combustible sensors each have their unique sensor sockets in the MultiRAE IR monitor. The toxic sensor socket in the MultiRAE IR monitor allows users to plug in any of the sensors selected from the series of toxic sensors offered by RAE Systems Inc.

1. Turn off the power.
2. Referring to Figure 7-1, open the monitor cover by unscrewing the two captured screws from the bottom of the monitor case. **Disconnect the battery pack.**

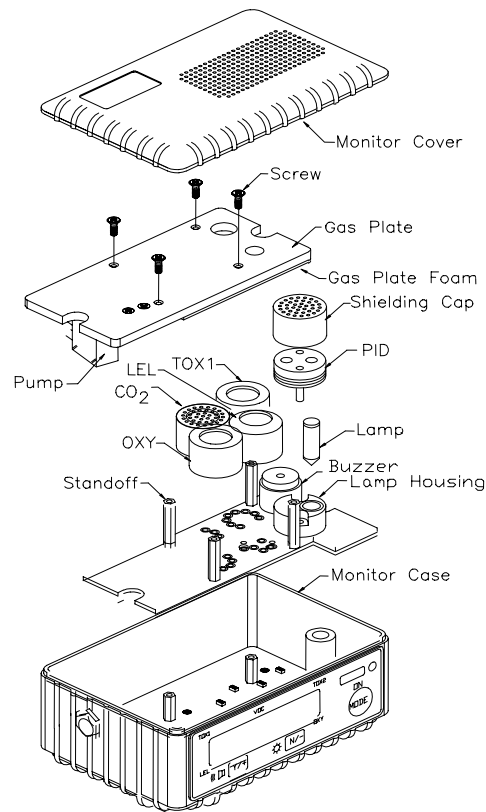

Figure 7-2 Sensor Assembly of MultiRAE IR

3. Referring to Figure 7-2, carefully unscrew four No. 2 screws that hold down the gas piping plate to the analog PCB and sensors. Remove the gas piping plate.
4. Referring to Figure 5-2, identify the location of a specific sensor and remove the sensor by gently pulling the sensor upward.

5. Plug a new sensor into the empty sensor socket. Make sure that black line on the sensor label is lined up with the white mark on the PCB and the sensor pins are aligned with the socket before pushing down the sensor.
6. Replace the gas piping plate and tighten the four screws to hold down the sensors. Re-connect the battery pack. Replace the monitor cover.
7. Turn on the power of the MultiRAE IR. The microprocessor will automatically recognize the sensors installed and configure the monitor accordingly.

Special Bias Voltage for Toxic Sensors:

The NO and NH₃ toxic sensors require a special 300 mV bias voltage to operate, controlled by a dip switch or pin jumper located on the analog PCB next to the PID sensor. When a biased toxic sensor is plugged into the Tox1 position, it is necessary to turn the dip switch or move the jumper to the “ON” position to enable the bias voltage. During power on sequence, the microprocessor will check the sensor ID and the bias voltage. If the bias voltage is not switched on when an NO or NH₃ sensor is installed, an error message will be displayed.

7.3. Sensor Cleaning/Replacement

This section only applies to a monitor that is equipped with the PID option. During the course of normal operation, a chemical film may build up inside the PID sensor module and the UV lamp. The rate at which a film develops depends on the type and concentration of the vapors being sampled. As a guide, it is recommended to clean the PID sensor module and lamp only when the PID is malfunctioning.

The sensor module is made of several components and is attached to the lamp housing unit as shown in Figure 7-2. If the lamp does not turn on, the monitor will display an error message of “Lamp” to indicate cleaning or replacing of the lamp is required. Periodic cleaning of the lamp window will also remove film deposits and restore lamp sensitivity. **Care must be exercised when cleaning the window surface so that it will not be damaged.**

1. Turn off the power.
2. Referring to Figure 7-1, open the monitor cover by unscrewing the two case screws from the bottom of the monitor case. **Disconnect the battery pack.**
3. Referring to Figure 7-2, carefully unscrew four No. 2 screws that hold down the gas piping plate to the analog PCB and sensors. Remove the gas piping plate.

4. Remove the shielding cap for the PID sensor. Gently pull out the PID sensor. Note the sensor is made of Teflon and stainless steel material.
5. Place the entire PID sensor into GC grade methanol. It is highly recommended that an ultrasound bath to be used to clean the sensor for at least 10 minutes. Then dry the sensor thoroughly.
6. If the lamp is operational, use a cotton swab to clean the flat window surface with GC grade methanol. If the lamp does not turn on, remove the UV lamp.
7. Install a new lamp, avoiding contact with the flat window surface.
8. Reinstall the PID sensor. Install the shielding cap.
9. Referring to Figure 7-2, install the gas piping plate and tighten the four screws to hold down the sensors. Reconnect the battery pack. Install the monitor cover.

7.4. PID Lamp Care

The UV lamp is made of a glass envelope and a UV window on one end of the envelope. The inside of the lamp is filled with low pressure gases. To turn on the lamp, a high voltage electric field is applied from the outside of the glass envelope. The molecules inside the lamp are ionized and produce a glow discharge to generate the UV light.

If the UV lamp has not been used for a long period of time (> 1 month), it may be slightly harder to turn on. If such a condition occurs, an error message “Lamp” will appear in the monitor display during the power on sequence. This phenomenon is more significant in 0.25” UV lamps used in MultiRAE IR products, because of the relatively small lamp size.

To solve this problem, simply turn on and off the monitor a few times and the lamp should turn on. After the UV lamp is turned on for the first time, it should be easier to turn on the UV lamp next time.

The MultiRAE IR has a built-in sensing mechanism to monitor the status of the UV lamp. If the UV lamp is not on, the error message “Lamp” will be displayed. It is possible that the UV lamp is actually on when the lamp error message appears. When the UV lamp becomes old, changed, or the configuration file has been totally overwritten, the threshold level to determine lamp failure may be wrong and cause a false alarm. To eliminate such a possibility, simply apply some VOC by putting a felt-tip

marker close to the inlet of the MultiRAE and see if the VOC raw count goes up. If the UV lamp is on while the error message persists, then it is necessary to adjust the lamp threshold. Please refer to Chapter 8 on adjusting the threshold level for the UV lamp.

If chemical liquid or dust has been sucked into the unit, clean the lamp window surface by wiping it with anhydrous methanol using a cotton swab. Rub in a circular motion at moderate pressure. After cleaning, hold the lamp up to the light at an angle to detect any remaining film. Repeat the process until the lamp window is clean.

Never touch the window surface with fingers or anything that may leave a film.

(CAUTION: Water will degrade window surfaces, especially the 11.7 eV lamp window)

7.5. Sampling Pump Replacement

The gas sample is drawn into the instrument with a diaphragm pump. When approaching the end of the pump life, it will consume more energy and the flow will drop significantly. When this occurs, it is necessary to replace the pump.

1. Turn off power to the MultiRAE IR.
2. Referring to Figure 7-2, open the monitor cover, **disconnect the battery pack**, carefully unscrew four No. 2 screws that hold down the gas piping plate to the analog PCB and sensors. Remove the gas piping plate.
3. Carefully loosen the connector. Unscrew the two screws that hold the pump assembly to the gas plate. Disconnect the Tygon tubing that connects the pump to the gas inlet port.
4. Install a new pump assembly. Connect the Tygon tubing to the gas inlet port. Solder the pump wire and screw down the pump assembly to the analog PCB.
5. Referring to Figure 7-2, replace the gas piping plate and tighten the four screws to hold down the sensors. Re-connect the battery pack. Replace the monitor cover.

8. TROUBLESHOOTING

To aid the user in diagnosing the monitor, a special diagnostic mode can be used to display critical, low level parameters. Section 8.1 describes the operation of the diagnostic mode. Section 8.2 summarizes the frequently encountered problems and suggested solutions. With these aids, it is often possible to narrow down the problem to one or two areas and correct it without having to return the monitor for repair.

WARNING: The diagnostic mode allows the user to set several low-level parameters, which are very critical to the operation of the monitor. Extra care should be taken when setting these low-level parameters. If the user are not familiar with these parameters and set them incorrectly, it may cause the monitor to shut down or malfunction. Only qualified personnel should use the diagnostic mode.

7.1. Special Diagnostic Mode

To place the monitor into the special diagnostic mode, first turn the monitor off. Next push and hold the [Y/+] key, and while still holding the [Y/+] key, also push and hold the [MODE] key for at least two seconds (until the beep stops). After the required delay, release both keys, and the monitor will go through the normal start-up display sequence and display a “Diagnostic mode” message. At the end of the special mode start-up, the display shows 1 to 5 numbers with a message “Raw.” These numbers are raw sensor readings without calibration.

Other critical parameters of the monitor are available as shown in Table 8.1. They can be reached by pressing the [MODE] key repeatedly until the desired parameter is displayed.

Once started in Diagnostic Mode, the unit can be toggled between normal and diagnostic modes by holding down the [Y/+] and [MODE] keys. It is also possible to enter all programming functions directly from Diagnostic Mode by holding down the [N/-] and [MODE] keys.

Table

8.1

Key Action	Display
	Show raw readings
[MODE]	Show sensor name(s)
[MODE]	PID lamp current Adjust failure threshold
[MODE]	Show battery type and Tox1 bias
[MODE]	Show Ch. A & B of CO ₂ sensor
[MODE]	Adjust LCD contrast
[MODE]	Set LEL power on/off
[MODE]	Show date, clock, battery voltage and temperature
[MODE]	Show LEL & OXY sensor expiration dates
[MODE]	Show TOX1 & CO ₂ sensor expiration dates
[MODE]	Adjust pump stall threshold
[MODE]	Adjust back light on/off threshold
[MODE]	Show serial number and toggle pump speed
[MODE]	Show battery duration time
[MODE]	Communicate with PC?

Note: The lamp failure and PID sensor range displays only apply to monitors that are equipped with a PID option.

Below is a brief description of each diagnostic display and how to interpret the displayed values:

1) Raw Sensor Readings

The raw sensor readings provide a quick diagnose on the response and the sensitivity of each sensor. When zero gas (fresh clean air) is applied, the raw sensor readings typically should be between 500 to 3500 for the CO₂ sensor, 200 to 700 for the toxic and VOC sensors, between 100 to 1500 for the LEL sensor and between 800 to 2300 for the oxygen sensor. If the raw reading is outside these ranges when zero gas is applied, the sensor or the electronics may be defective.

When a specific gas is applied to the monitor, the corresponding sensor should respond and the raw reading should increase or decrease. If the reading of the corresponding sensor does not change when the specific gas is applied, then the sensor may be defective.

TOX1	VOC	TOX2
365	360	
	2373	
530	RAW	1879
LEL		OXY

2) Sensor Name

All the toxic, oxygen, CO₂ and LEL sensors have a non-volatile memory that contains the sensor identification and other vital information, such as manufacturing date, expected operating life, etc. If a sensor is programmed and installed properly in the monitor, the sensor name should be displayed. If the sensor name does not show up in the display, then the sensor may not be programmed properly or may be defective.

3) Adjust Lamp Failure Threshold

This diagnostic menu only applies to the monitor which is equipped with a PID detector option. This display can be used to calibrate the PID lamp failure threshold. If the lamp appears to be good but in normal operation a lamp failure message (i.e. "Lamp") is displayed, the lamp failure level may be set too high. This level can be adjusted by using the following steps:

1. Turn the monitor off.
2. Remove the UV lamp of the PID sensor, then replace the sensor and cover.
3. Turn on the monitor in the special diagnostic mode.
4. Press the **[MODE]** key until "Lamp = xxx, Fail = yyy +/-" is display. The reading "xxx" is the lamp current reading when the lamp is off. The value "yyy" is the threshold value, which determines when does the lamp fail.
5. Push the **[Y/+]** or **[N/-]** key to increase or decrease the threshold value "yyy" until it is about 10 counts above the "xxx" value. This will optimally set the lamp failure threshold. Press **[MODE]** key to exit this display. If the threshold value is changed, a message "Save new lamp threshold?" will appear. Press **[Y/+]** to confirm the change, **[N/-]** or **[MODE]** key to abandon the changes.
6. Turn the monitor off and replace the lamp.

7. Turn on the monitor in diagnostic mode again and press the [MODE] key until “Lamp = xxx, Fail = yyy +/-” is display. This time, the reading “xxx” is the lamp current reading when the lamp is on and it should be higher than the threshold value “yyy” by at least 15-20 counts. If not, the lamp may be defective or very weak. In most cases lamp failure threshold adjust is not required, in which case the user should press [MODE] key to exit this display.

4) Battery Type and Bias Display

For some toxic sensors (such as nitric oxide or ammonia sensor), a bias voltage of a few hundred millivolts is required for the sensor to function properly. In the MultiRAE IR monitor, the user needs to manually switch on the bias voltage supply located on the analog PCB (see Section 7.2 for details). This may alternately be a jumper, where the jumper position should follow the board marking – On or Off. For this test to work, a nitric oxide or ammonia sensor must be installed in the toxic socket. If the bias voltage is switched to ON position, the bias reading should be below 182, otherwise the bias supply may be defective.

The MultiRAE IR monitor can be powered by either a rechargeable Li-ion battery pack or an alkaline battery adapter. This display also shows the type of battery that is installed in the monitor.

5) Show Ch.A and Ch.B Range of CO₂ Sensor

This diagnostic menu only applies to monitors that are equipped with a CO₂ sensor option. The CO₂ sensor output is connected to two amplifiers. Channel A is for the

CO₂ signal and Channel B is for the reference. Raw outputs of both amplifiers are displayed. When zero gas is applied, Channel A should read a lower value, while Channel B should give almost no change. When CO₂ gas is applied, Channel A should increase, while Channel B should again show little or no change.

6) Adjust LCD Contrast

This display allows the user to adjust the LCD contrast. Press [Y/+] to increase the contrast and [N/-] key to decrease the contrast. The bar graph shows the current LCD contrast setting. If the display appears having dark lines, press [Y/-] key several times should see a more clear display.

7) Check LEL Power ON/OFF

This display shows the present condition of the LEL sensor power and raw reading. The top display shows the instantaneous reading of raw counts from the LEL sensor. The bottom line shows if the LEL sensor is powered. By pressing [N/-] key the power can be turned off. The [Y/+] key turns powers to the LEL on.

8) Show Clock, Date, Battery, and Temperature

This display shows the real time clock, battery voltage in raw count and temperature sensor reading.

9) Sensor Expiration Date

This display shows the expiration date (month and year) of all the installed sensors in the MultiRAE IR monitor. The expiration date is calculated based on the manufacturing date and expected life of each sensor which were stored inside each sensor when it was fabricated in the factory. If

the current date exceeds the expiration date of any sensor, the performance of the given sensor can no longer be guaranteed. It is strongly recommended that the user replace the sensor immediately to ensure proper operation of the sensor.

10) Adjust Pump Stall Threshold

This display can be used to calibrate the pump stall threshold. If the gas inlet is blocked but the pump does not shut down, or the pump shut down too easily with a slight blockage to the gas inlet, then the pump stall threshold value may be set too high or too low. Use the following steps to adjust the pump stall threshold.

1. The maximum and average pump current is displayed on the first row: "Pump = xxx/zzz." The current pump stall value is displayed on the second row: "Stall = yyy +/-." The typical maximum pump current without any blockage should be between 20 – 35 when the speed is set to be "low" and the water trap filter is installed. The typical stall value should be higher than the "un-blocked" pump current by at least 5-8 counts.
2. The user can block the gas inlet for about ten seconds and watch the pump current reading. The stall threshold should set to be the average of the idle reading and the block reading. That is: $\text{Stall} = (\text{Idle} + \text{Block}) / 2$. The readings to be used in the calculation are maximum pump current readings at the "xxx" location of the unit.
3. Use [Y/+] or [N/-] key to increase or decrease the stall value until it is the average of the idle reading and the block reading. Press [MODE] key to exit this display. If the threshold value is changed, a message "Save new

stall threshold?” will appear. Press [Y/+] to confirm the change, [N/-] or [MODE] key to abandon the changes.

4. The pump stall threshold should be re-adjusted if the pump speed is switched to “low” or “high,” or water trap filter changed, or the firmware configuration has been totally refreshed.

11) Check Back Light Threshold

This display can be used to adjust the LCD back light turn on and off threshold. Verify that the threshold is 100 which will fit almost all of the situation.

12) Serial Number and Pump Toggle

This display shows the unit’s serial number. If a pump is installed and pump speed control circuit available, the display “Pump=Low/(High)” may be toggled by pressing the [N/-] key. Note that changes made here are only for testing the pump condition and do not become saved in the nonvolatile memory (see Section 4.7 to update the pump speed setting).

13) Display Battery Duration Time

The display shows the run time of the last time the unit powered itself off due to a low battery. It is useful for the battery life testing.

14) Communicate with PC?

This display give the option of communicate with the PC for upload or download activity.

7.2. Troubleshooting Table

Table 8.2

Problem	Possible Reasons & Solutions
Cannot turn on power after charging the battery	<p>Reasons: Discharged battery. Defective battery. Microcomputer hang-up.</p> <p>Solutions: Charge or replace battery. Disconnect then connect battery to reset computer.</p>
No LED or LCD back light	<p>Reasons: Defective LED or LCD back light.</p> <p>Solutions: Call authorized service center.</p>
Lost password	<p>Solutions: Ask the service center for help.</p>
Buzzer inoperative	<p>Reasons: Bad buzzer.</p> <p>Solutions: Call authorized service center.</p>

TROUBLESHOOTING

Problem	Possible Reasons & Solutions
Reading abnormally high	<p>Reasons: Wrong calibration data. Dirty PID sensor module. Dirty water trap filter. Excessive moisture and water condensation.</p> <p>Solutions: Re-calibrate with gas. Clean PID sensor module. Replace water trap filter. Blow dry the sensor module.</p>
“Lamp” message during operation	<p>Reasons: Wrong threshold. Dirty PID sensor. Weak or defective PID lamp.</p> <p>Solutions: Adjust the lamp threshold. Clean PID sensor. Replace PID lamp.</p>
Reading abnormally low	<p>Reasons: Incorrect calibration. Low sensitivity to the specific gas.</p> <p>Solutions: Calibrate the monitor. Replace sensor.</p>

TROUBLESHOOTING

Problem	Possible Reasons & Solutions
Read a small background value when there is no detectable gas.	<p>Reasons: Sensor zero drifted. Battery had been disconnected or the sensor was newly plugged in.</p> <p>Solutions: Do fresh air calibration (see Section 4.4.1) Wait for reading to stabilize.</p>
Reading jumping around randomly	<p>Reasons: Incorrect gas calibration. Low sensitivity to cal gas.</p> <p>Solutions: Calibrate the sensor. Use different cal gas.</p>
Cannot turn off monitor or corrupted characters in LCD display	<p>Reasons: Microprocessor hang-up.</p> <p>Solutions: Disconnect and re-connect battery to reset computer. Call authorized service center.</p>
Calibration error message	<p>Reasons: No or low standard gas input. Sensor failure.</p> <p>Solutions: Make sure standard gas flows into monitor and concentraion is high enough. Clean or replace sensor.</p>

TROUBLESHOOTING

Problem	Possible Reasons & Solutions
“Bat” message in operation	<p>Reasons: Discharged battery.</p> <p>Solutions: Recharge battery.</p>
“Voltage too high message” in charge mode	<p>Reasons: Battery fuse blown or wrong. AC adapter or AC adapter does not fully plug in.</p> <p>Solutions: Check battery and adapter. Detach and plug in the adapter again.</p>
Full scale measurement in humid air	<p>Reasons: Dirty or wet sensor.</p> <p>Solutions: Clean and dry sensor. Replace water trap filter.</p>
Full scale VOC reading in humid air	<p>Reasons: Dirty, wet or damaged PID sensor.</p> <p>Solutions: Clean, dry or replace sensor. Replace water trap filter.</p>
VOC Reading saturates at certain level	<p>Reasons: Dirty PID sensor module. Weak PID lamp. Gas conc. too high</p> <p>Solutions: Clean lamp / sensor module. Replace lamp. Replace filter. Use dilution fitting or lower conc. sample</p>

QUICK REFERENCE GUIDE

DISPLAY MODE

Display Instantaneous Readings	[N]+[MODE] for 3 seconds: Security level=0 or Display Mode: No Action Security level=1 or Text Mode: Password check Wrong password: Back to instantaneous display Correct password: Enter Programming menu. [N]: Toggle back light [Y]: Test alarm/stop alarm
[M]	
Display Sensor names	
[M]	
Display Peak values	
[M]	
Display Minimum values	
[M]	
Display STEL values	
[M]	
Display TWA values	
[M]	
Display Battery voltage	
[M]	
Print Reading	
[M]	
Configured for Manual datalog?	yes: Start/Stop Datalog [Y]: Start or Stop Datalog [M]: Go to "Display LEL gas name" no: Display Datalog mode
[M]	
Display LEL gas name (if sensor is present)	
[M]	
Display VOC gas name (if sensor is present)	
[M]	
Communicate with PC?	[Y]: Monitor will pause OK? [Y]: Ready... [N]: Return to Instantaneous display
[M] or [N]	
Return to Instantaneous display	

PROGRAMMING MODE

Press [N] and [MODE] together for 3 seconds to enter, [Mode] to return

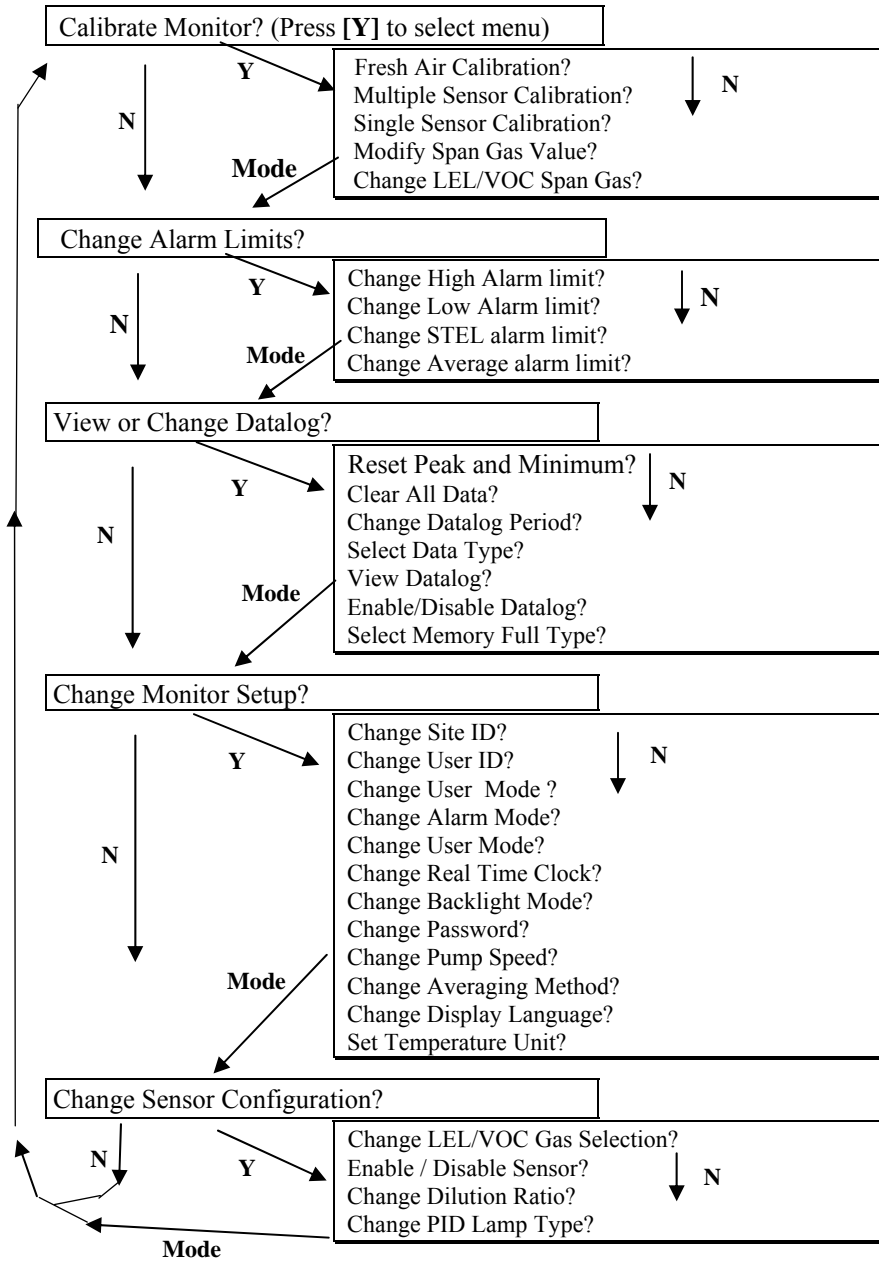

CORRECTION FACTORS

A partial list of correction factors for a number of commonly used compounds for the LEL sensor, 10.6 eV and 11.7 eV PID sensors is as follows (refer to TN-106 and TN-156 at www.raesystems.com for complete lists of correction factors):

Table B.1 **CF for PID & LEL Sensors**

Compound	10.6	11.7	LEL
Acetaldehyde	5.5		1.8
Acetic acid	14	2.5	3.4
Acetone	1.1		2.2
Acrylic acid	12	2.0	
Acrylonitrile		1.2	
Allyl alcohol	2.4	1.7	
Ammonia	9.7	5.7	0.79
Benzene	0.53		2.5
Butadiene	1.0		2.6
Butane, n-			2.0
Butyl acetate, n-	2.6		
Butyl acrylate, n-	1.6	0.61	
Carbon disulfide	1.2		7.2
Carbon monoxide			1.25
Chlorine		1.0	
Cyclohexane	1.4		2.5
Cyclohexanone	1.0		
Dichloroethane, 1,2-		0.6	
Dichloroethene, t-1,2-	0.45	0.34	
Dichloromethane		1.0	1.0

APPENDIX B

Compound	10.6	11.7	LEL
Diesel Fuel	0.66	0.35	
Diethylamine	0.97		
Dimethylhydrazine, 1,1-	0.78	0.83	
Epichlorohydrin	10		
Ethanol	12		1.7
Ethene	10		1.5
Ethyl acetate	4.6		2.6
Ethyl acrylate	2.4	1.0	
Ethyl benzene	0.52		2.8
Ethyl ether	1.1		2.3
Ethyl hexyl acrylate, 2-	1.1	0.48	
Ethyl sulfide	0.51		
Gasoline vapors	0.85		
Gasoline, whole	1.0	0.47	2.2
Heptane, n-	2.6		2.7
Hexamethyldisilazane	0.24	0.19	
Hexane, n-	4.3	0.5	2.4
Hydrazine	2.6	2.1	
Hydrogen			1.2
Hydrogen sulfide	4.1		2.3
Isobutane	120	1.1	1.8
Isobutene	1.00	1.00	2.0
Isobutyl acrylate	1.5	0.60	
Isopropanol	6.0		2.6
Jet fuel JP-4	0.99	0.42	
Jet fuel JP-5	0.6	0.46	
Jet fuel JP-8	0.6	0.32	
Methane			1.0
Methanol		2.5	1.5
Methyl acrylate	3.7	1.2	
Methyl ethyl ketone	0.86		2.6
Methyl isobutyl ketone	1.2		

APPENDIX B

Compound	10.6	11.7	LEL
Methyl methacrylate	1.4		
Methyl t-butyl ether	0.91		
Nitric oxide	5.2	2.8	
Octane, n-	1.8		2.9
Pentane			2.2
Perchloroethene	0.58		
Pinene, a-	0.31		
Pinene, b-	0.37		
Propane		1.6	1.9
Propene	1.7		1.8
Styrene	0.42		
Tetrahydrofuran	1.8		
Toluene	0.5		2.5
Trichloroethane, 1,1,1-		0.98	
Trichloroethene	0.52		
Vinyl chloride	2.0	0.64	1.8
Xylene, m-	0.43		2.7
Xylene, o-	0.59		3.0
Xylene, p-	0.45	0.62	2.8

* NR = No Response. Blank space = no data

For more data see Technical Notes 106 (PID) and 156 (LEL)

The VOC correction factors in Table B.1 are measured relative to isobutylene gas and LEL correction factors are measured relative to methane gas. All measurements are at <5% relative humidity and 25°C, typically at 50-100 ppm for VOC and 20-80% LEL for LEL. The factors may change at higher concentration or different temperature and humidity conditions. The factors are to be multiplied by the reading to obtain the actual concentration or % LEL of the gas. If the correction factor of a gas is <1.0, then the sensitivity to the gas is higher than that of isobutylene (VOC) or methane (LEL).

MULTIRAE DATA CONVERSION TO EXCEL®

The MultiRAE IR multi-gas monitor has a built-in 20,000 point datalogger that, in conjunction with the ProRAE-Suite software, provides data that can be converted into other application programs such as Microsoft Excel® for further data manipulation or graphing.

To convert the data file into Excel®, and to facilitate easier data manipulation, follow these procedures:

1. Export the event data to a tab delimited text file, as described in Section 5.6.6: **Export the displayed data to a text file**. Assume we have just export the event data to a file called TextEvent.txt in C:. To convert that file to a MS-Excel file, open the MS-Excel software, as shown in Figure C-1.

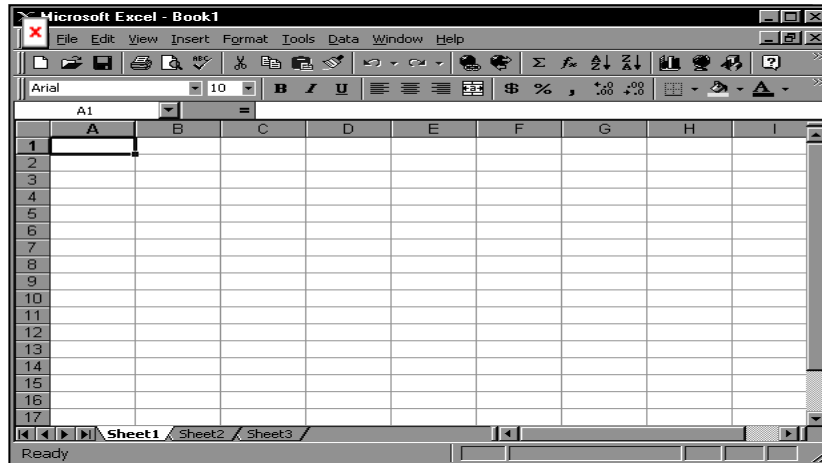
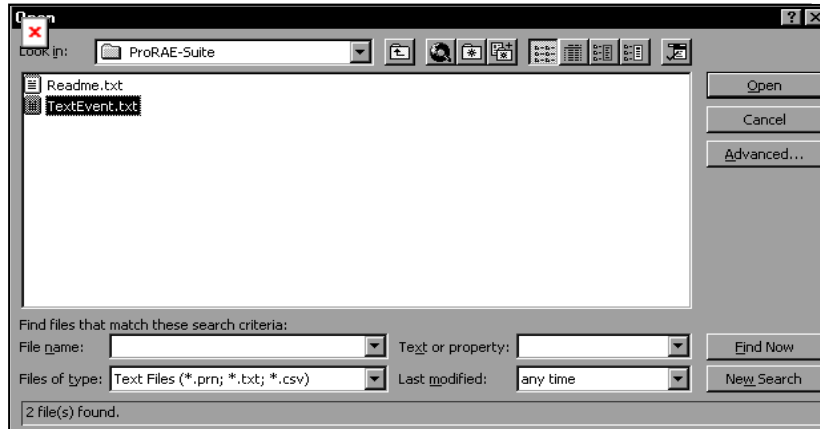

Figure C-1 Excel Window

- Click **File->Open** menu item to open the **Open** dialog box, select the folder where the file TextEvent.txt is resided, and select the **Files of type** as Text Files. Click to select the file TextEvent.txt, as shown in Figure C-2.

Figure C-2 **Open** Dialog Box

- Click **OK** button, a **Text Import Wizard** dialog box is open, as shown in Figure C-3.

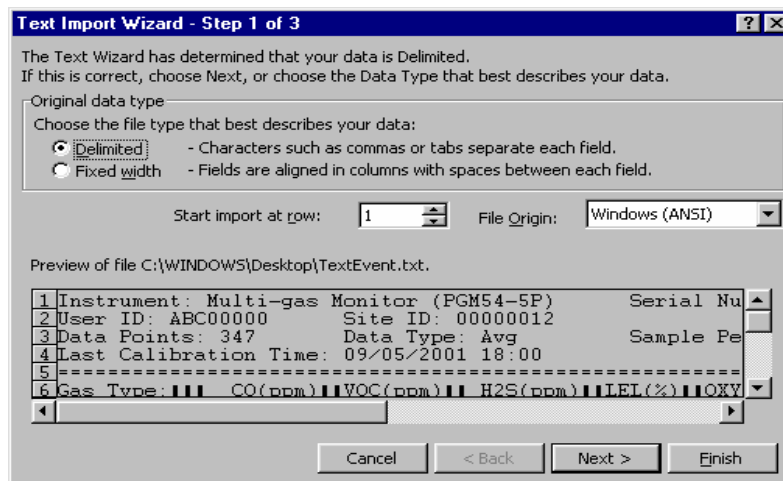

Figure C-3 **Text Import Wizard** Dialog Box

- Click **Finish** button, the dialog box disappears and the event data is loaded into the MS-Excel software, as shown in Figure C-4.

Line#	Date Time	CO(ppm) Alarm	VOC(ppm) Alarm	H2S(ppm) Alarm	LEL(%)
1	9/19/96 8:00	0.6	0.7	0.2	
2	9/19/96 8:01	4	5.6	2.4	
3	9/19/96 8:02	0.6	0.7	0.8	
4	9/19/96 8:03	0.6	5.6	3.9	
5	9/19/96 8:04	6.9	0.6	3.8	
6	9/19/96 8:05	0.2	8.6	0.8	

Figure C-4 File Text Event.txt is Open

- Click **File->Save As** menu item to save the loaded event data to a MS-Excel file. Ensure that in the **Save As** dialog box, the **Save as type** is **Microsoft Excel Workbook**.

Graphing MultiRAE IR Data in Excel®

- Open the Excel® data file that contains the data to be graphed by selecting “File” and then “Open.” Highlight the columns that contain the data points. Make sure that the header information is not highlighted.

2. Go to the “Insert” menu, and under “chart” elect “As New Sheet.”

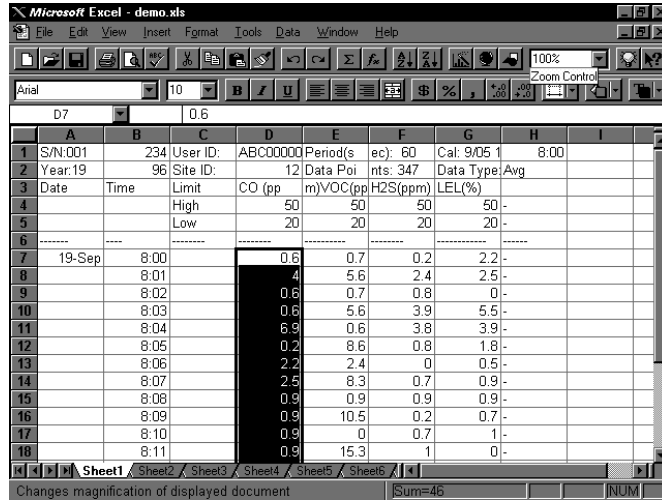

2. The first step of the ChartWizard will appear. In the “Range” area, the cells that were highlighted on the chart will be denoted.

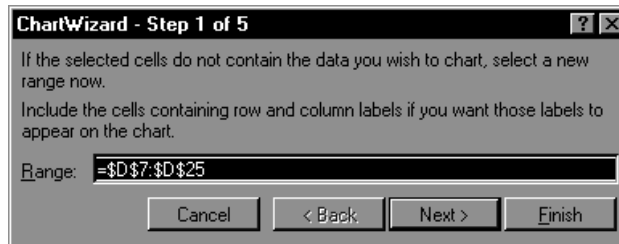

Press the “Next” button to continue.

3. The next step will show the different chart types. For this example, the “Line” chart has been selected.

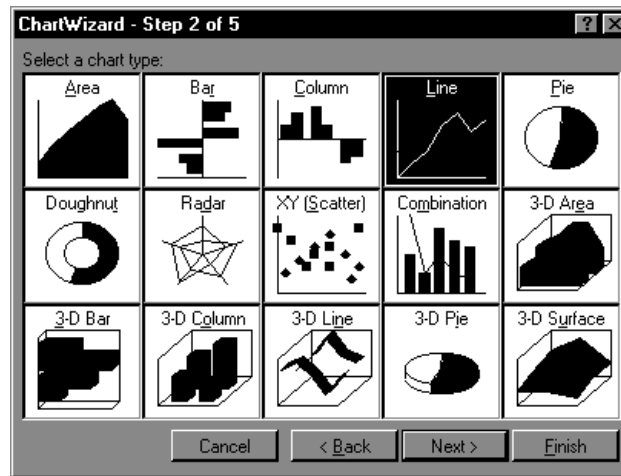

Press the “Next” button to continue.

- Step 3 of the ChartWizard give additional choices for the line chart, including data markers and gridlines. In this example, number 4 has been selected, so there will be markers and gridlines.

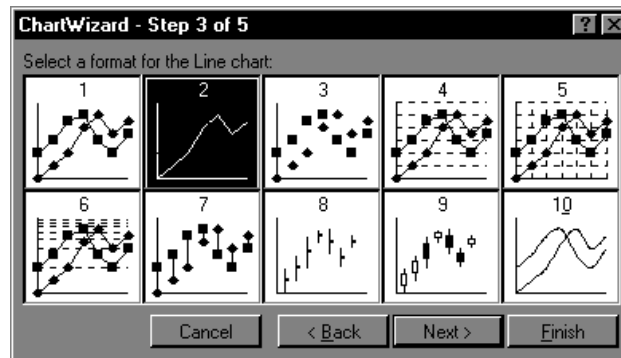

Press the “Next” button to continue.

- The next step shows a preview of the chart. This will ensure that the correct columns were chosen in the

spreadsheet that comprise the chart. Press the “Next” button to continue.

6. The final step is where the chart title and axis titles may be added. After these are added in the spaces provided, press the “Finish” button.
7. A sample of a finished chart is below. For additional information and other modifications that can be made to the Excel[®] chart, please refer to the Excel[®] instruction manual.

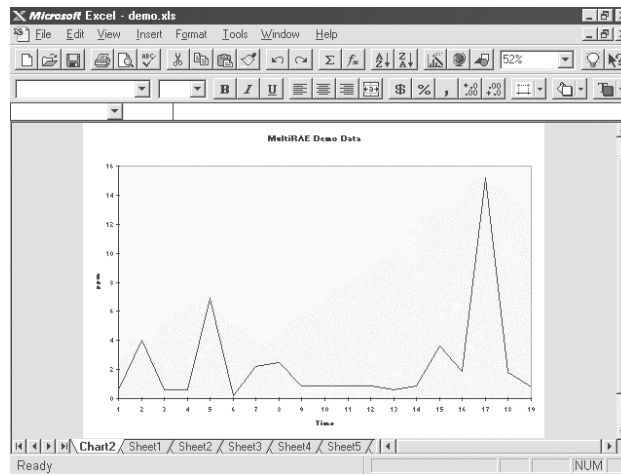

APPENDIX D. RAE SYSTEMS TECHNICAL NOTES

- π TN-102 Facts About PID Measurement
- π TN-103 External Datalogger Interface to MiniRAE PID
- π TN-104 Partial List of Ionization Potentials
- π TN-105 MiniRAE PID Battery Characteristics
- π TN-106 Correction Factors, Ionization Potentials, and Calibration Characteristics
- π TN-108 MiniRAE PLUS PGM-76 and 76IS ProRAE 76 Software Upgrade for PGM-75
- π TN-109 MiniRAE Professional PID Zero Drift
- π TN-112 MiniRAE PLUS Datalogger Data Conversion to Microsoft Excel version 5.0
- π TN-113 Calibration Procedures for ModuRAE PDM-10A
- π TN-114 ToxiRAE Sensor Specifications
- π TN-115 ToxiRAE Toxic Gas Monitor (PGM-35) at a Glance
- π TN-116 ToxiRAE Oxygen Monitor (PGM-36) at a Glance
- π TN-117 ToxiRAE Combustible Gas Monitor (PGM-37) at a Glance
- π TN-118 Use of RAE PIDs for Soil Headspace Measurements
- π TN-119 Calculation of STEL, TWA, Min., Max., and Average Values for ToxiRAE PID.
- π TN-120 Measuring Correction Factors for Volatile Compounds with MiniRAE 7 and ToxiRAE PIDs
- π TN-121 CO Sensor Cross-Sensitivity and Removal with Charcoal Filter
- π TN-122 MiniRAE Compliance with EPA Method 21
- π TN-123 Diagnostic Modes for RAE Instruments
- π TN 124 PID Lamp Characteristics
- π TN 125 Creating Custom Correction Factors and Gas Names for the ToxiRAE PID
- π TN-126 Interchangeability of Sensors in PGM-35 and PGM-50
- π TN-127 Benzene-Specific Measurements in Petroleum Hydrocarbons using the UltraRAE
- π TN-128 ToxiRAE PID Communications Problems

- π TN-130 Setting Alarm Limits for Mixtures
- π TN-131 Verifying and Fixing Gas Alarm Limits
- π TN-132 Upgrading RAE Instruments Firmware
- π TN-133 Methylene Chloride-Specific Measurements using the UltraRAE
- π TN-134 UltraRAE Bar Code Reader Patterns and Adjustments
- π TN-135 UltraRAE Firmware & Tube Data Upgrade Procedures
- π TN-136 UltraRAE Operations Tips
- π TN-137 Exiting Diagnostic Mode for ToxiRAE LEL
- π TN-138 RAE System Year 2000 Compliance
- π TN-139 UltraRAE Communication with NT
- π TN-140 Extension Tubing Volume and Delay Time
- π TN-141 MultiRAE Remote Control Functions
- π TN-142 MiniRAE 2000 Preprogrammed Compound Library
- π TN-143 Accuracy Comparisons of Gas Detection Tubes
- π TN-144 Handling LEL Sensor Poisoning
- π TN-145 Proper Care of Nickel Cadmium Battery Packs
- π TN-146 Turning On UV Lamps in a PID Monitor
- π TN-147 UltraRAE: Butadiene Specific Monitor
- π TN-148 Measurement of Phosphine (PH₃) by PID In the Food Storage industry
- π TN-149 PGM-30 UV Lamp Care
- π TN-150 Understanding the ppbRAE
- π TN-151 Electrochemical Sensor Replacement and Maintenance
- π TN-152 Effects of Operating Conditions on Oxygen Sensors
- π TN-153 TC Sensor Applications and Correction Factors
- π TN-154 SampleRAE Correction Factors
- π TN-155 2-Year Oxygen Sensor Installation and Calibration
- π TN-156 Correction Factors for Combustible Gas (LEL) Sensors
- π TN-157 Moisture Exchange Tubes for Humidity Control of Test Gases
- π TN-158 Conversion of PID Readings to Methane Equivalent Response
- π TN-159 Nerve Agent Measurements by PID
- π TN-160 Upgrading MultiRAE/QRAE Ni-Cd Battery Pack

Technical Notes are available at www.raesystems.com.
See Appendix F to order hard copies of Technical Notes.

APPENDIX E. RAE SYSTEMS APPLICATION NOTES

- π AP-200 PIDs and Aircraft Wing-tank Entry
- π AP-201 Measuring Ammonia (NH₃) with PIDs
- π AP-202 ABCs of Gases in Industry
- π AP-203 PID as a Hazmat Response Tool
- π AP-204 Pulp & Paper: Measuring Turpentine & ClO₂
- π AP-205 Measuring Heat Transfer Fluids with a PID
- π AP-206 Guide to Atmospheric Testing in a Confined Space
- π AP-207 PIDs as an Arson Investigation Tool
- π AP-208 HAZMAT User List
- π AP-209 UltraRAE User List
- π AP-210 North American RAE User List
- π AP-211 PIDs for Continuous Monitoring of VOCs
- π AP-212 PIDs for Indoor Air Quality
- π AP-213 ModuRAE PID Configuration and Applications
- π AP-214 Environmental Applications for PIDs
- π AP-215 Gas Detection in the Marine Industry
- π AP-216 Weapons of Mass Destruction
- π AP-217 Confined Spaces in the Construction Industry
- π AP-218 Lengthening the Interval Between Calibration Checks
- π AP-219 Using PIDs for 10% of LEL Decisions
- π AP-220 Using PIDs in Clan Lab Investigations
- π AP-221 PIDs for Exposure Risk in Unknown Environments
- π AP-222 CO & Natural Gas Detection for Fire Department Engine Companies
- π AP-223 ppbRAE User List
- π AP-224 Understanding the CDRAE and its Applications

Application Notes are available at www.raesystems.com.
See Appendix F to order hard copies of Application Notes.

APPENDIX F. LITERATURE REQUEST

Application and Technical Notes are available at www.raesystems.com in PDF format for printing.

For hard copies, Photocopy this page and fax to:

Attn: Literature Department

1.408.752.0724 FAX

Please send me the following information:

Name: _____

Company: _____

Mailing Address: _____

City, State, Zip: _____

Country: _____

Telephone: _____

Fax: _____

Technical Notes:
(just list TN #) _____

Application Notes
(just list AP #) _____

Comments: _____

Thank you,
RAE Systems Sales & Marketing Department

APPENDIX G. REQUEST FORM FOR RETURN MATERAIL AUTHORIZATION

**Need to send your monitor in for repair,
calibration, service or upgrading?**

For proper tracking of your equipment please obtain an **RMA
Number** before returning the monitor.

Photocopy this page and fax to Attn: Service Department:

1.408.585.3544

Electronic RMA requests can also be made through our website:
www.raesystems.com

We will return fax the RMA Number and instructions on how to ship.

We must obtain the following information in full:

Name:

Company:

Shipping

Address:

City, State, Zip

Telephone:

Fax:

Serial number:

Model:

Reason for
return:

Note: When returning an instrument for repair, please send only the monitor that needs to be worked on without any additional accessories. Only send accessories with the instrument when they are also in need of repair. This will help us get your equipment back to you in an efficient manner.

Thank you,
RAE Systems Service Department

RAE Systems Inc.
1339 Moffett Park Drive
Sunnyvale, California 94089

Main Contact Numbers

TEL: 408.752.0723

FAX: 408.752.0724

Toll Free Numbers

Instrument Sales: 877-RAE.CUSTOMer (723-2878)

Technical Service: 888.RAE.4800 (723.4800)

Tube Sales: 888.RAE.TUBE (723.8823)

E-mail:

Instrument Sales: raesales@raesystems.com

Technical Service: tech@raesystems.com

**World Wide Web site:
www.raesystems.com**