

Apollo Solar Pumps™

Installation Manual and Operating Instructions



- Install Solar Panel 2
- Inspect Shipment 3
- Prepare to Install 4-5
- Package Assembly Drawings 6
- Panel & Control Wiring 7
- Install Downhole Components 8-9
- Install Driver 10
- Startup & Maintenance 11
- Motor Brush Schedule & Replacement .. 12
- Stuffing-Box Seal Replacement 13
- Troubleshooting 14-15
- Options & Accessories 16
- Warranty & Claims 17-18



INSTALL SOLAR PANEL

NOTE: Blackhawk strongly recommends installing solar panel kit before assembling the pump. Concrete will take several days to cure. Follow manufacturer's instructions. See package assembly drawings Page 6.

A typical support pole set-up:

1. Site the mounting pole south of the wellhead to take full advantage of the sun.
2. The pole should be roughly 5 feet from the wellhead -- spaced so that a riding lawn mower cannot fit between the wellhead and the solar panel.
3. Use a 3-inch-diameter iron or galvanized steel pole.
4. A pole typically comes in 21-foot sections. Cut the pole in half, to 10½ feet.
5. Dig a 4-foot-deep post hole.
6. Pour concrete in hole and insert pole.
7. Using level, adjust the pole to vertical.
8. Allow concrete to set per package directions before attaching solar panel.
9. Attach panel to pole following manufacturer's instructions.

NOTE: For solar accessories, see Page 14



INSPECT SHIPMENT

Examine shipped materials. Report and document any damage immediately, before installation. Keep drive motor and components in original shipping cartons until needed.

TOOLS REQUIRED



You will need (from left): Two pipe wrenches, adjustable wrench, channel lock pliers, small vice-grip pliers, ratchet wrench with 1/2-in. socket, three open-end wrenches (1/2-in., 9/16-in. and 11/16-in.), hacksaw. Also: (top): Flat-blade screwdriver, electric tape, Teflon-type tape, tape measure, silicone spray lubricant, dark-ink marker.

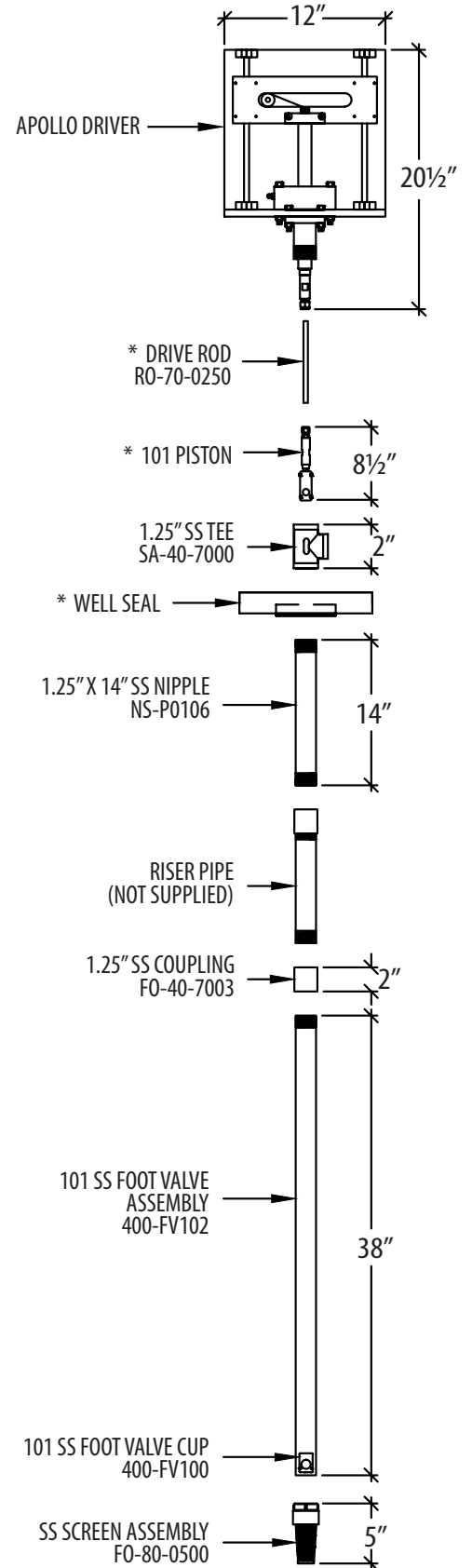

* AVAILABLE BY ORDER



PREPARE TO INSTALL



A Assess well condition

A new well should be free of drill cuttings and pipe-casing debris. Check well-casing's inside diameter to make sure it is not smaller than the pump components.

B Lay out downhole components

1. Remove from packaging: Downhole assembly, well seal, drive piston, discharge tee, pipe nipple, connectors, coiled HDPE riser pipe.
2. Carefully uncoil fiberglass drive rod.
CAUTION: Rod coil is under tension. Uncoil in open area. Wear safety glasses and gloves.
3. Connect piston to drive rod. Rod should come with a nut and ferrule installed on one end. Strenuously tighten the nut to the piston assembly. Ferrule must be crimped or mushroomed into rod.
4. Lay out rod with attached piston, well seal, discharge tee, nipple, riser and other parts (left photo).

Assemble piston to drive rod

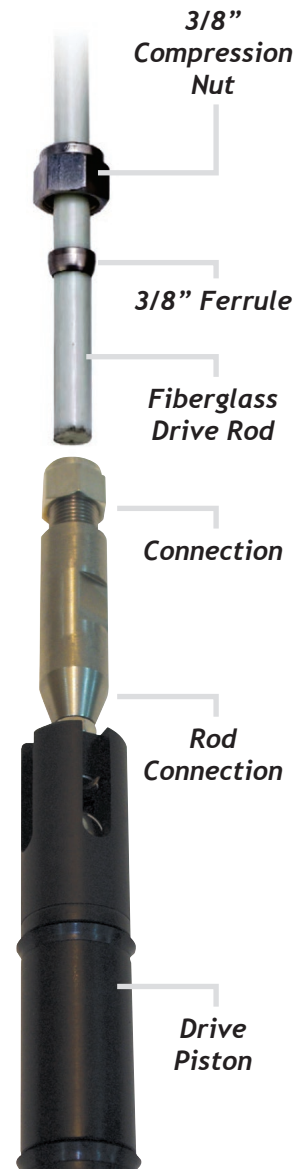

Discharge tee, well seal, pipe nipple, drive rod.

Lay out piston, drive rod, well seal and discharge tee. At left are foot-valve assembly and coiled HDPE riser pipe.

PREPARE TO INSTALL

C Determine installation depth – Critical

You must be certain of the well depth and static water level in the well to ensure accurate bottom settings for the pump intake. Improper settings can impede operations, damage the pump and invalidate the warranty. To determine depths:

1. Feed piston and rod into well casing (see photo). Stop when piston reaches bottom.
2. Determine desired depth of pump above well bottom. Note that silt and sediment near well bottom can clog intake. Pump's end point should be several feet above well bottom.
3. Pull rod up the desired length; mark rod.



Fit rod into well casing. Stop when piston reaches bottom.

D Solar power supply

Apollo's 3/8 hp linear-rod motor runs on 24-volt solar power. Use 8 amp fuse only. Connecting the motor to electric power is specifically not recommended and can invalidate warranty.

SOLAR PACKAGE & DRIVER ASSEMBLY

APOLLO SOLAR PACKAGE

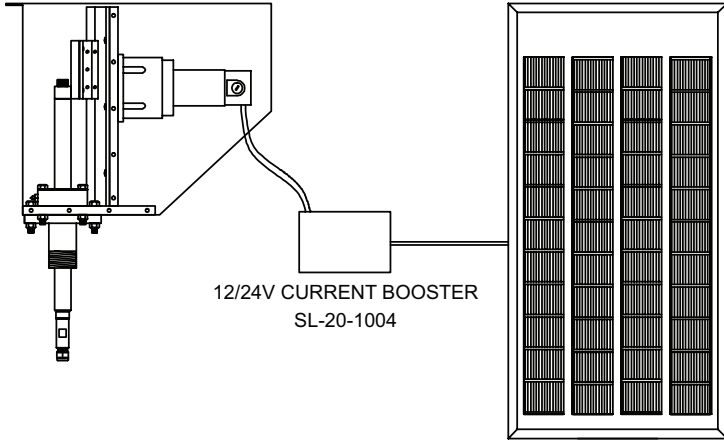

- 30' MC4 CABLE EXTENSION
SL-20-1001
- 50' MC4 CABLE EXTENSION
SL-20-1002
- MC4 CONNECTOR KEY
SL-20-1003

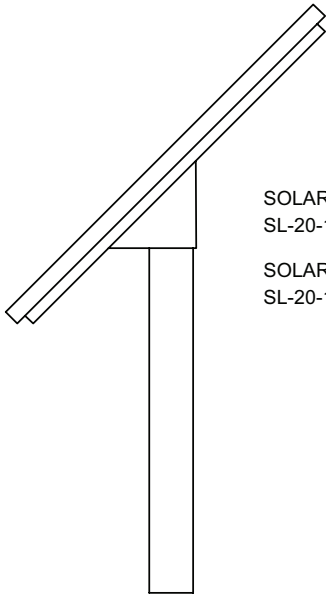

APOLLO DRIVER ASSEMBLY

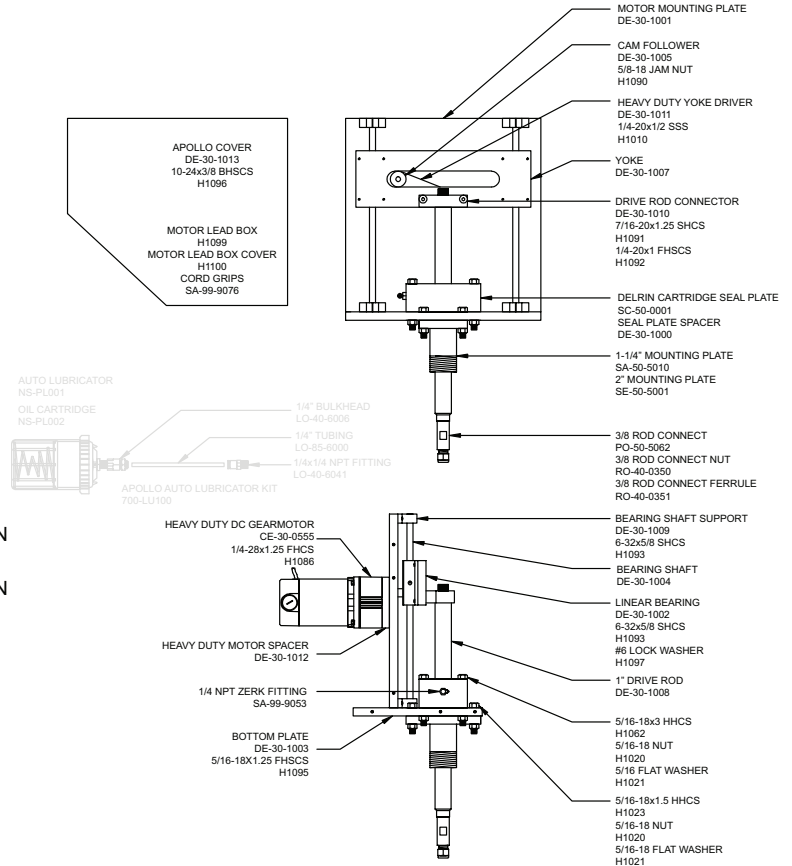

SEAL PLATE: 1-INCH ROD

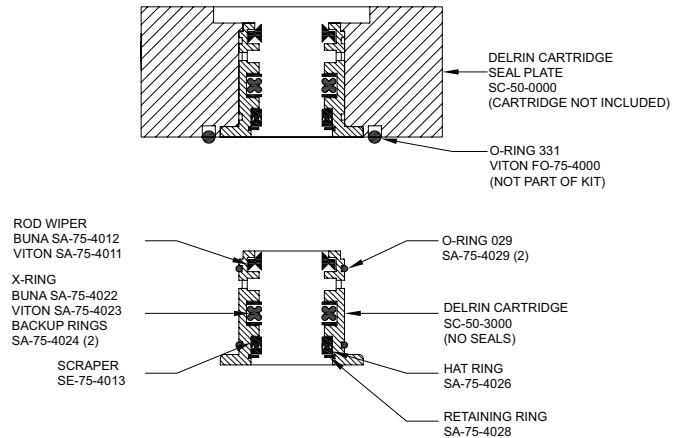

Seals available in both Buna and Viton



PANEL & CONTROL WIRING

SOLAR PANEL WIRING

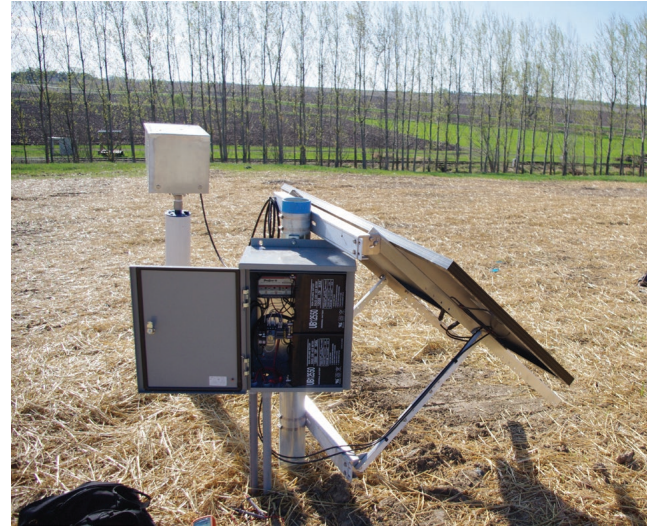
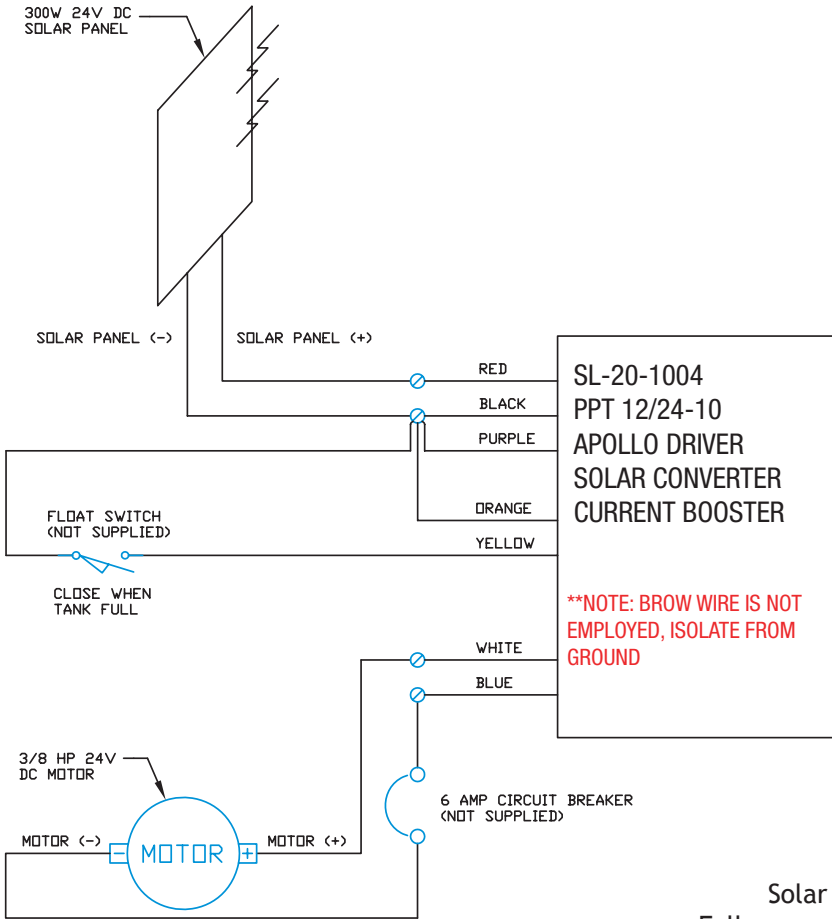

Apollo driver, control box (with batteries) and panel

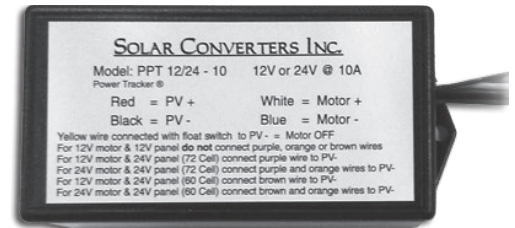

Solar Controller:
Follow manufacturer's
installation instructions



Converter and breaker mounted behind panel

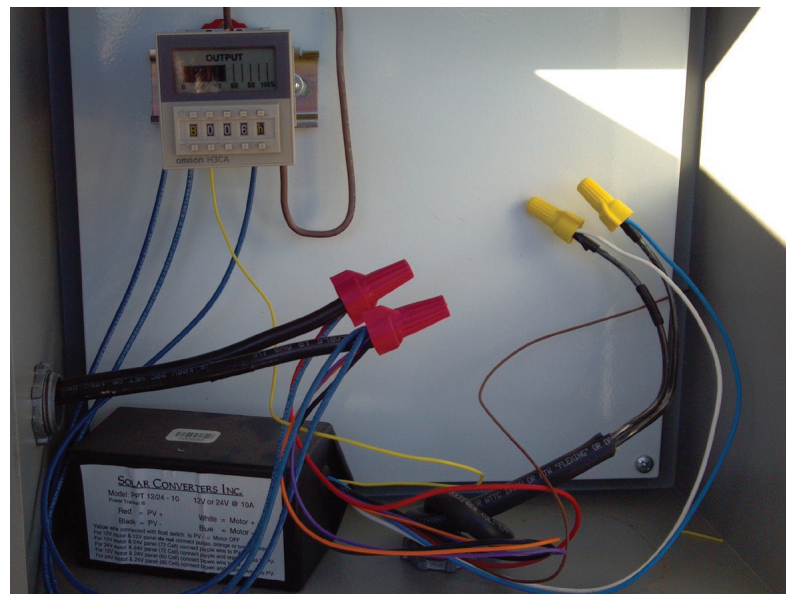

Converter with timer

INSTALL DOWNHOLE COMPONENTS

1. Lay out downhole components and determine installation depth (see page 4)
2. Determine length of riser pipe.
(See drawing at right.)
 - a) Important: Measure the combined length of foot valve and strainer screen, including their fittings. Then add length of pipe nipple, plus desired distance from well seal to well bottom.
 - b) Subtract that combined number from well depth.
3. Assemble downhole components (see Page 2 drawing).
 - a) Apply Teflon tape or equivalent to threads during assembly.
 - b) Insert pipe nipple through bottom of well seal.
 - c) Insert discharge tee through top of seal. (See Page 9 photo)
4. Open well; Prepare wellhead by removing all debris, caps or other enclosures. Casing must be at proper height to allow well installation and servicing, generally no higher than 4 feet (1.2 meters).
5. Install downhole assembly, foot-valve assembly first, into well casing. (See Page 9 photo).

How to Measure Riser-Pipe Lengths

- Add together length of nipple (N), length of foot valve assembly with strainer (F) and desired distance from bottom of pump to bottom of well (D).
- Subtract that number from the distance between well seal and well bottom (W).

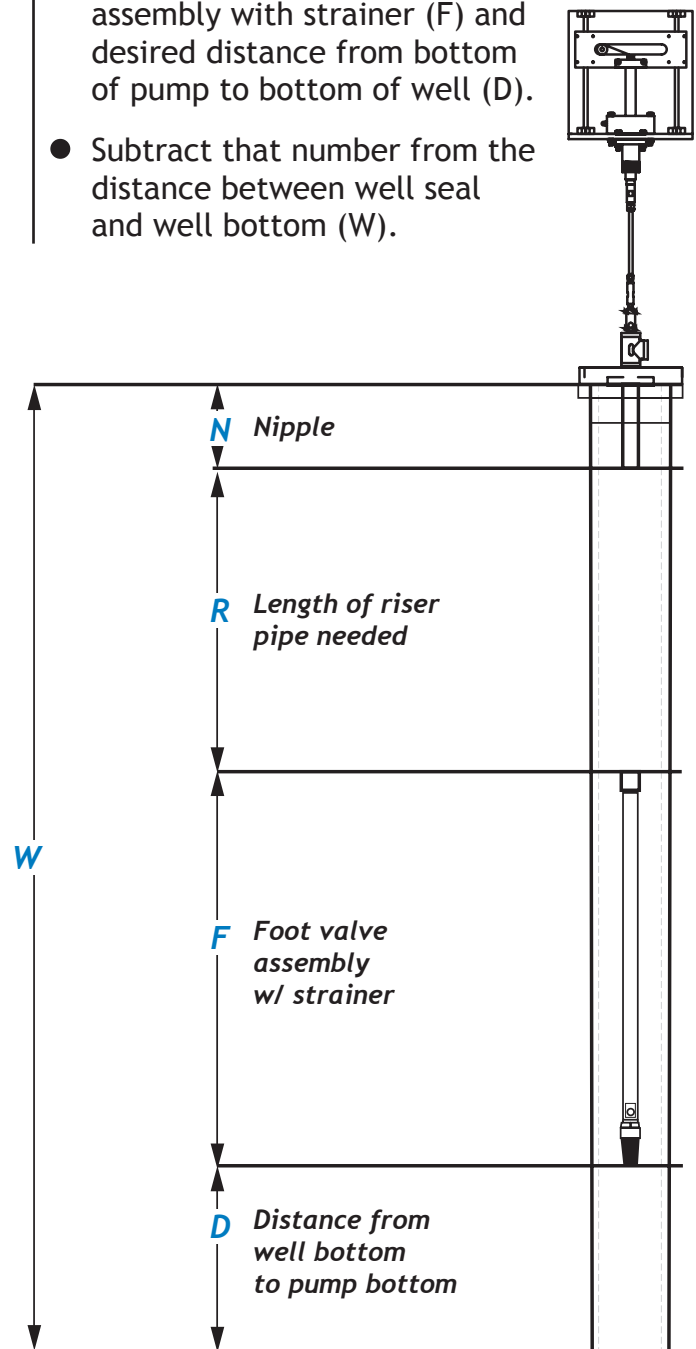

INSTALL DOWNHOLE COMPONENTS



Feed downhole assembly, foot-valve first, into well casing.

6. Piston now should be connected to fiberglass drive rod. If not, see Page 4. Be careful. If still coiled, rod is under tension and can be dangerous if not properly handled.

7. Insert piston and drive rod into riser assembly. Gradually feed rod through the riser pipe toward the foot-valve assembly.

(NOTE: If riser pipe assembly is sufficiently larger than piston, the piston and rod can be installed through the discharge tee at surface.)

8. Firmly grip the drive rod. Pump by hand to fill the riser with liquid. This step ensures the piston is correctly positioned in the foot-valve assembly.

9. Make certain the piston has bottomed out in the foot valve. Mark the rod at the top of the tee.

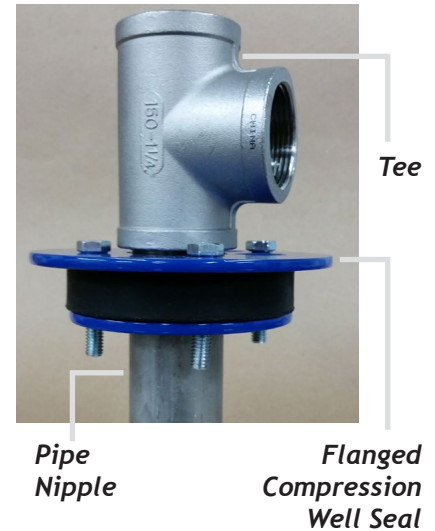

Pipe Nipple

Flanged Compression Well Seal

Well seals are either compression or steel-flanged, with or without gas pipe. For well-seal options, see Page 14.

Rod Attaches to Drive Motor

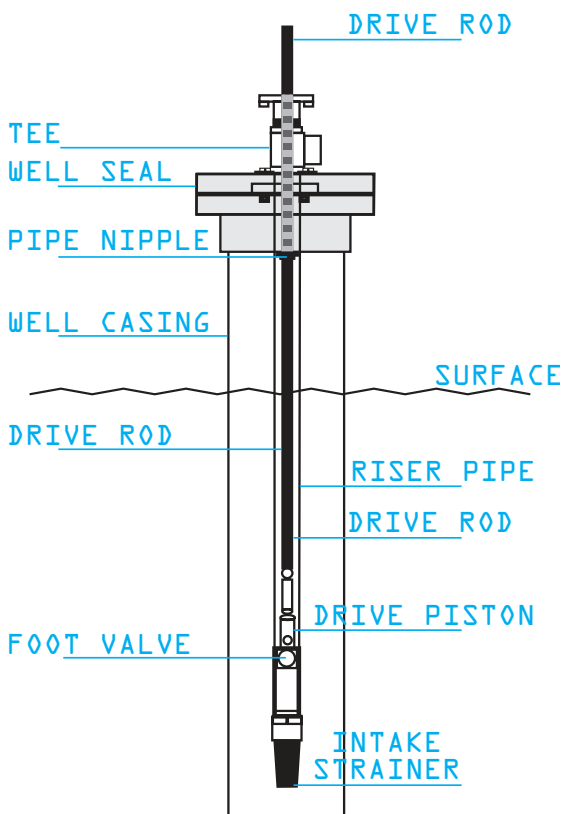

Straight Flanged

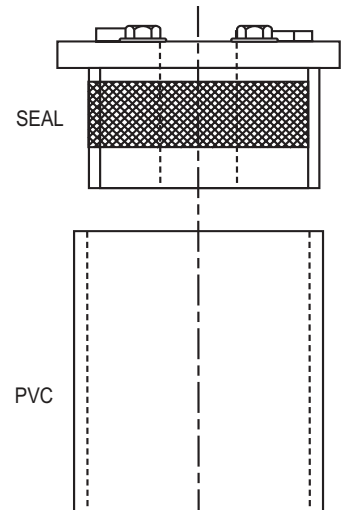

Flanged gas well

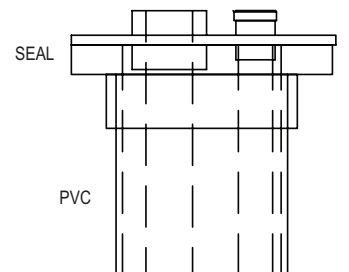

INSTALL DRIVER

1. Pull up the drive rod; note mark on tee (Page 9, Step 9)
2. Mark the rod again, 20 inches below first mark. See drawing below.
3. If the drive rod cannot be removed from the riser, lightly clamp vice-grip pliers to the rod to prevent it from slipping back into the riser.
4. With hacksaw, cut rod at the lower mark.
Cut all the way around rod to prevent splintering.
5. Install nut and ferrule on rod, if necessary. Insert rod into driver coupling. Strenuously tighten nut to coupling. The ferrule must be crimped or mushroomed into the rod.
Reconnect rod to drive motor.
6. Before attaching driver, see System Startup (Page 11)

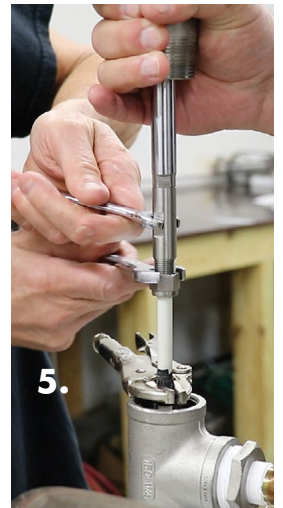
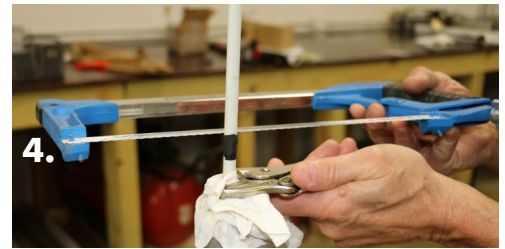
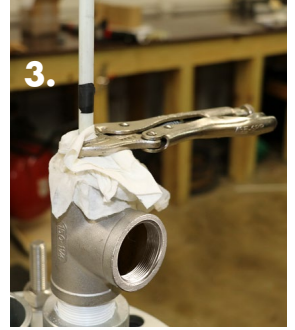

Rod-cutting Instructions

Piston must bottom out in foot valve (Fig. A).
Mark rod at top of tee with dry marker (Fig. B).
Cut rod 20 inches below mark (Fig. C).
The cut rod should extend above tee (Fig. D).

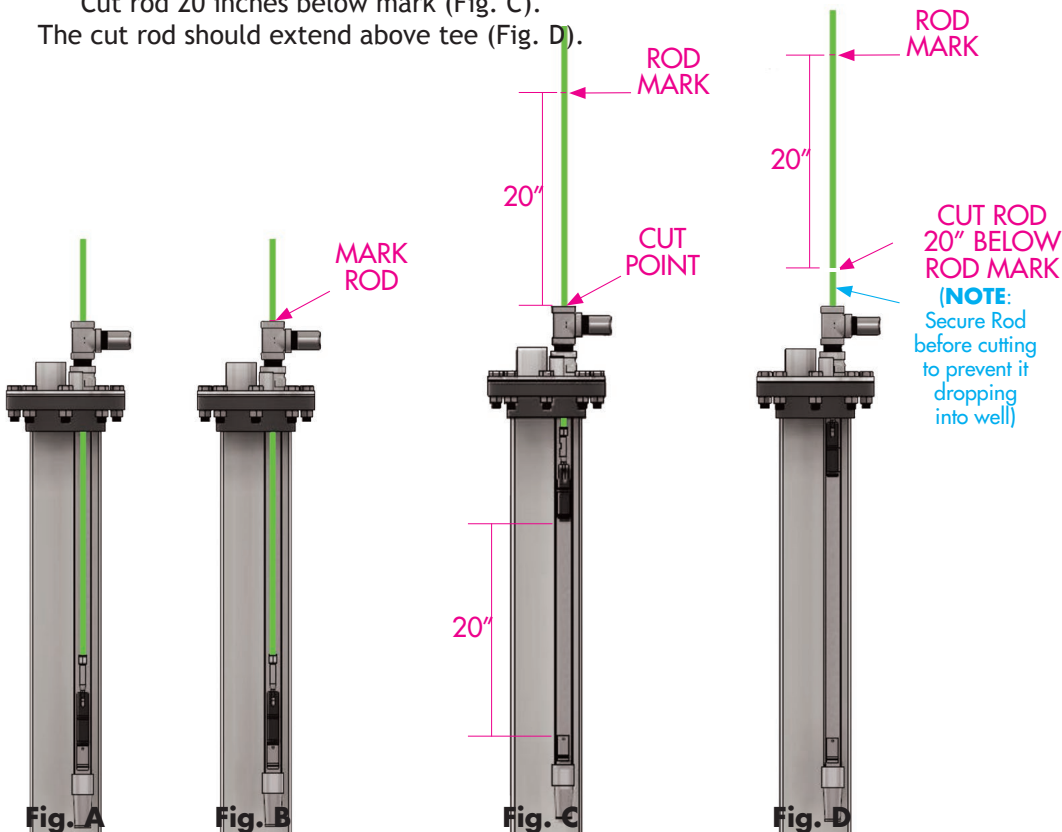

STARTUP & MAINTENANCE

SYSTEM START UP

1. Attach temporary hose to discharge tee.
2. Connect power supply.
3. Operate pump until liquid runs completely clear of sediment and silt.
4. Turn off power supply and disconnect hose. Complete final discharge connections.

IMPORTANT: Never operate pump with discharge valve closed or discharge pipe clogged. The stuffing box seal can fail and require replacement.

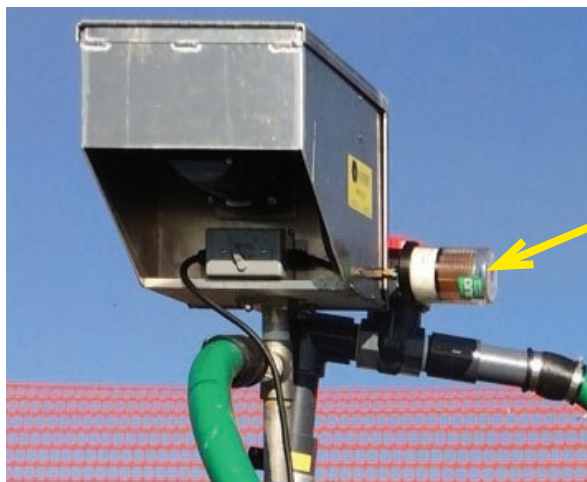

Continuous Oiler

Continuous rod lubrication extends rod life

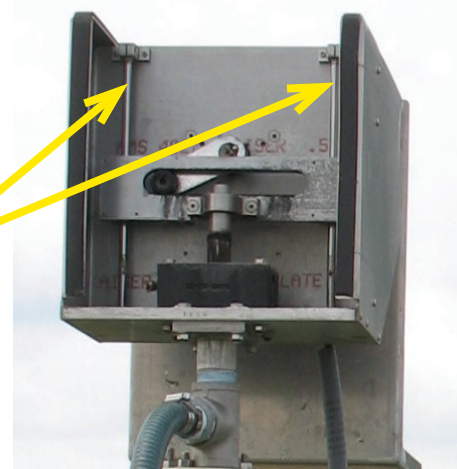

Lubricate Monthly

Lightly oil rails above rod bearings

REQUIRED MAINTENANCE

1. Check pump periodically for pressure, draw down, cycle rate and performance.
2. Visually inspect pump. Make sure polished metal drive rod is clean and free of dirt, stains and sticky residue.
3. Check liquid discharge
4. Lubrication REQUIRED to avoid pump-driver failure
 - Lightly lubricate rod bearings monthly with 10 PAO air-line oil. Do not over-oil.
 - Attach continuous oiler to seal plate - strongly recommended. Polished drive rod must be clean and lubricated.
5. Replace motor brushes annually or earlier if needed. Follow manufacturer's instructions

Apollo DC Motor Schedule & Brush Replacement



Remove cover screws with Allen wrench

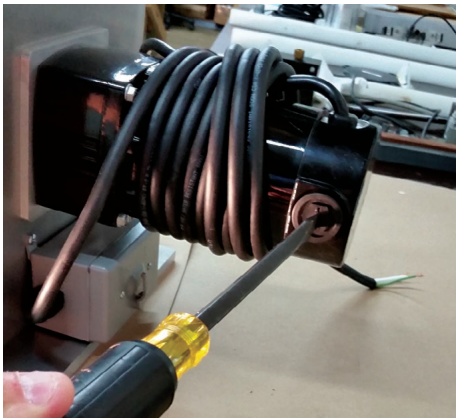

Remove motor end caps with blade screwdriver

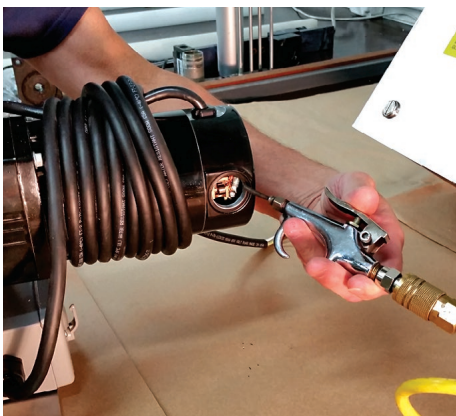

Blow out dust from motor cavity

Recommended maintenance schedule for the Apollo Solar Piston Pump™ includes inspection of the brushes in the Bodine DC motor.

Inspect every six (6) months in standard usage, or sooner in continuous or heavy-duty operation.

Motor brushes should be replaced before length reaches 3/8-inch (.375 inch) or less.

Failure to replace brushes will damage the motor and invalidate the pump warranty.

NOTE: When inspecting brushes, clean dust from enclosure with compressed air.

Tools needed to access the Bodine DC motor inside the Apollo hood are:

- 1/8-inch Allen wrench
- 1/2-inch flat-blade screwdriver

For instructions on inspecting and replacing brushes, refer to Bodine manual included with pump delivery.

Online: www.bodine-electric.com/Asp/Literature.asp#Maintenance_Instructions

REMOVE APOLLO HOOD

1. With 1/8-inch Allen wrench, remove 12 screws; six on each side of hood.
2. Lift hood from plate and set aside

OPEN MOTOR ENCLOSURE

1. Use 1/2-inch flathead screwdriver to remove two plastic screws at motor end cap.
NOTE: Using smaller screwdriver may damage plastic screws.
2. Clean motor cavity with compressed air/keyboard duster.
3. Refer to Bodine manual for detailed instructions.

Instructions for Inspecting and Replacing Brushes

in Bodine Type 33A, 42A, and 32A (PMDC) Motors or Gearmotors



BODINE
ELECTRIC
COMPANY

www.bodine-electric.com

QUALITY
IN
MOTION

Brush replacement manual cover



HOW TO REPLACE STUFFING-BOX SEALS

- 1) Push out cartridge from seal block.
 - 2) Remove two outside O-rings.
 - 3) Remove rod wiper. Use pick tool to snag seal and pull from groove.
 - 4) Flip cartridge over. Use small, thin-blade screwdriver to remove split (retaining) ring.
- For V-Stack™ cartridge only:**
- 5) With same screwdriver, remove Variseals and Hat Rings.
Go to Step 7
- For Hat Ring® cartridge only:**
- 5) With same screwdriver, remove Variseal and Hat Ring.
 - 6) Using dental-style pick tool, remove X-rings, backup rings.
Go to Step 7
- 7) Soak cartridge in paint thinner 30 minutes.
 - 8) Clean grooves with fine wire brush; be careful to avoid marring.
 - 9) Soak in green or orange grease cutter 30 minutes.
 - 10) Rinse thoroughly with water.
 - 11) If cartridge not fully clean, repeat steps 8-10. Dry.
 - 12) Install new seals in inverse order from above - refer to cartridge drawing.
 - 13) Push clean cartridge back into block.



NOTE: A Blackhawk technician will replace seals and clean cartridges in our factory at low cost with quick turnaround, returned good as new: 800-469-4887, dparison@blackhawkco.com.



Replace clean cartridge

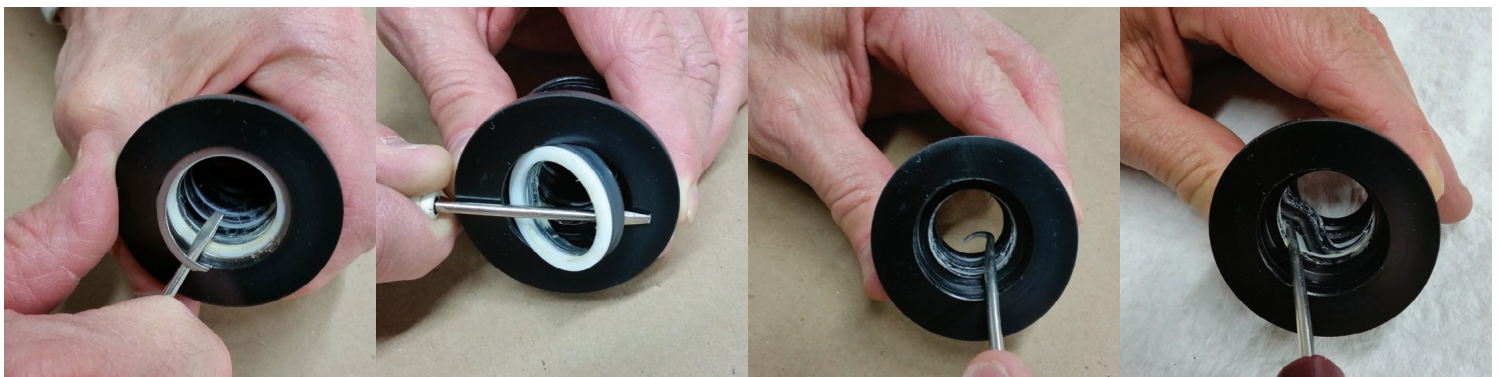

Remove split ring

Remove Variseal(s)

Pick tool

Pull X-rings

TROUBLESHOOTING

OBSERVATION

CAUSE

SOLUTION

- Pump not operating

- No power.
- Restricted liquid discharge.
- Piston drive disconnected.

- Check to see that the power supply is on, and that all connections are sound
- Open discharge valve.

- Pump driver operating (cycling), but not pumping liquid.

- Restricted liquid discharge.
- Piston drive disconnected.

- Check for closed valve, clogged discharge or any other obstruction.
- Remove obstruction and restart pump.
- Make sure drive rod is connected.
- If separated at compression fitting, a replacement drive rod ferrule will be required. (Ferrules cannot be recrimped).

- Driver cycles properly but pump not pumping liquid.

- Plugged bottom intake.

- Disconnect liquid discharge hose/pipe from pump's discharge tee. Hold latex glove (or other inflatable object) over discharge tee mouth. Seal with a tight grip. Allow pump to operate. If no discharge, raise pump strainer from mud.

- Glove does not inflate or deflate as pump cycles.

- Downhole drive rod may have been cut incorrectly.
- Riser pipe string may have a leak.
- Drive rod disconnected from drive motor.
- Check balls do not seal.

- Remove and re-cut or adjust rod length as per installation instructions.
- Check pipe connections and check for cracks or leaks. Repair or replace compromised pipe or fittings.
- Pull piston and inspect check balls.

- Glove inflates more and more as pump cycles.

- No liquid at pump intake (downhole) to pump.

- Check to make sure that there is liquid to pump.



TROUBLESHOOTING

OBSERVATION

- Glove inflates on up stroke and deflates on down stroke, and does not inflate more and more with every stroke.

- Foot valve assembly/pipe string not water tight.

- Water stays in riser pipe (and drive rod and drive piston have been deemed OK).

- Drive rod/drive piston assembly tough to remove from foot valve assembly riser pipe. Suction pull back.

- Pump driver moving erratically when operating.

CAUSE

- Plugged intake

- With drive rod and drive piston out of riser pipe, fill riser pipe with water. Water drains out quickly.

- Foot valve assembly/pump intake clogged.

- Pump intake may be clogged.

- Loose connections.

- Downhole drive rod length incorrect.

SOLUTION

- Raise pump

- Remove riser pipe and foot valve assembly and inspect, replace, and/or repair.

- Remove riser pipe and foot valve assembly and inspect. Clean piston and foot valve. Raise pump out of mud.

- Follow directions for clogged intake foot valve.

- Check all connections to be sure they are tight.

- Check rod length and adjust as per installation instructions.

OPTIONS & ACCESSORIES

ROD OILER



CHARGE CONTROL



ON-OFF TIMER



FLOW METER



DISCHARGE ASSEMBLY

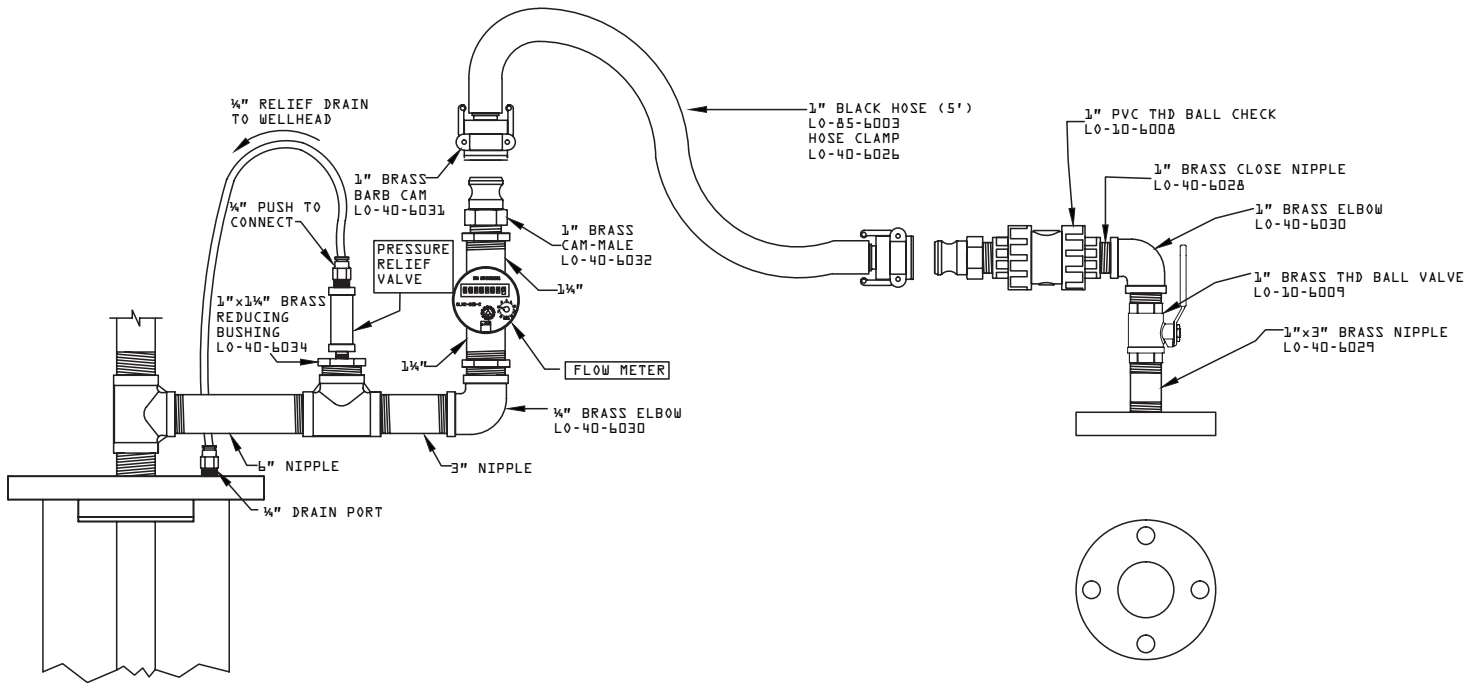

WELL SEALS

*Other sizes available



4" Steel Flanged

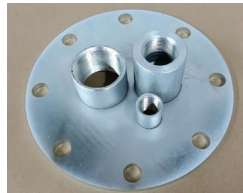

6" Steel Flanged

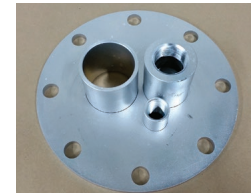

6" w/ Gas Head



8" Steel Flanged

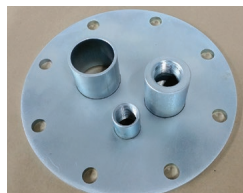

8" w/ Gas Head

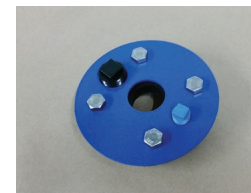

Compression Seal-top



WARRANTY, TERMS, & CONDITIONS

Limited Warranty

Pumps (excluding seals) manufactured by Blackhawk Technology Company (Blackhawk) are warranted, to the original user only, to be free of defects in material and workmanship for one year from the date of invoice.

Terms and Conditions

Final delivery date will be determined at time of order. All prices are in U.S. dollars, F.O.B. Glen Ellyn, IL USA. A copy of Buyers Purchase Order is required at time of order. "Delivery time on all specials will be determined after receipt of order." Terms are Net 30 days. Total quoted price does not include freight charges. Freight will be prepaid and added to Blackhawk Technology's final invoice to buyer. A service charge of 1.5% per month will be applied to all past-due invoices. Pricing is valid for 30 days. Notwithstanding anything contained herein to the contrary, the parties agree that the terms and conditions set forth in the limited warranty of Blackhawk Technology Company shall supersede any of the terms and conditions otherwise set forth.

Blackhawk's liability under this warranty shall be limited to repairing or replacing at Blackhawk's option, without charge, F.O.B. Blackhawk's factory, any product that Blackhawk manufactures. Blackhawk will not be liable for any costs of removal, installation, transportation or any other changes that arise in connection with a warranty claim. Products that are sold but not manufactured by Blackhawk are subject to the warranty provided by manufacturer of said products and not by Blackhawk's warranty. Blackhawk will not be liable for damage or wear to said products by abnormal operating conditions, accident, abuse, misuse, unauthorized alteration or repair, or if the product was not installed in accordance with Blackhawk's printed installation and operating instructions.

To obtain service under this warranty, the defective product must be returned to Blackhawk together with proof of purchase and installation date, failure date, and supporting installation data. Unless otherwise provided, contact will be made to Blackhawk for instructions prior to return of defective product. Any defective product to be returned to Blackhawk must be sent freight prepaid; documentation supporting the warranty claim/or a return Material Authorization must be included if so instructed.

Blackhawk will not be liable for any incidental or consequential damages, losses, or expenses arising from

installation, use, or any other causes. There are not expressed or implied warranties, including mechanical ability of fitness for a particular purpose, that extend beyond those warranties described or referred to above.

Some jurisdictions do not allow the exclusion or limitation of incidental or consequential damages, and some jurisdictions do allow limitations on how long implied warranties may last. Therefore, the above limitations or exclusions may not apply to you. This warranty gives you specific legal rights and you may also have other rights that vary from jurisdiction to jurisdiction.

In the event of perceived failure of a Blackhawk Technology Company product, please follow this warranty claim procedure:

1. Verify that the problem is due to the suspected product and not another part of the system. You may call Blackhawk technical support for advanced troubleshooting assistance.
2. If you confirm that a Blackhawk product is defective, detail in writing the exact nature of the failure.
3. The product must be accompanied by notation of a dated proof of purchase, installation date, failure date and supporting installation data that are satisfactory to Blackhawk.
4. Return the product, the written description of the failure, and supporting notation to Blackhawk's home office, 21W211 Hill Avenue, Glen Ellyn, IL 60137, along with your address and a daytime phone number. Purchaser must prepay all delivery costs or shipping charges, as well as any other charges encountered in shipping any defective Blackhawk product under this warranty policy. No shipment will be accepted collect.
5. Any return from Blackhawk will be sent via Blackhawk's preferred shipping agent. Special shipping arrangements are available at the customer's expense.

